

De la part de
FAN DE SCOOTER

TOUS ACCESSOIRES
POUR *Vespa*

ARPEL
ACCESSOIRES

188 bis, boulevard PEREIRE - PARIS 17^e
TÉLÉPHONES : ETOILE 12-36 ET GALVANI 79-64

De la part de
FAN DE SCOOTER

TOUS ACCESSOIRES
POUR *Vespa*

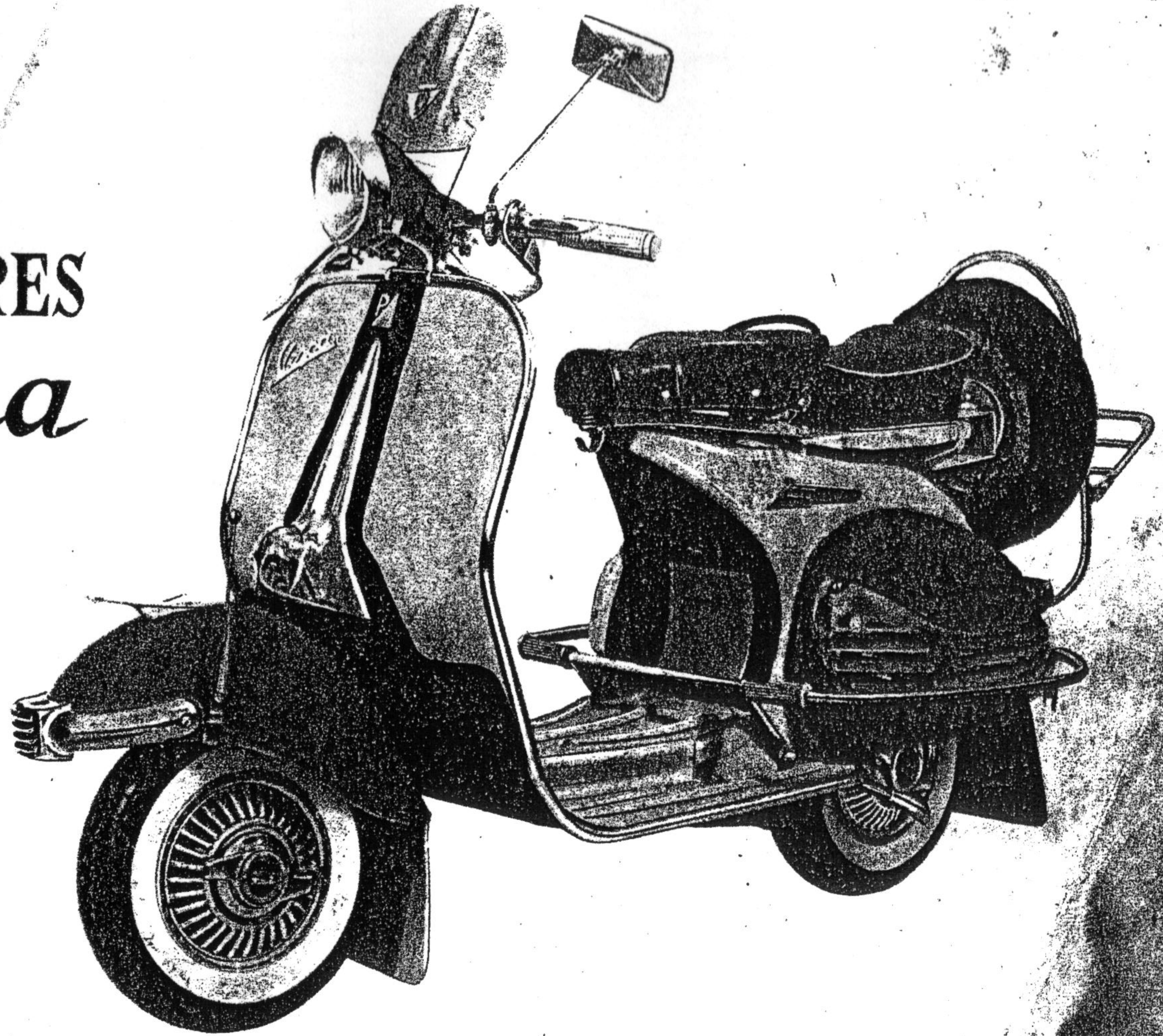

ARPEL
ACCESSOIRES

... griffe de l'élégance

188 bis, boulevard PEREIRE - PARIS 17
TÉLÉPHONES : ETOILE 12-36 ET GALVANI 79-64

De la part de
FAN DE SCOOTER



Sabots d'Ailes

907 - Sabots d'ailes courts laiton chromé

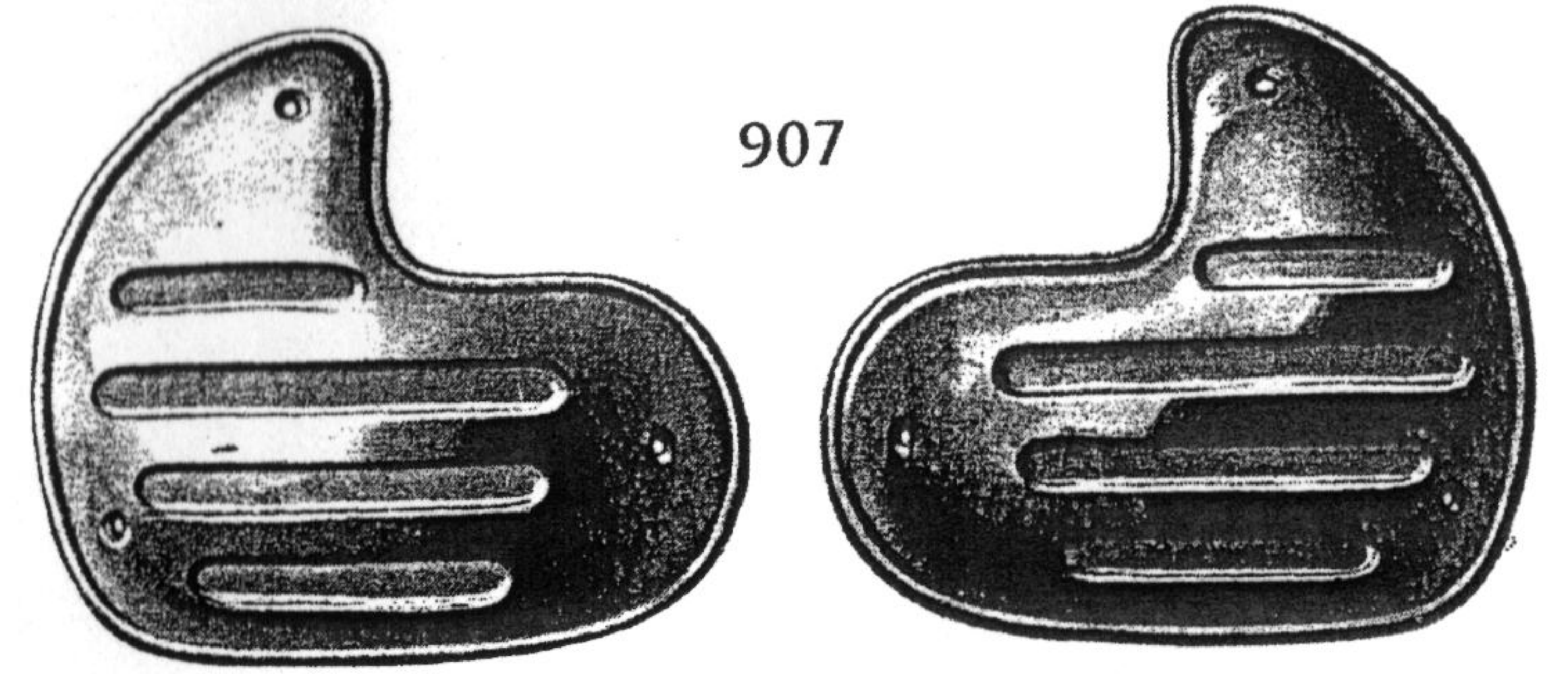

750 - *Jeux d'Ailettes
décoratives*

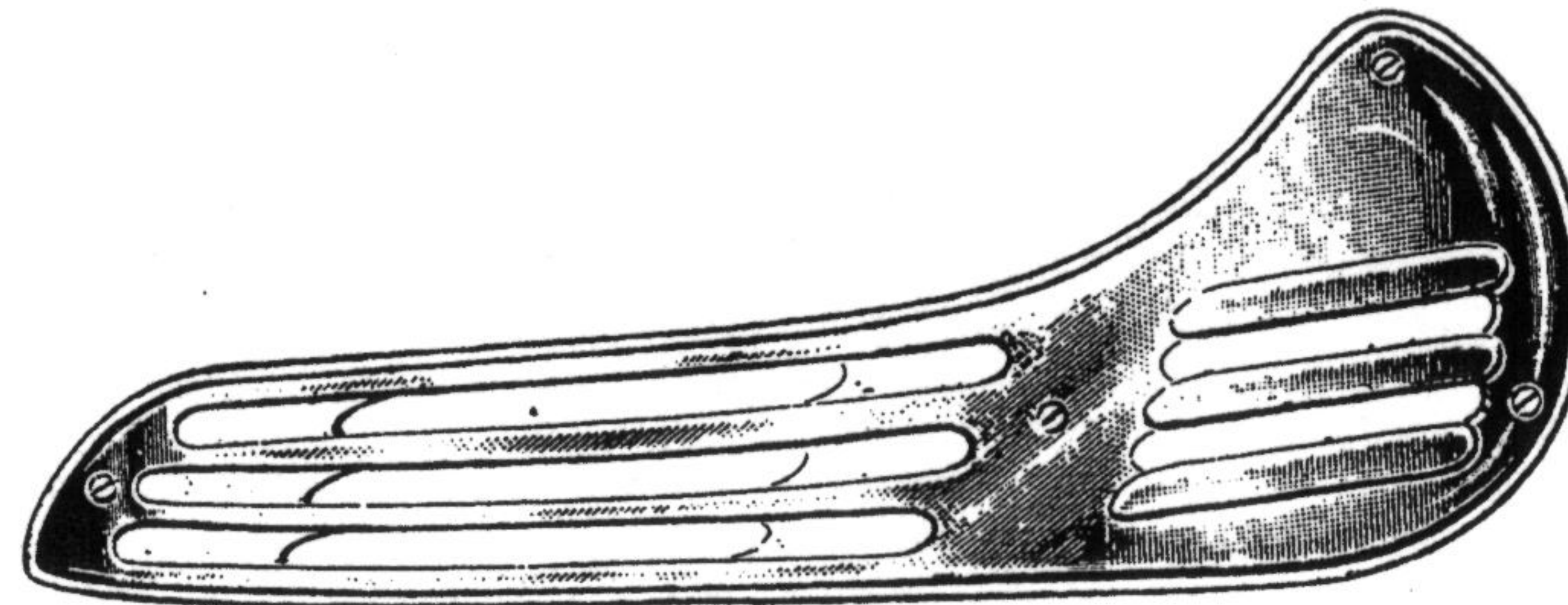

842

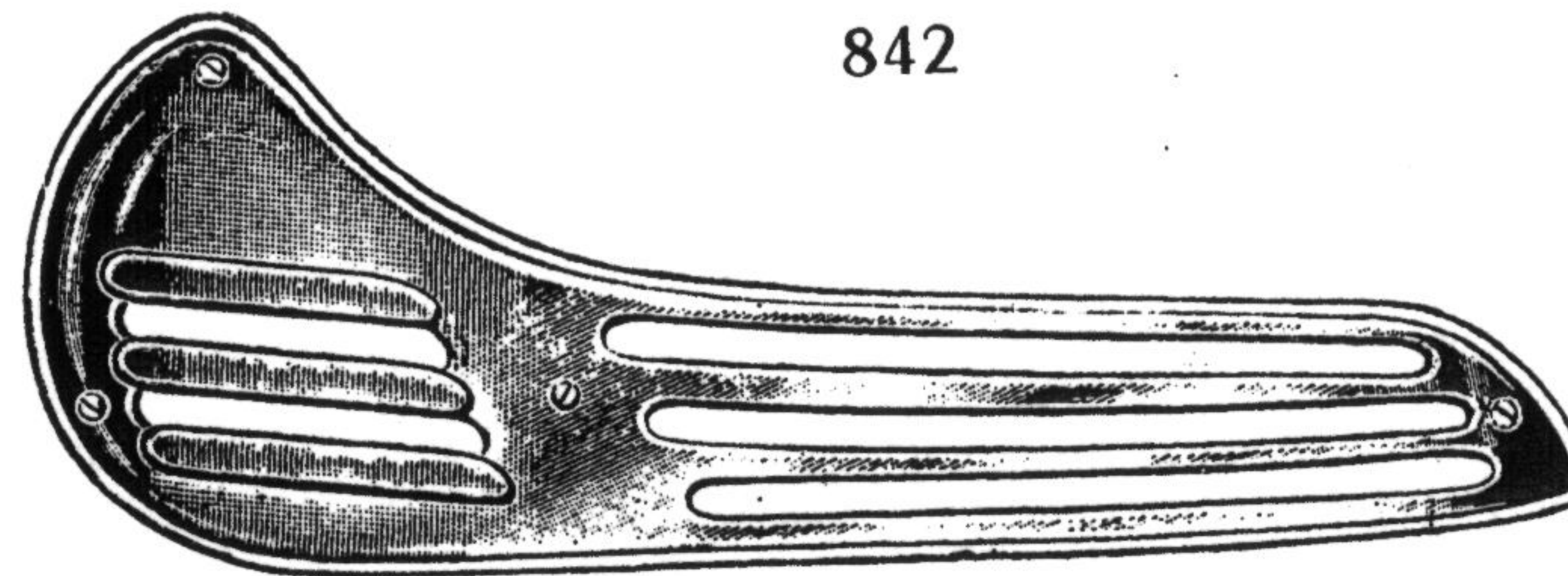

842 - Sabots d'ailes longs
laiton chromé

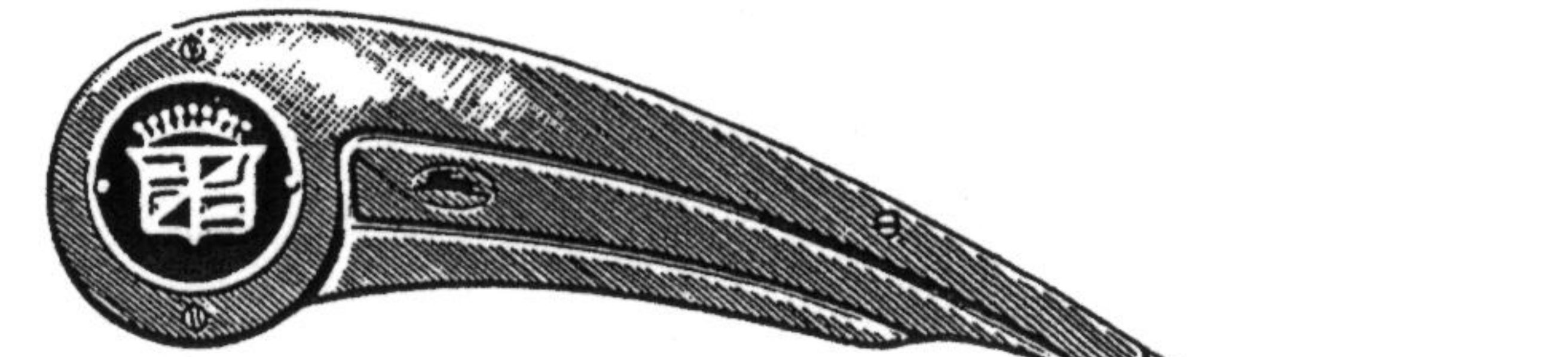

1037

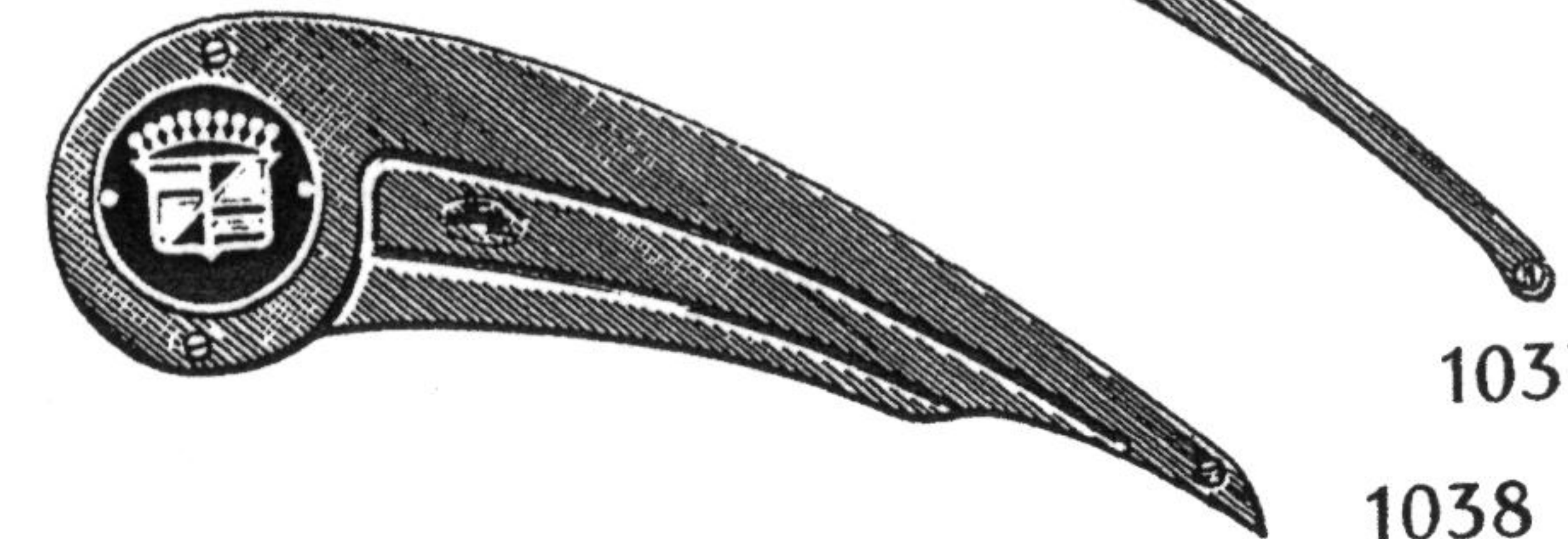

1038

Flammes décoratives

1037 - Grand modèle laiton chromé
1038 - Petit modèle laiton chromé

841

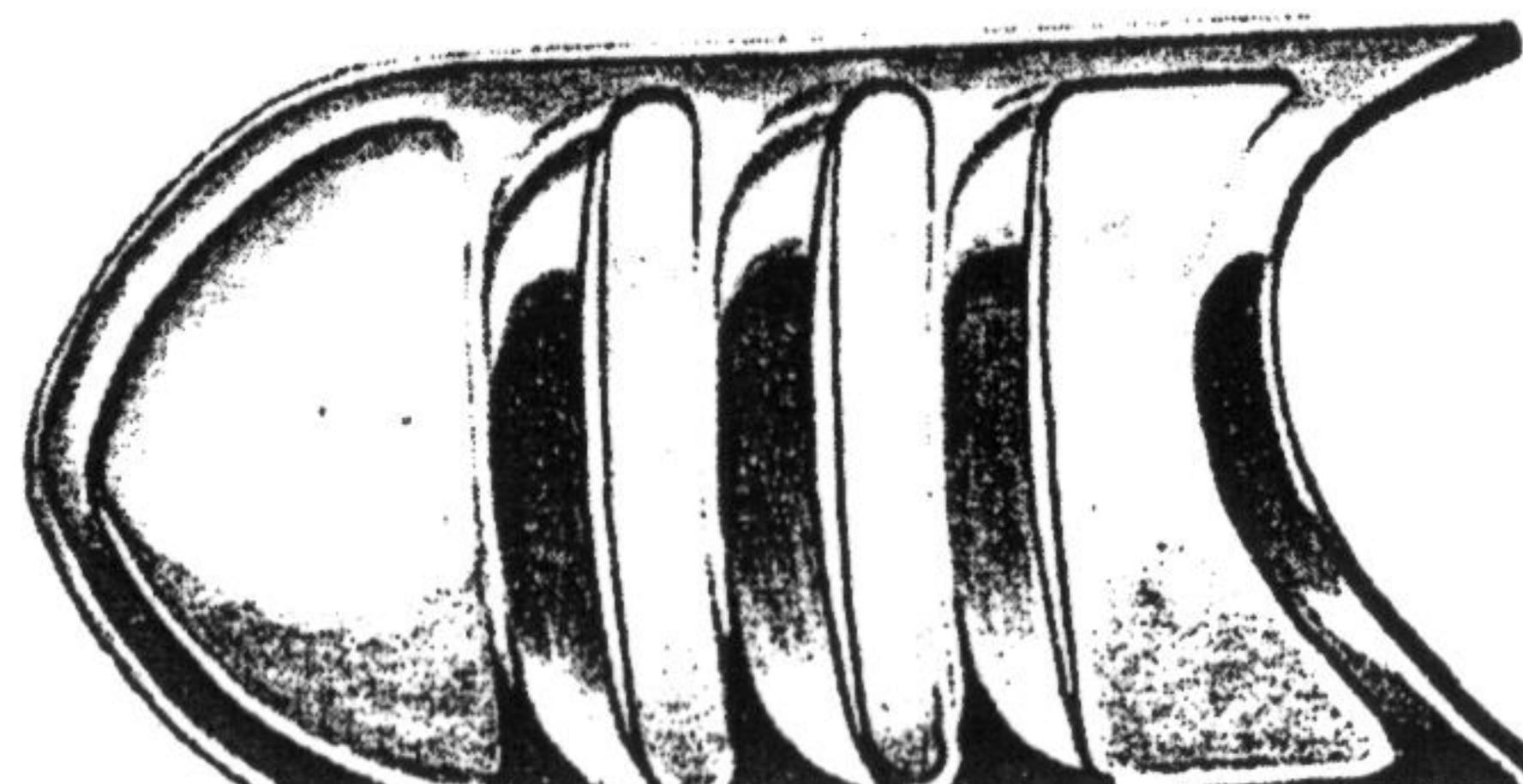
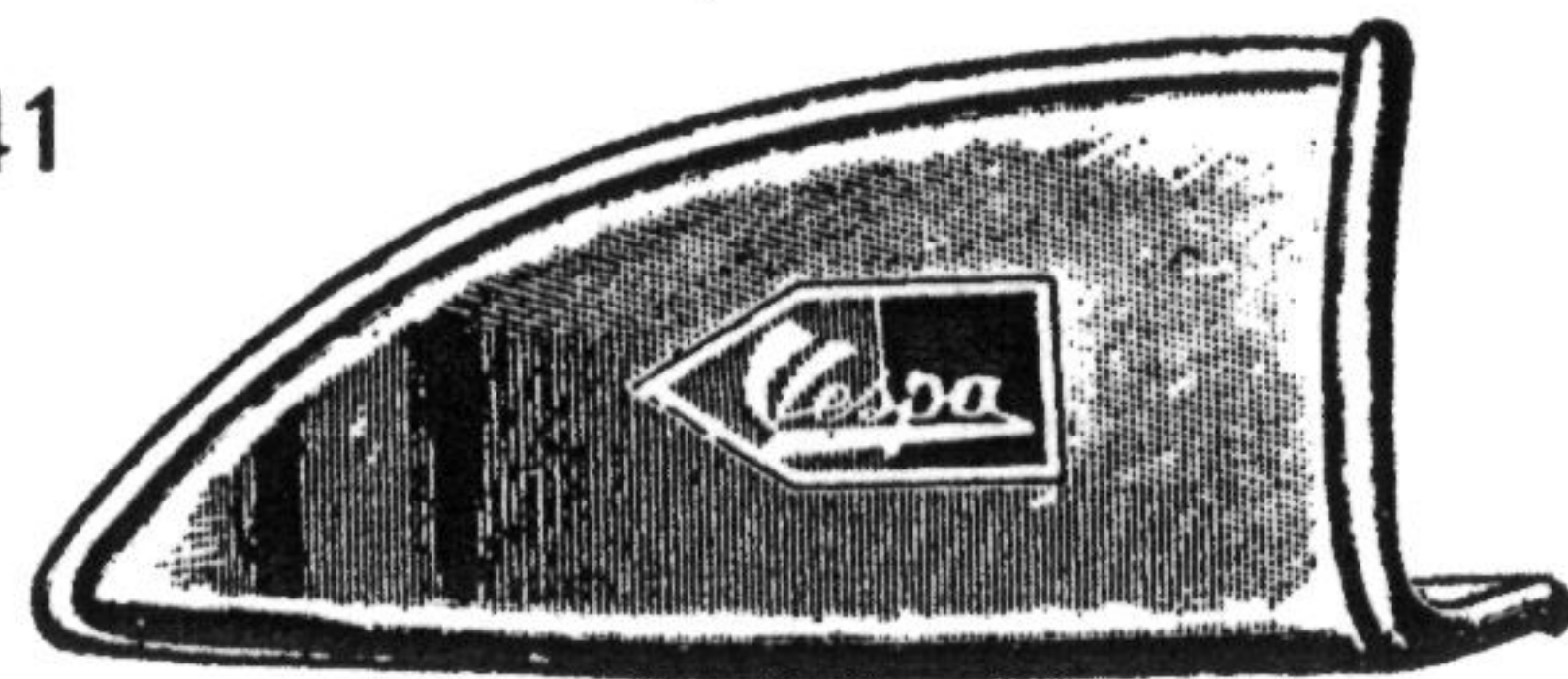

Aérateurs

841 - Aérateur, petit modèle chromé

855 - Aérateur luxe laiton chromé

Sabots d'Ailes

960 - Sabots d'ailes tubulaires laiton chromé

960

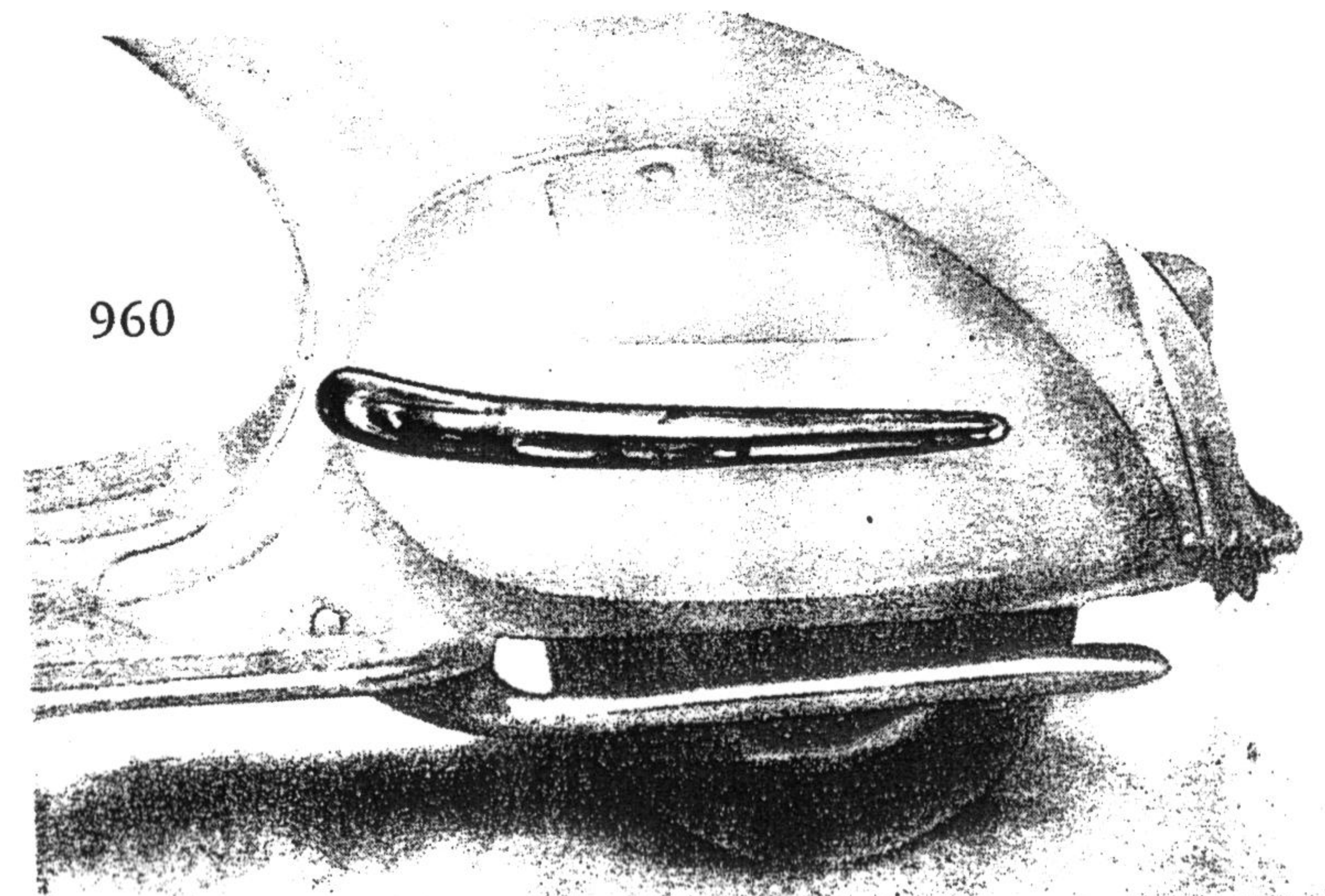



828 A



828

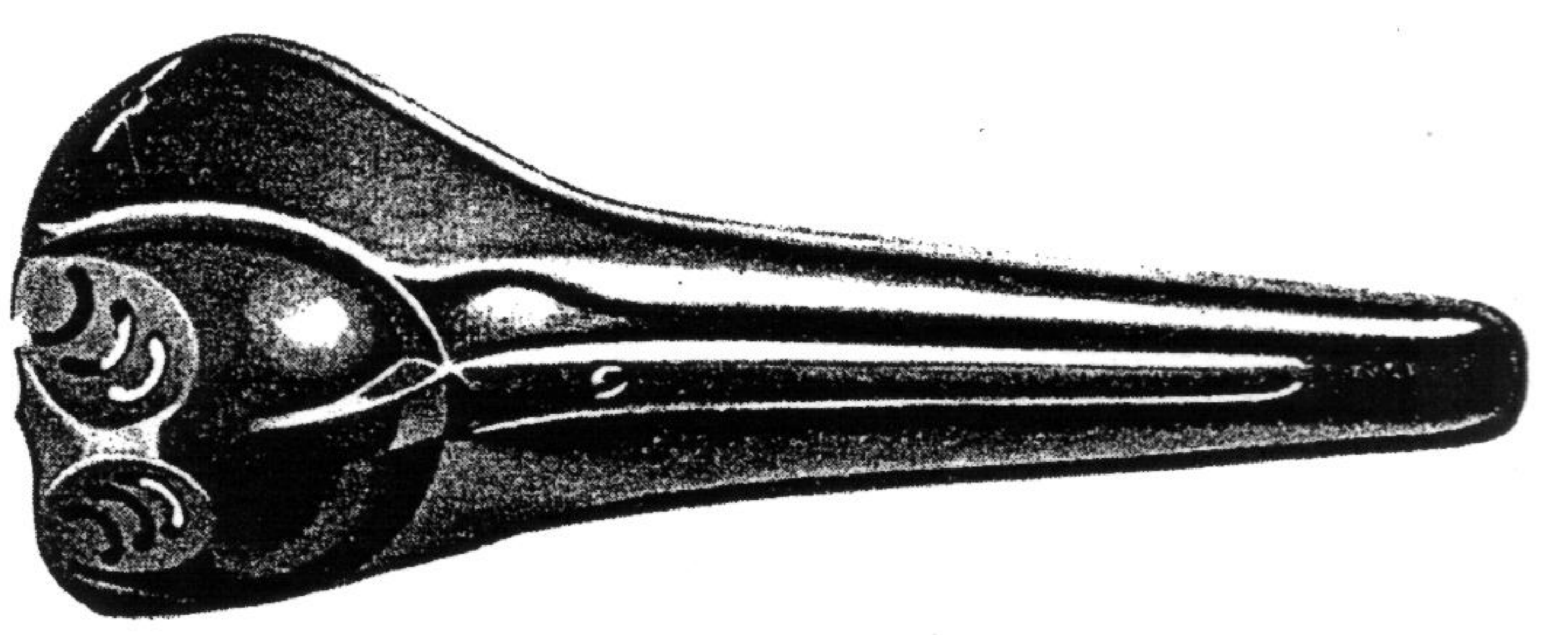

826

Enjoliveurs d'Avertisseurs



828 A - Enjoliveur d'Avertisseur
Tous modèles

828 - Enjoliveur d'Avertisseur
Type Reactor laiton chromé

826 - Calandre grand modèle
laiton chromé

813 - Calandre Grand Tourisme laiton chromé



751 - Avertisseur 6 volts standard chromé

227

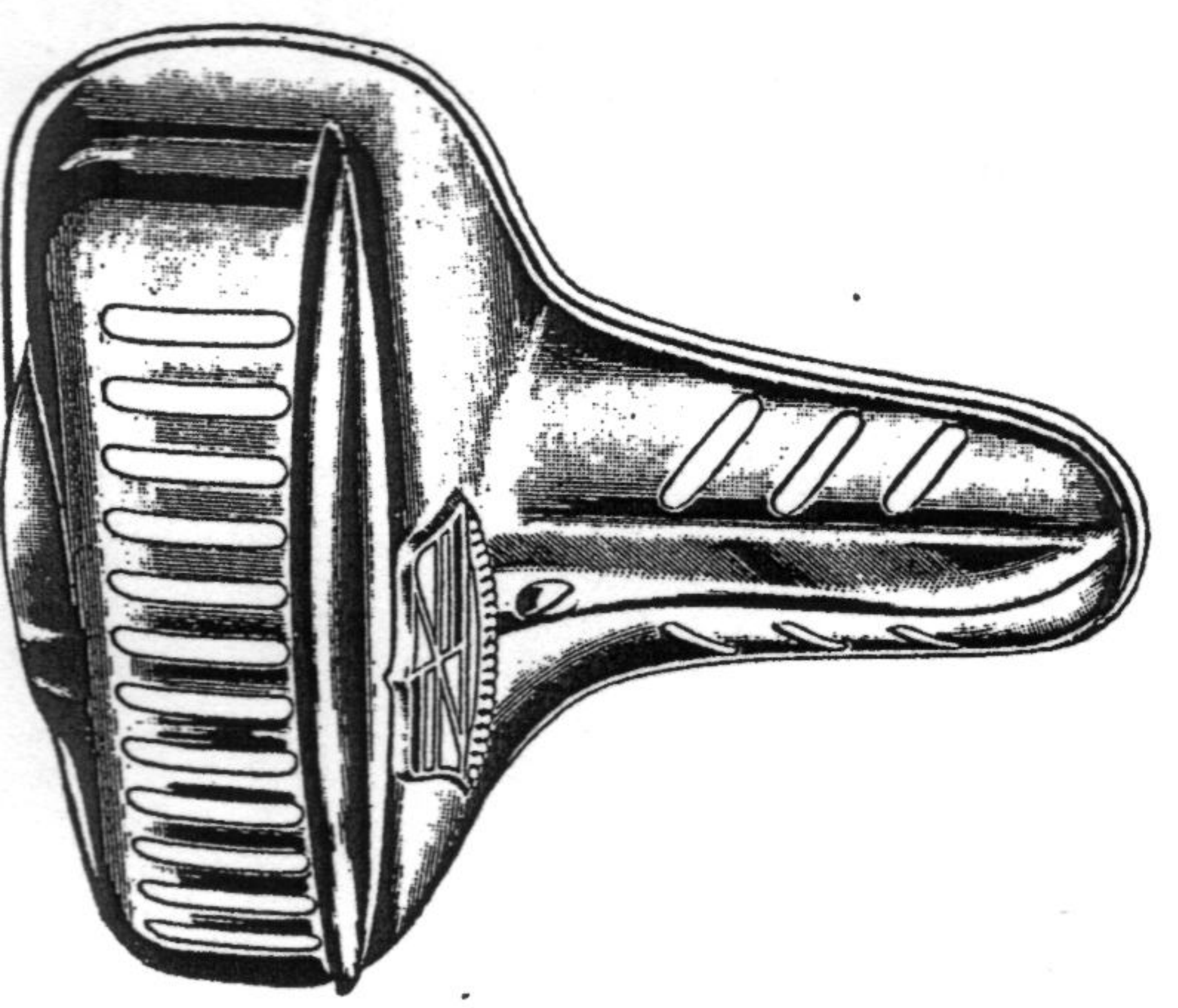

813

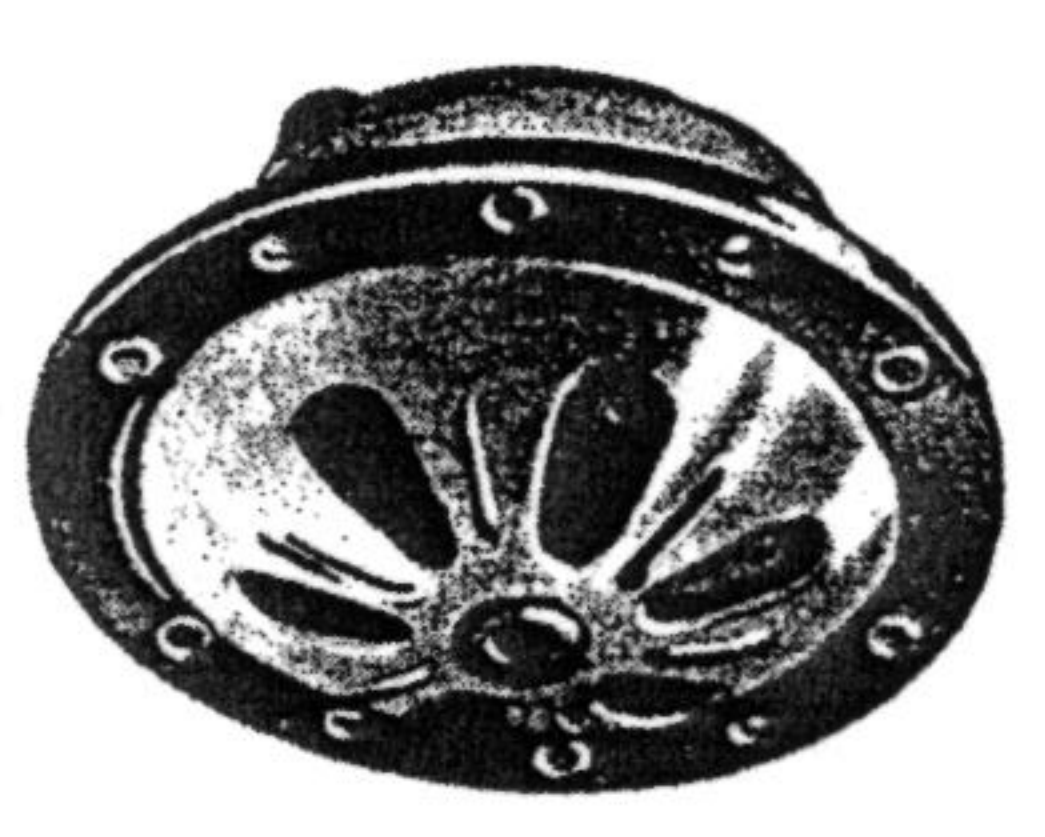

751

**De la part de
FAN DE SCOOTER**

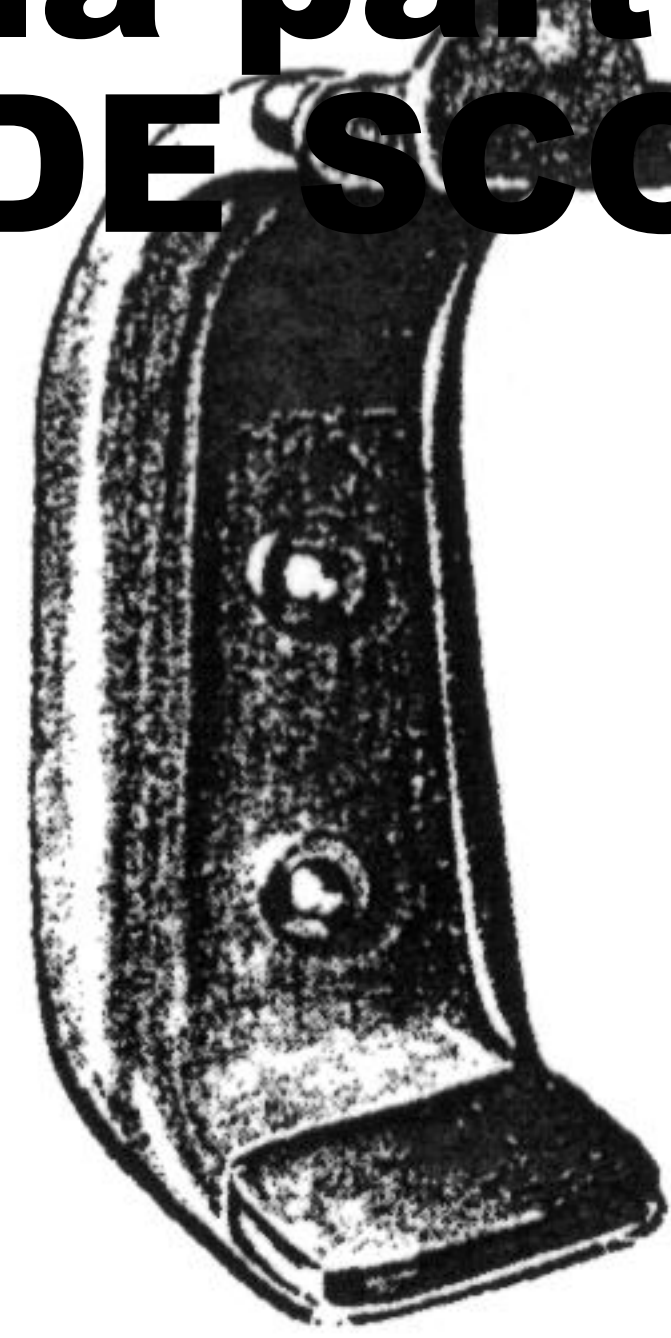

946

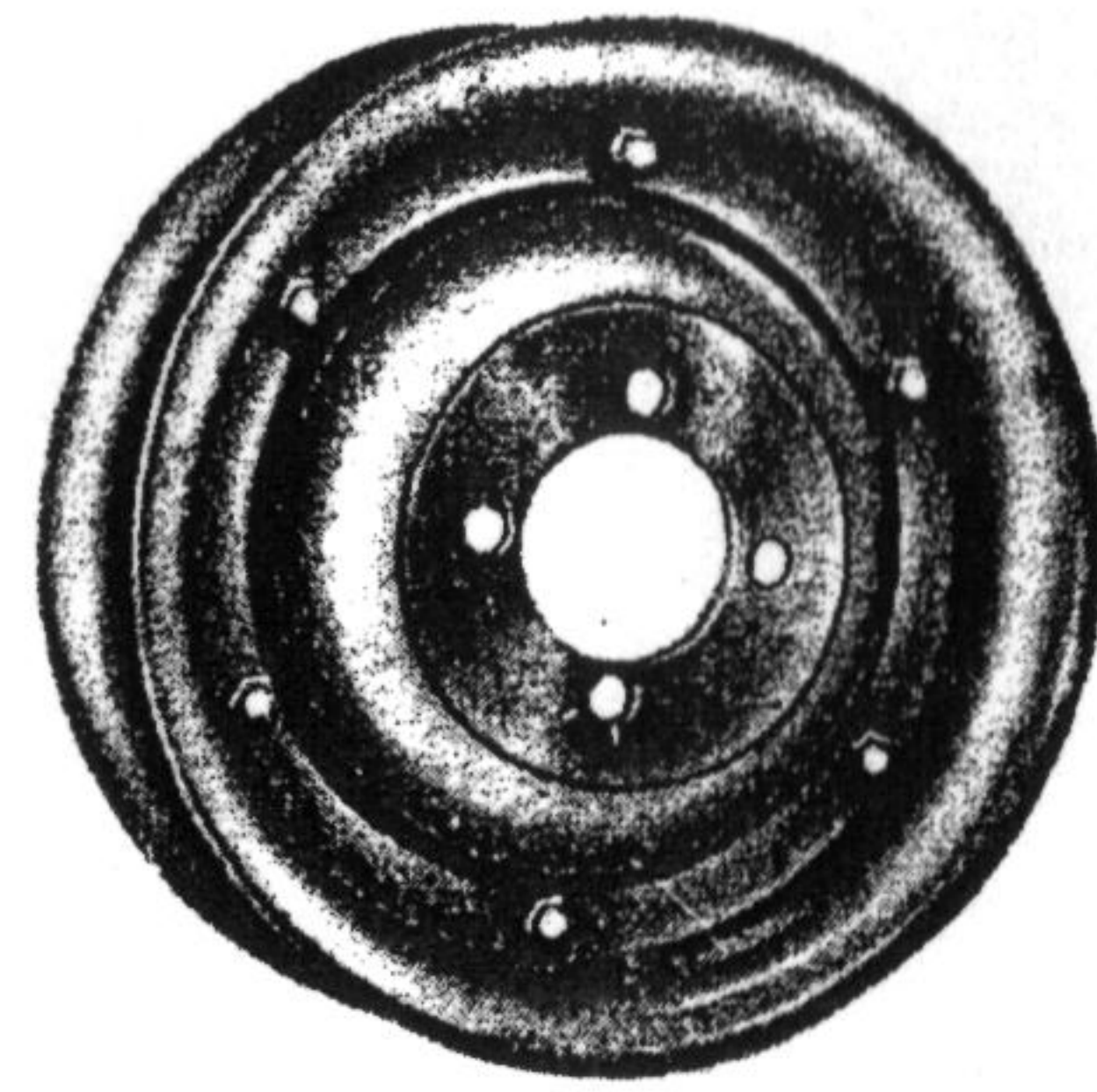

810 - 1010

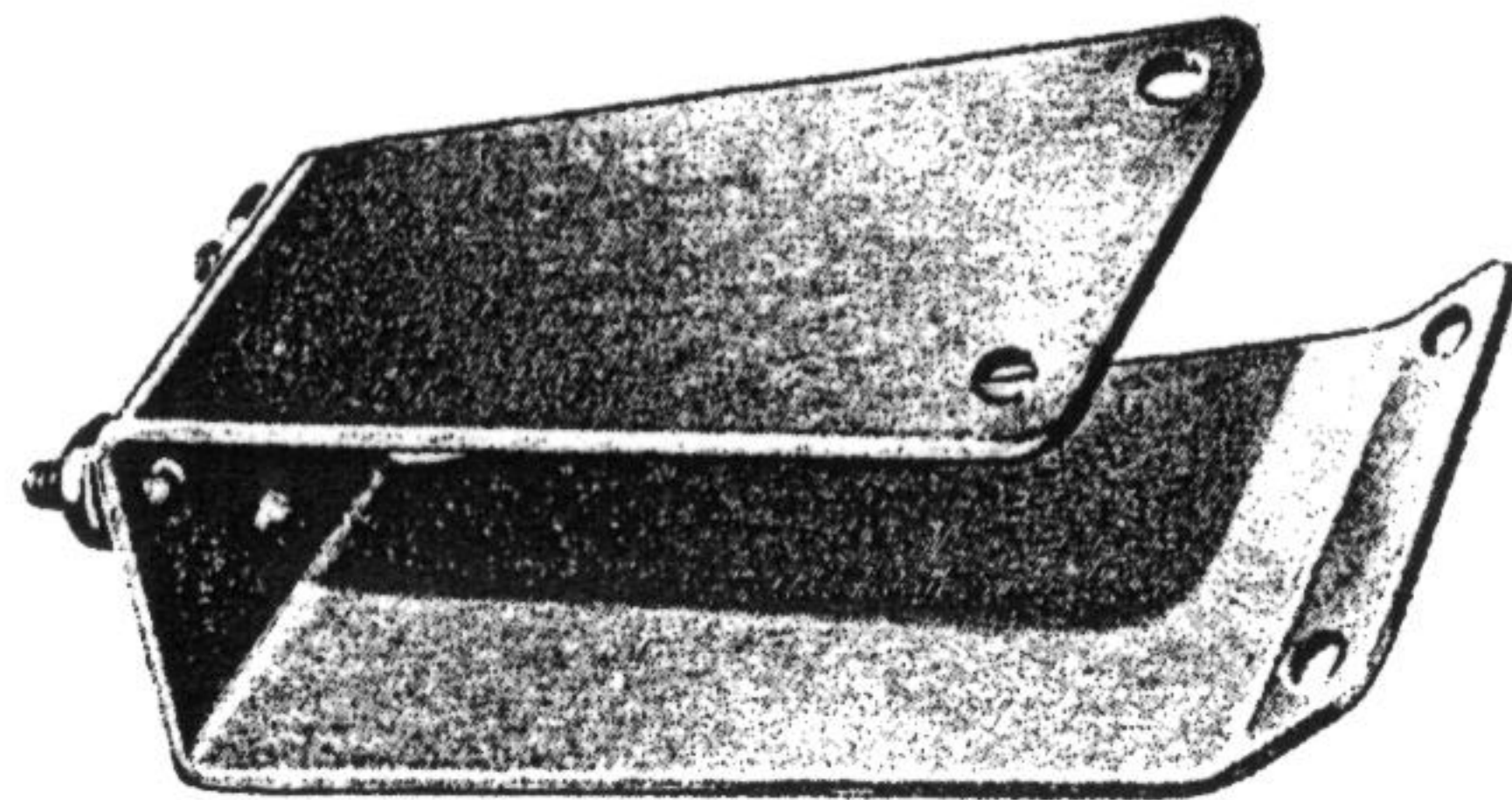

846 - 846 A

*Enjoliveurs
de Roues*

829 - Enjoliveur de Roue type France avec Eclairage

829A - Enjoliveur de Roue type Mer avec Eclairage

829B - Enjoliveur de Roue type modele avec Moll Central

915 - Enjoliveur de Roue type Artillerie laiton chromé Bouchon 2 branches

915A - Enjoliveur de Roue type Artillerie laiton chromé Bouchon 3 branches

917 - Sous-Enjoliveur pour Enjoliveur Artillerie

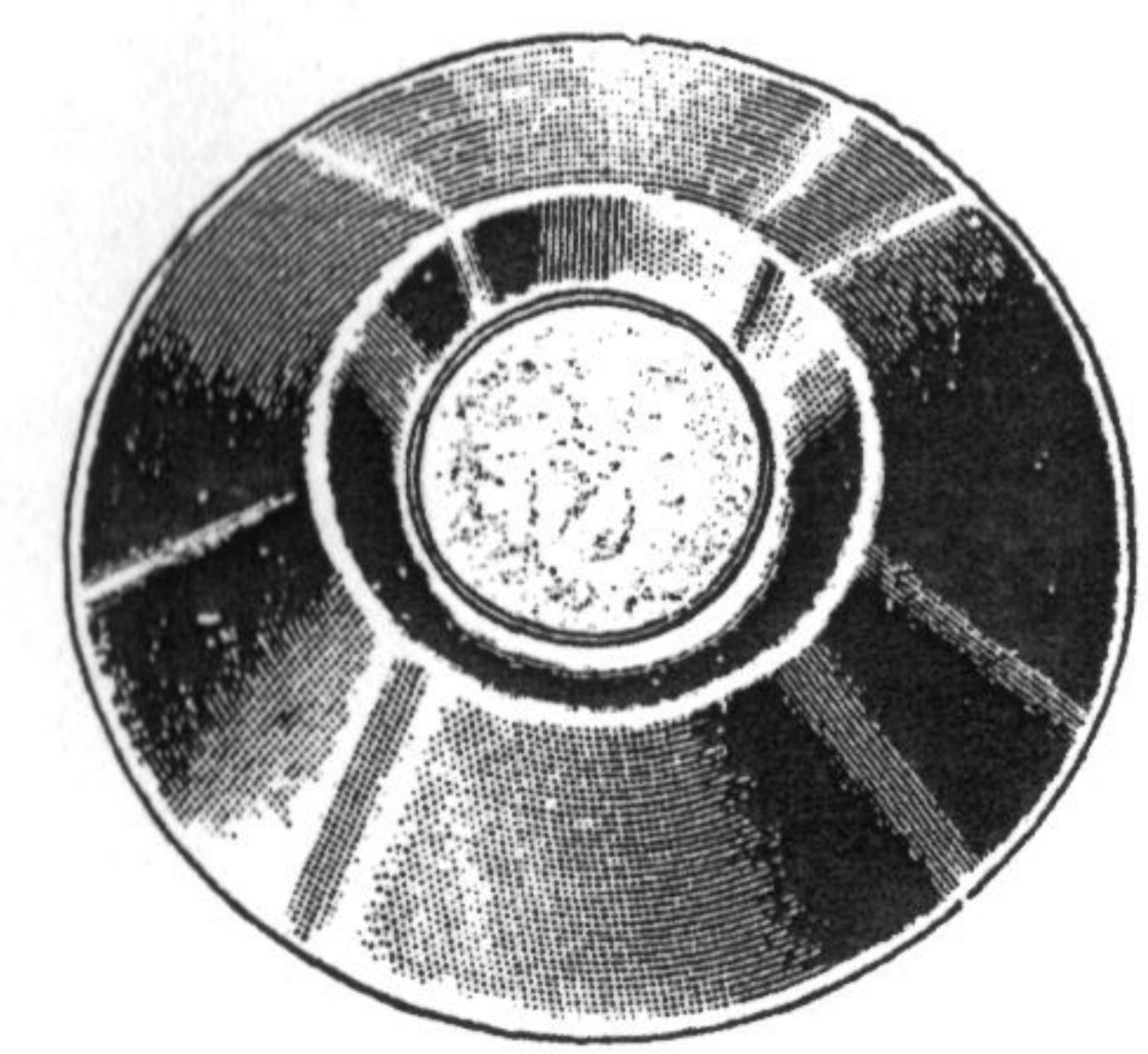

829



829 A

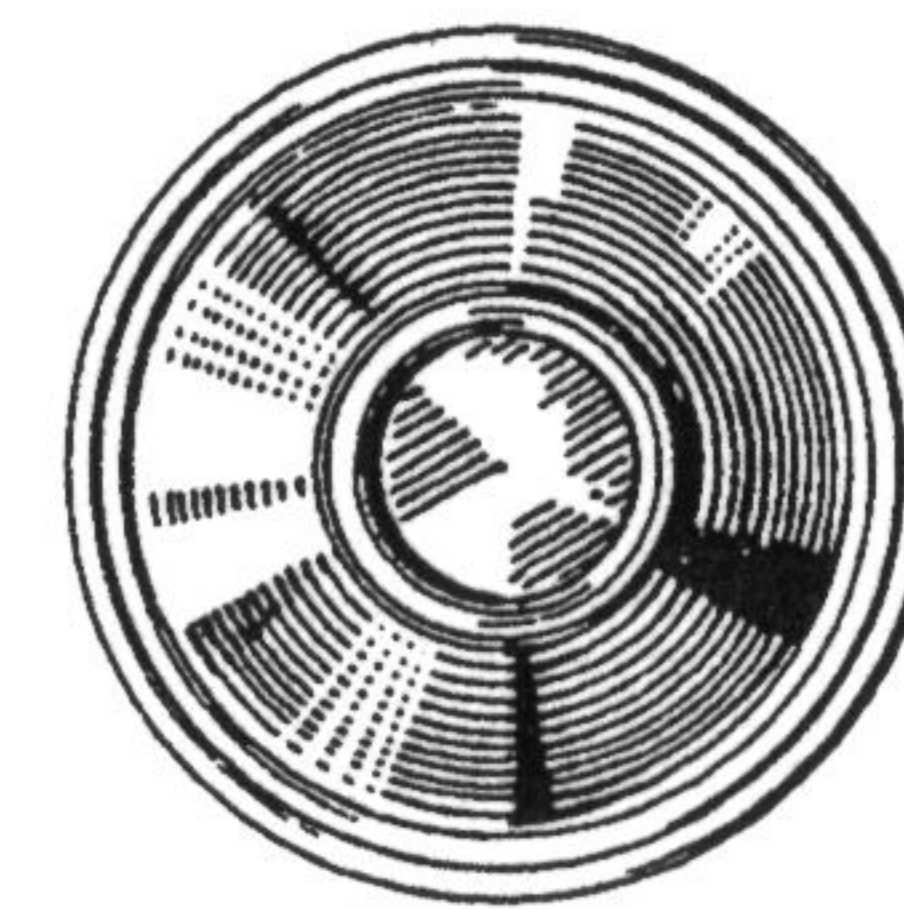

829 B

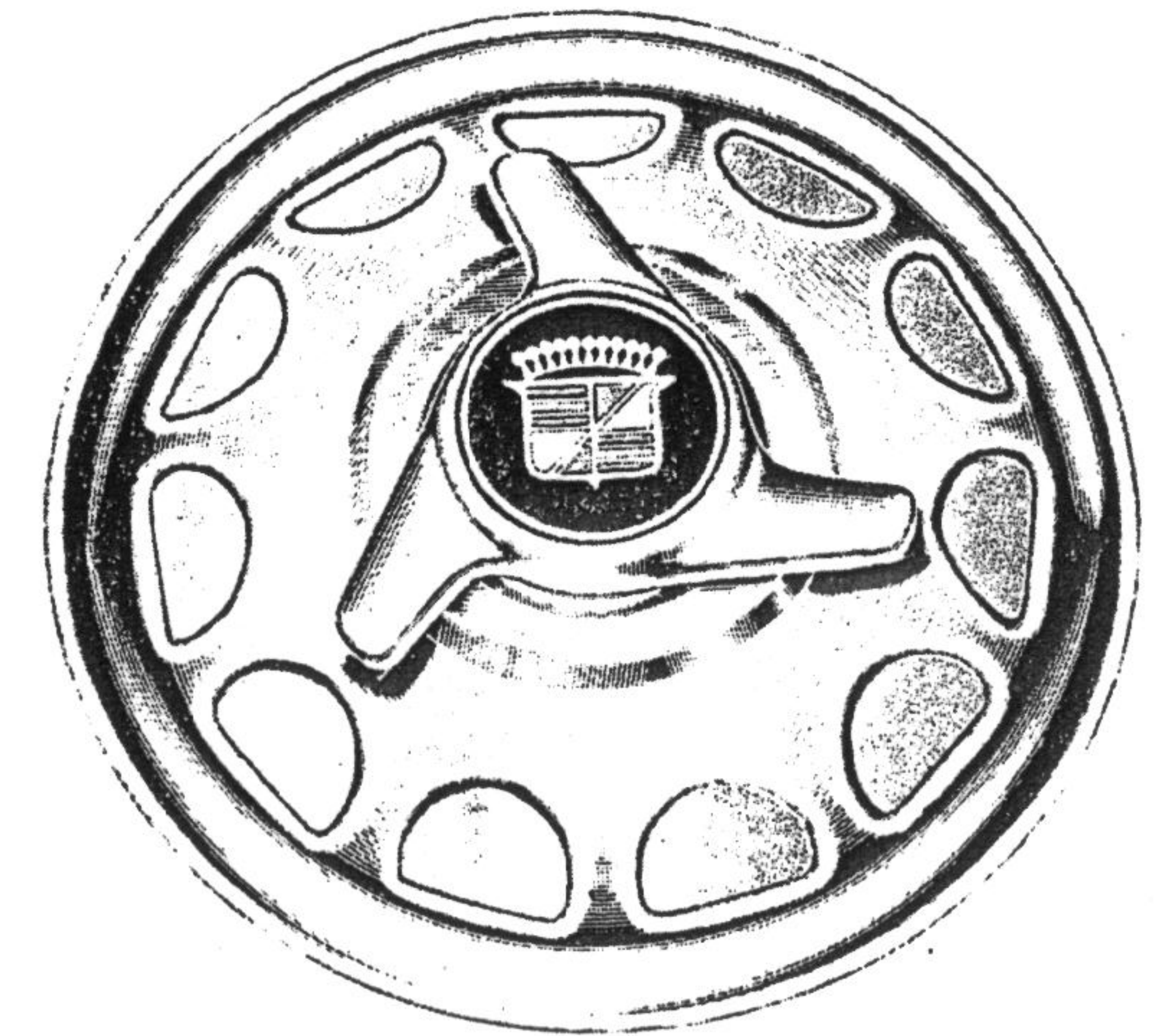

915 - 915 A - 917

946 - Support de Roue de Scooter en alliage
type modele 56

846 - Support de Roue de Scooter type
Model 55, 56

846A - Support de Roue de Scooter modele 55, 56

810 - Roue avec 1010 en alliage 2011

1010 - Roue avec 810 en alliage 2011

**De la part de
FAN DE SCOOTER**



982

982 - Enjoliveur de Roue type
"Minerva" laiton chromé



815
815 A
817

815 - Enjoliveur de Roue à rayons
laiton chromé avec
bouchon 2 branches

815 A - Enjoliveur de Roue à rayons
laiton chromé avec
bouchon 2 branches

817 - Sans Enjoliveur pour
Enjoliveur à rayons

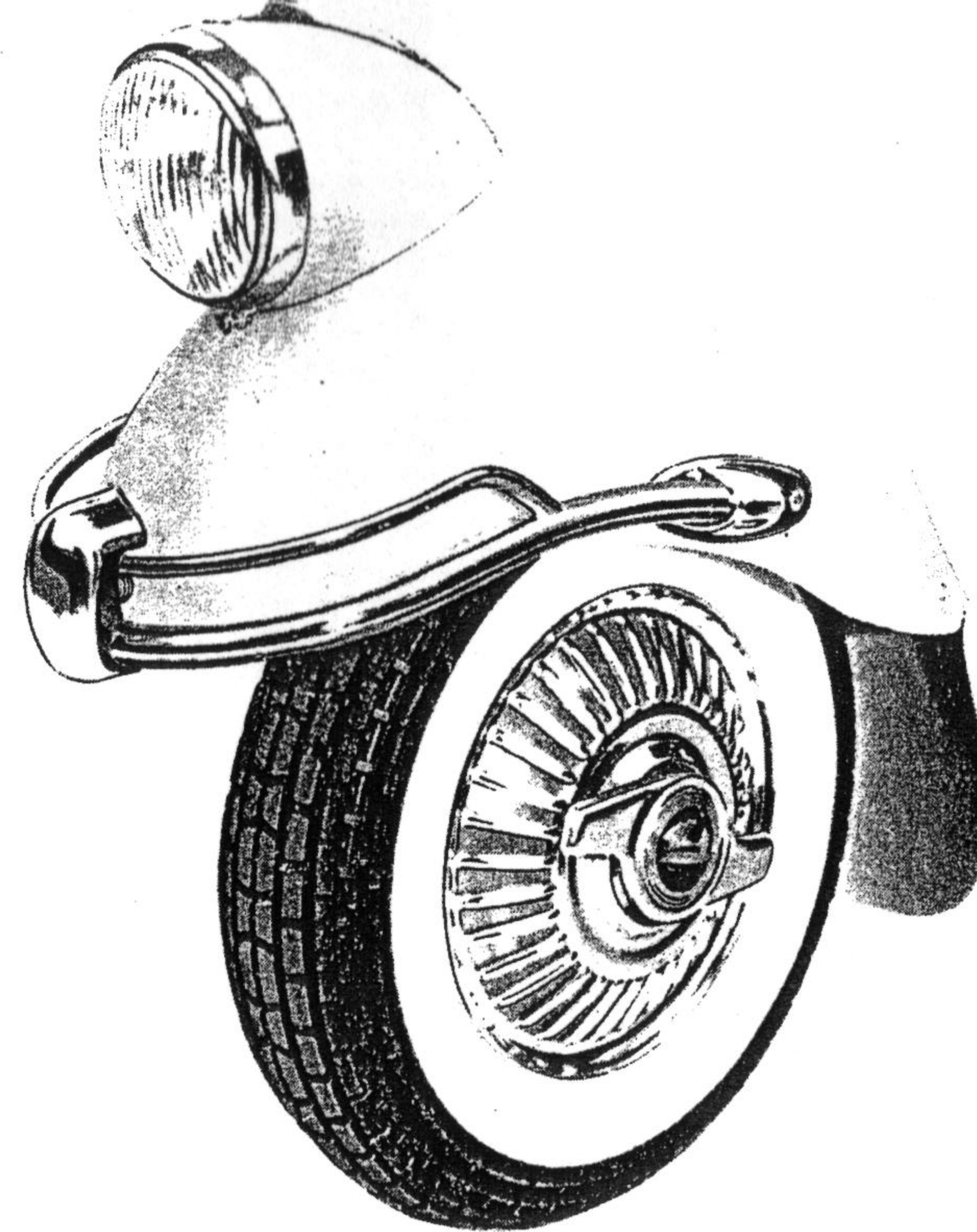

980
817

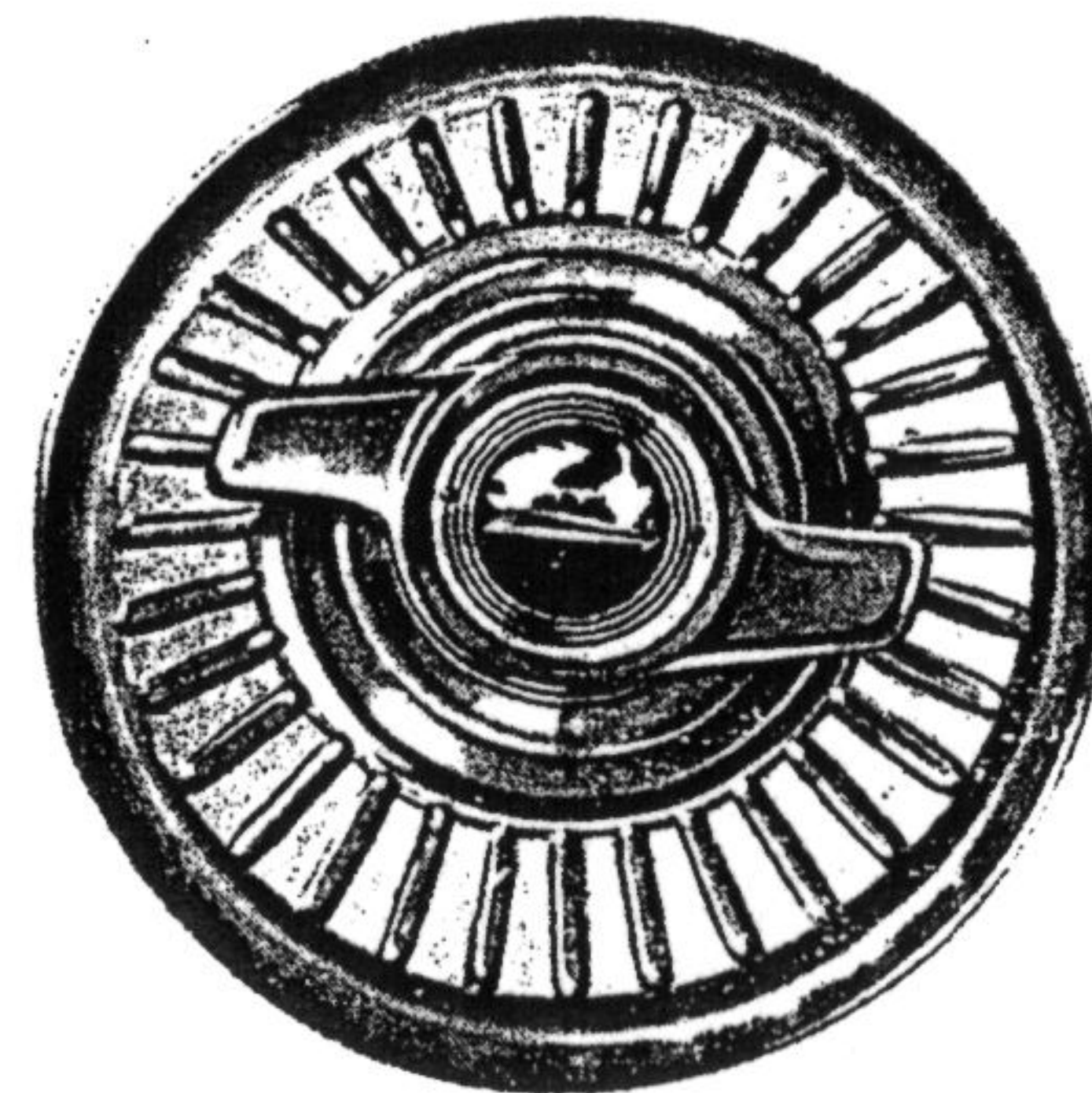

980 980 A 817

980 - Enjoliveur de Roue à rayons "Luxe 54"
laiton chromé avec bouchon 2 branches

980 A - Enjoliveur de Roue à rayons "Luxe 56"
laiton chromé avec bouchon 3 branches

817 - Sans Enjoliveur pour Enjoliveur à rayons

De la part de FAN DE SCOOTER

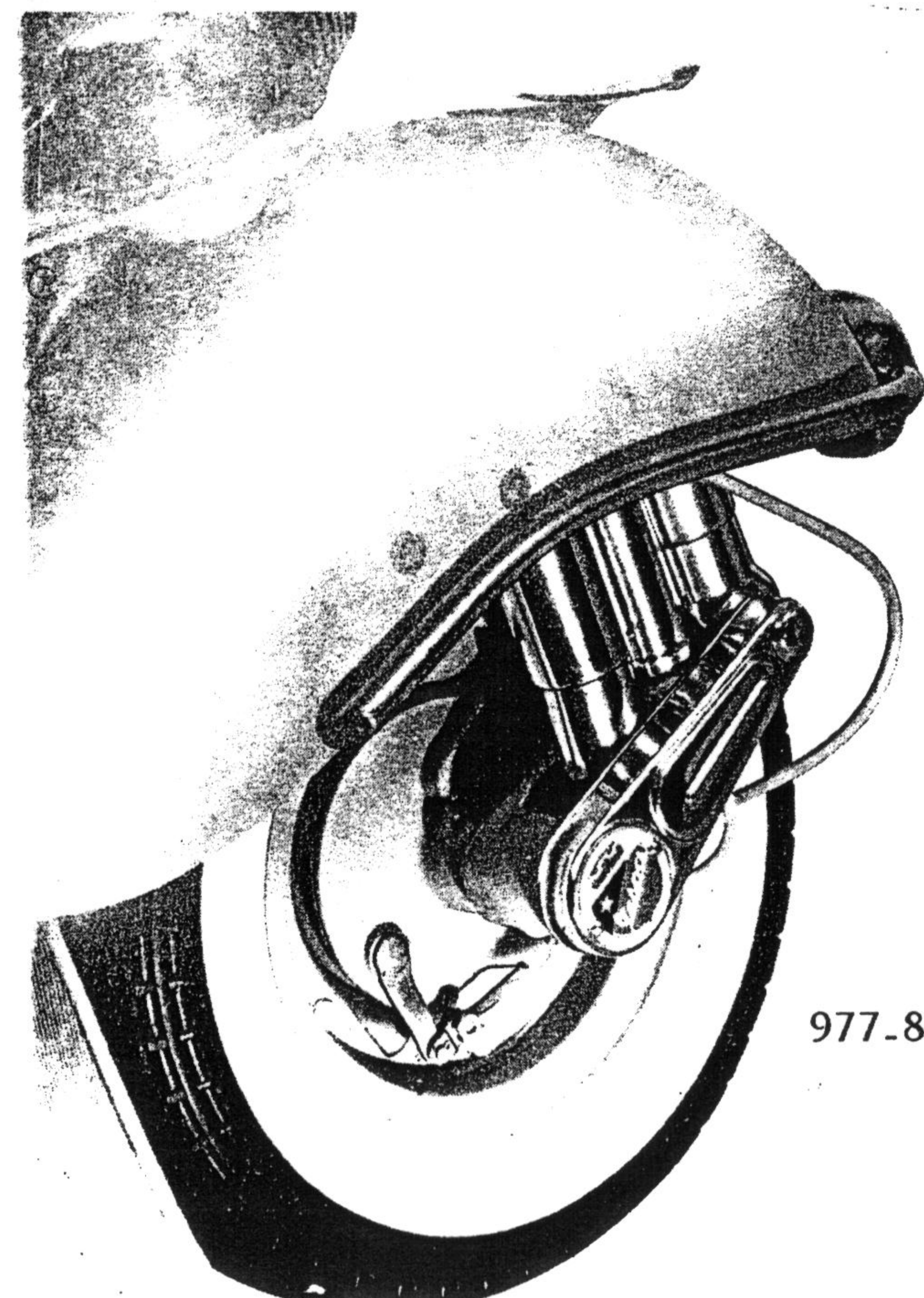
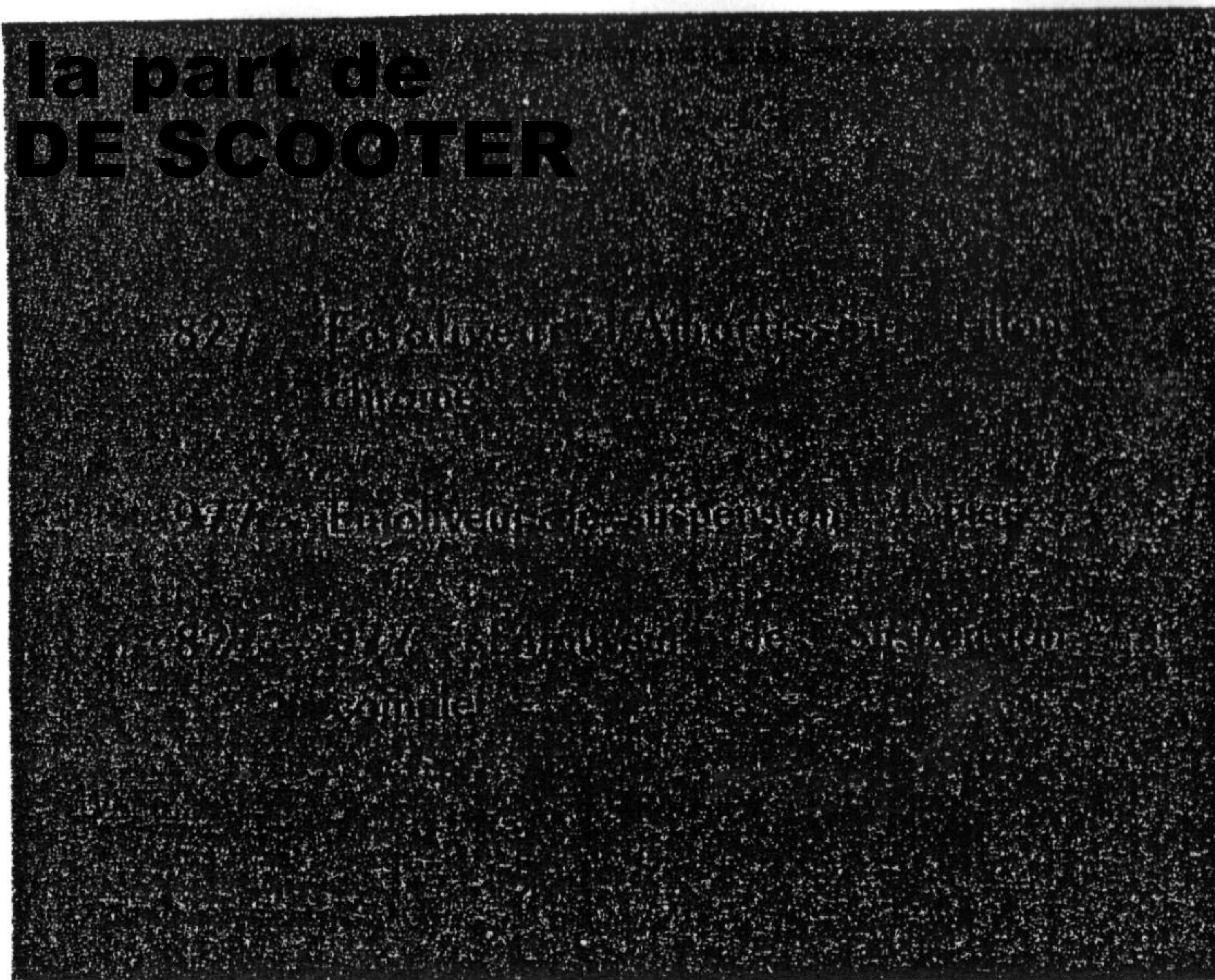

977-827

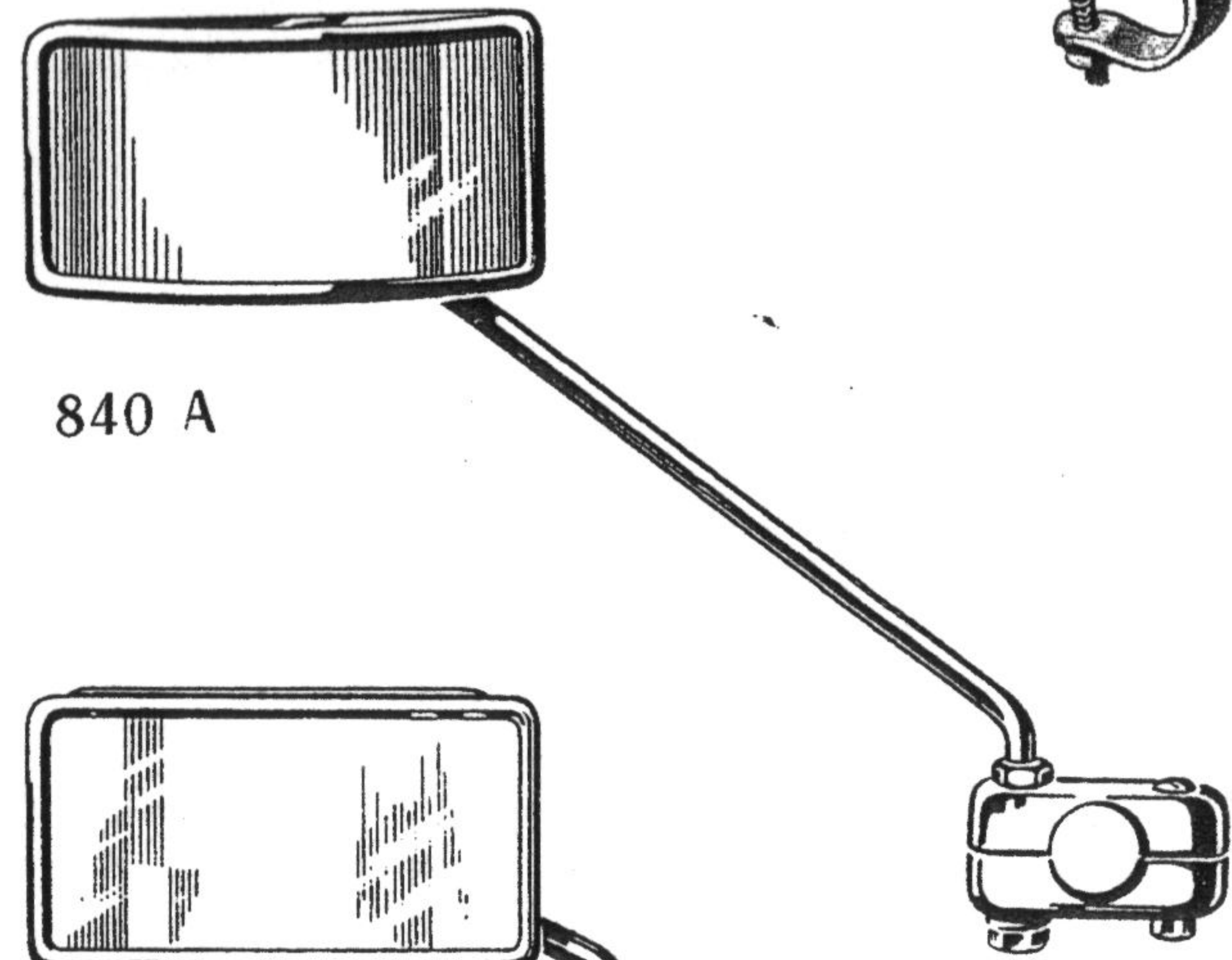
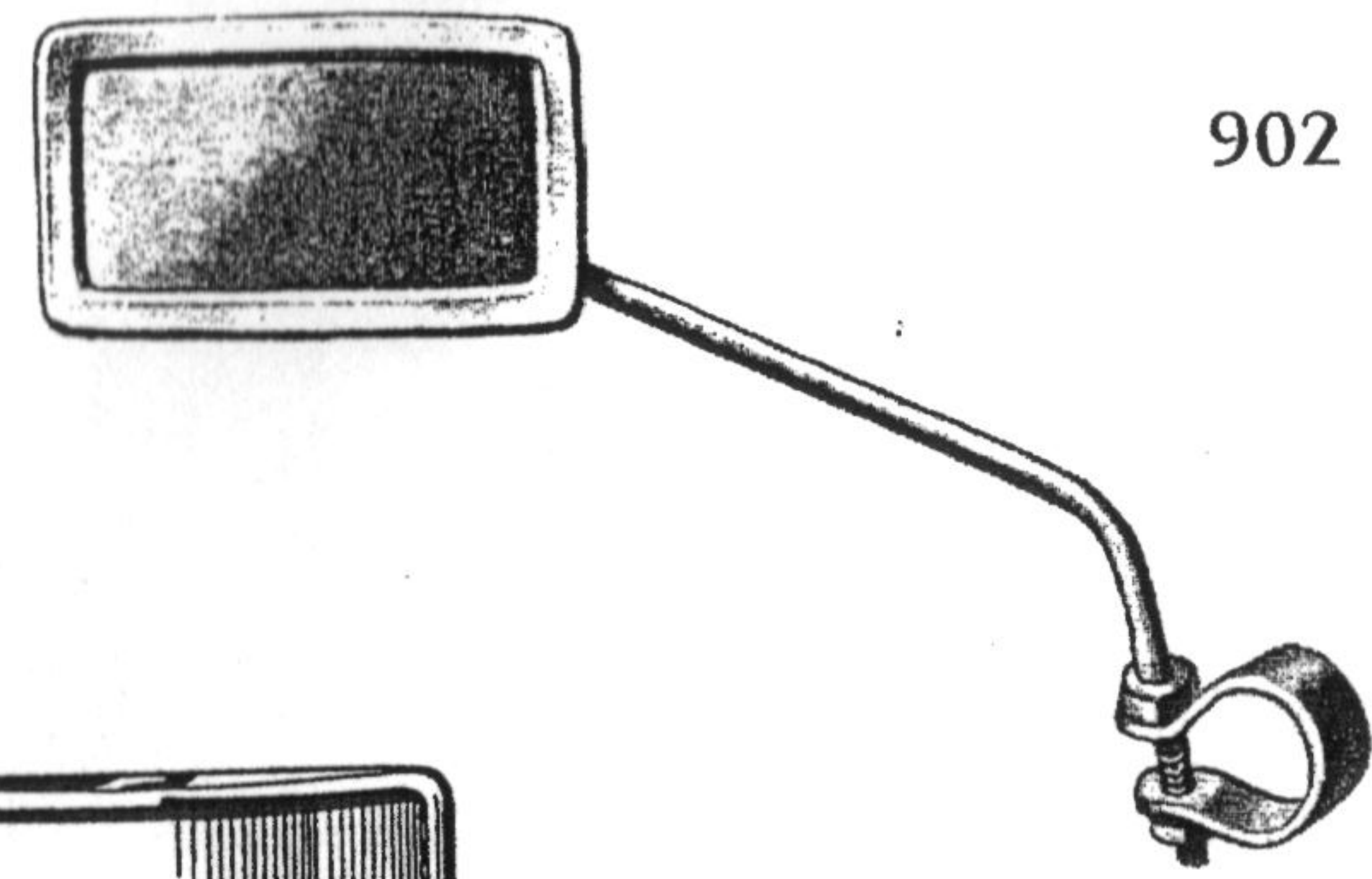
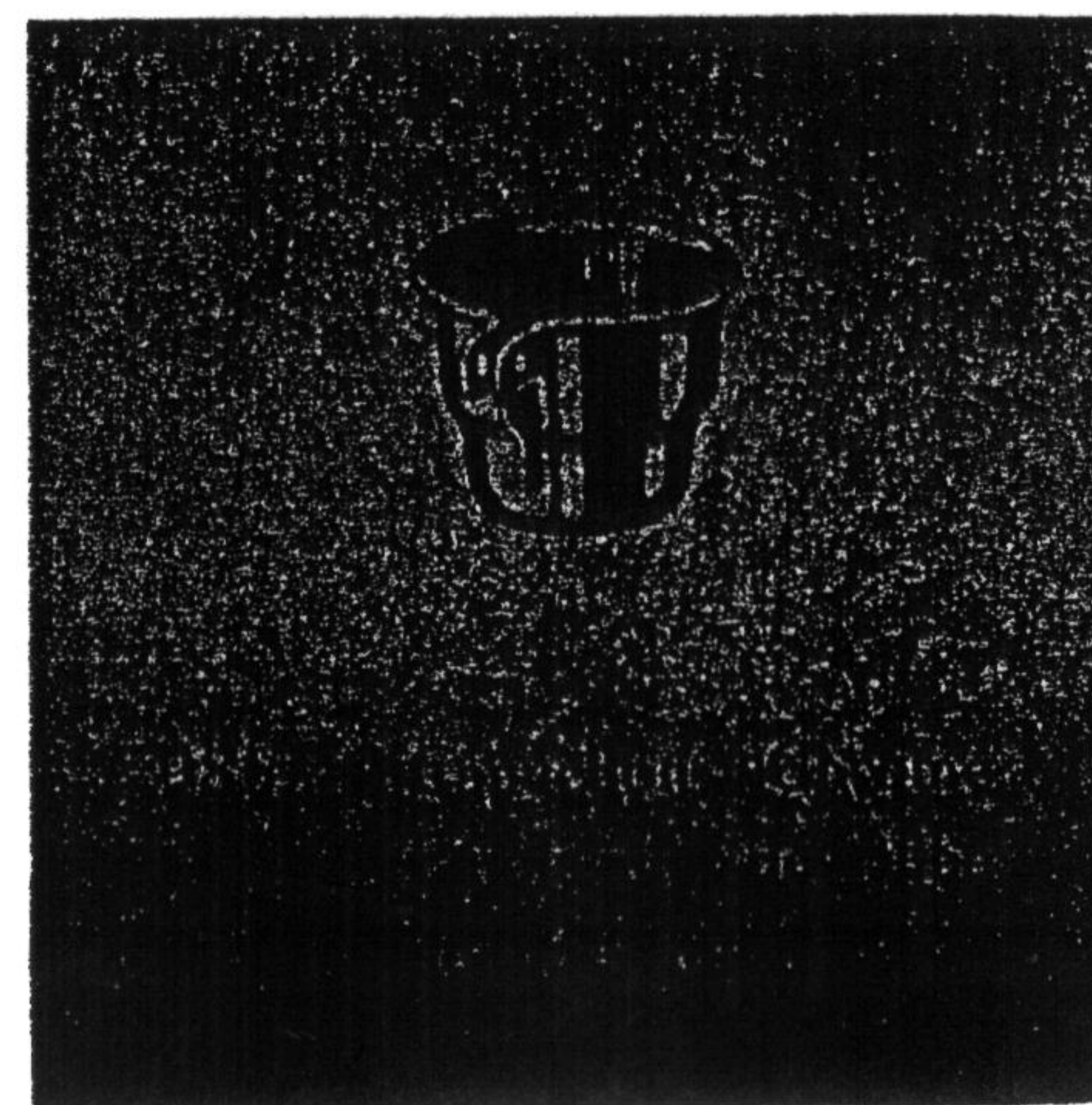
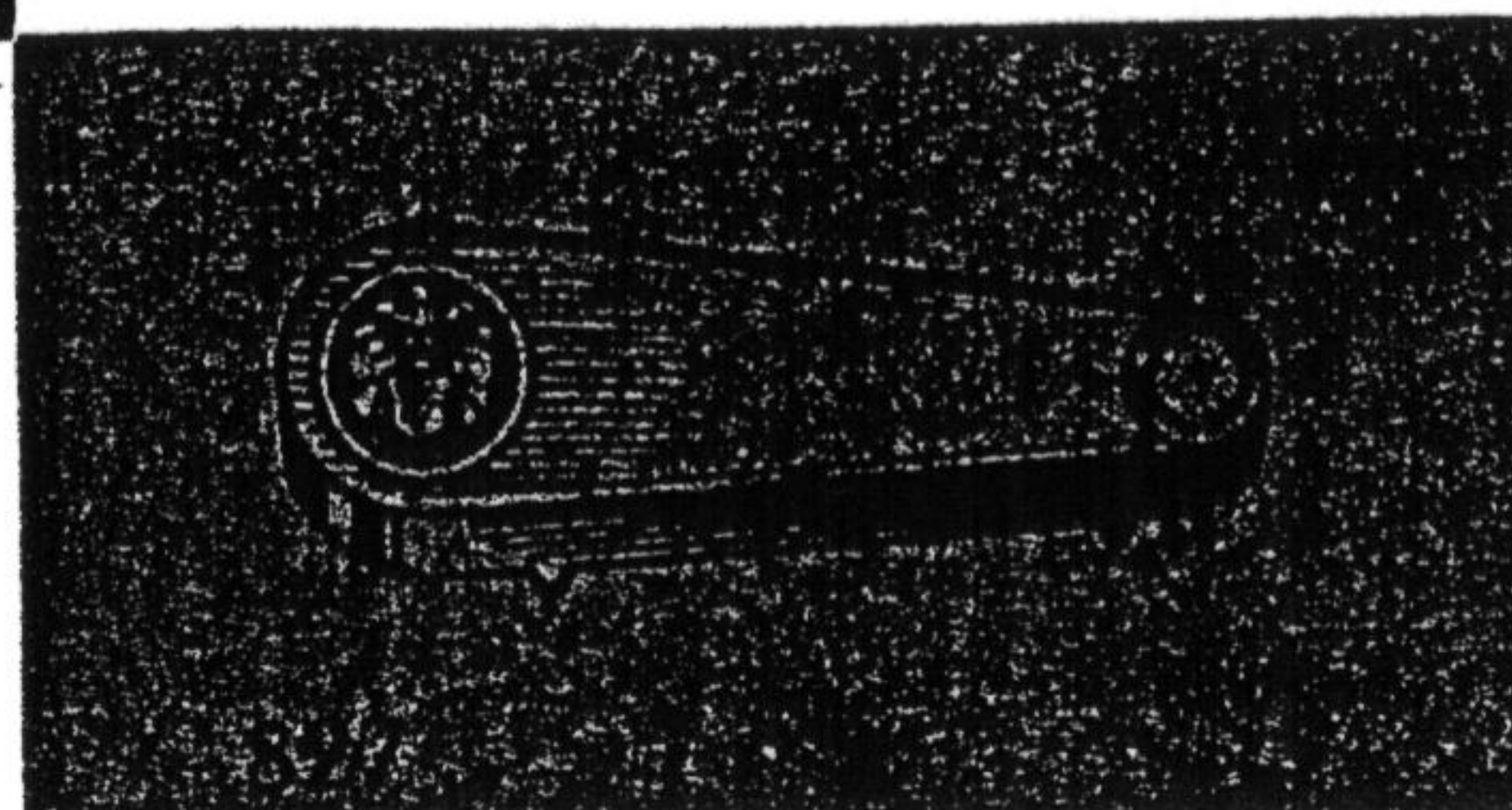

840 A

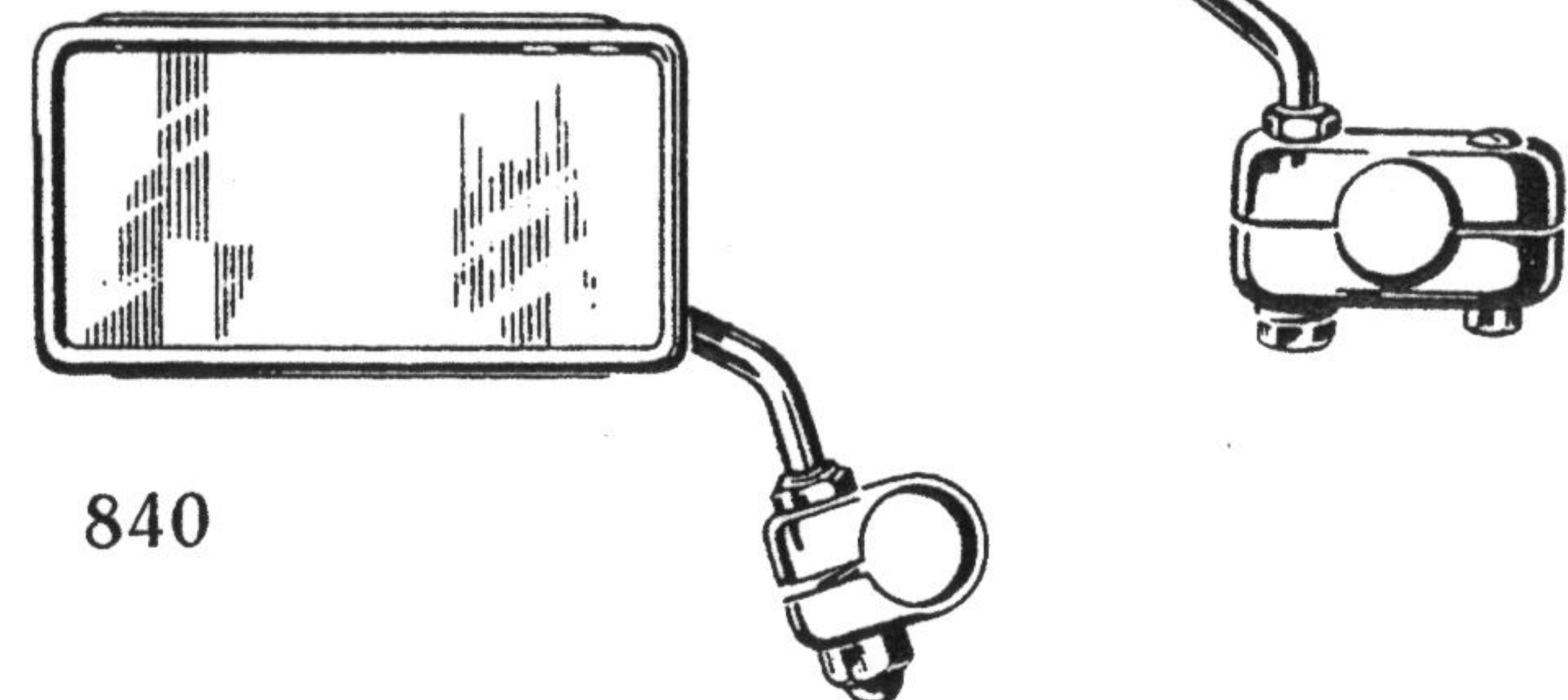

840

Rétroviseurs

- 902 - Rétroviseur petit modèle rectangulaire
glace bombée
- 840 - Rétroviseur rectangulaire, tige courte
glace plate, entièrement chromé
- 840A - Rétroviseur rectangulaire, tige longue
glace bombée, entièrement chromé

961/2

De la part de FAN DE SCOOTER

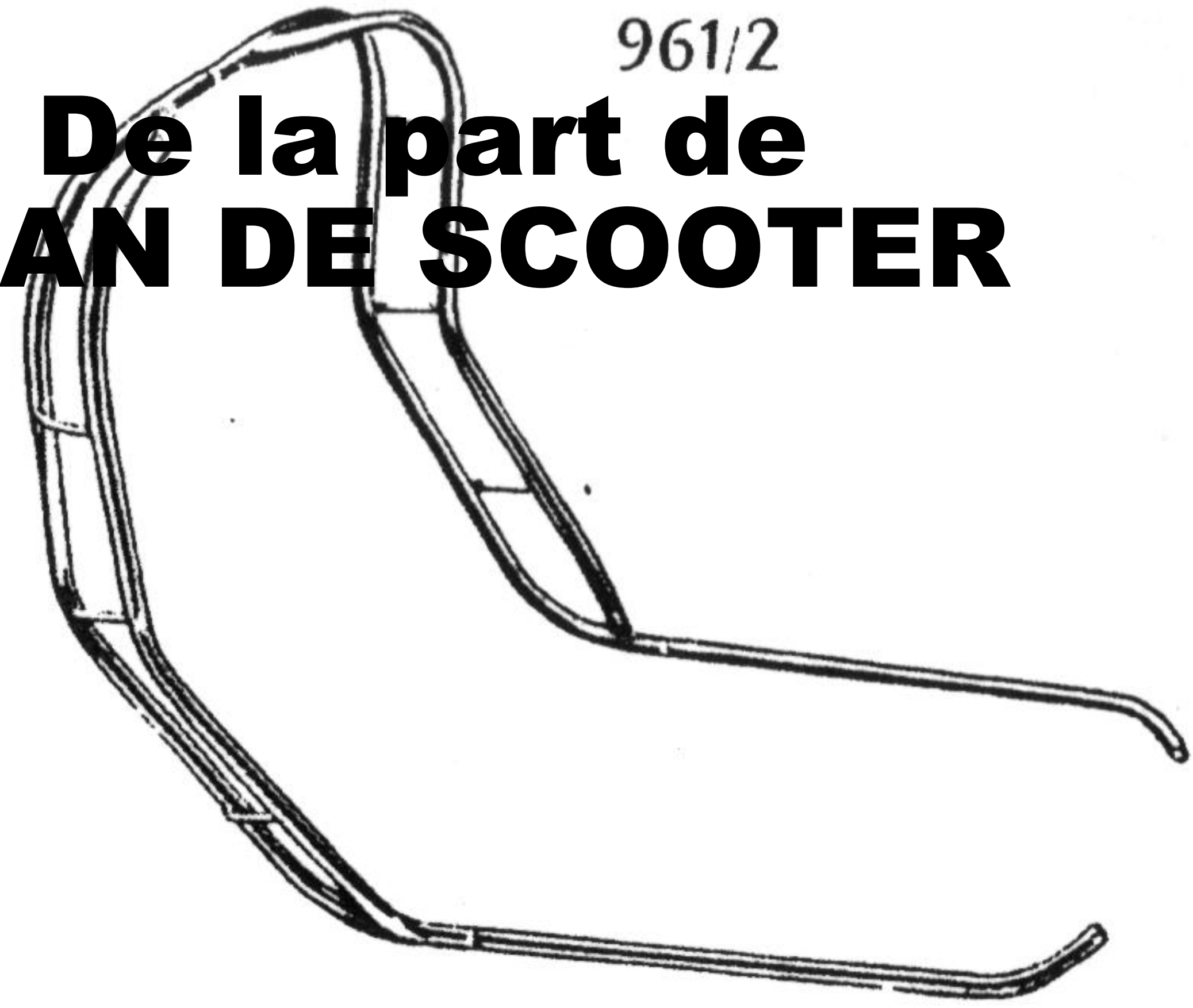

962

961/2 - Enjoliveur Protecteur de Tablier double 4 pièces, acier cuivré nickelé chromé

962 - Prolongement de Protecteur 4 pièces

961 - Enjoliveur Protecteur de Tablier double 2 Pièces, acier cuivré nickelé chromé

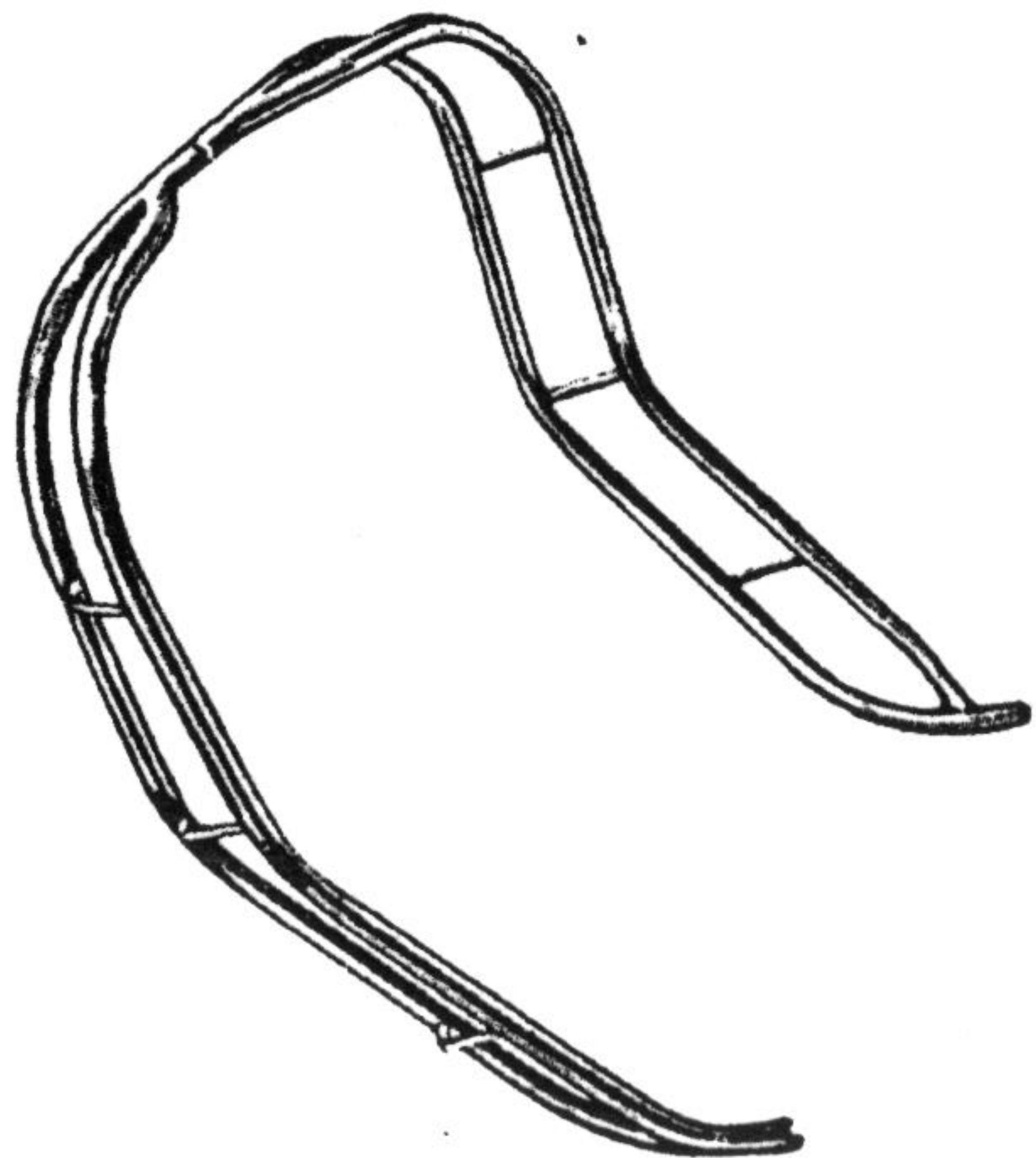

961

Enjoliveurs

Protecteurs de Tabliers



856 - Enjoliveur Protecteur de Tablier laiton chromé 3 pièces avec grand motif central

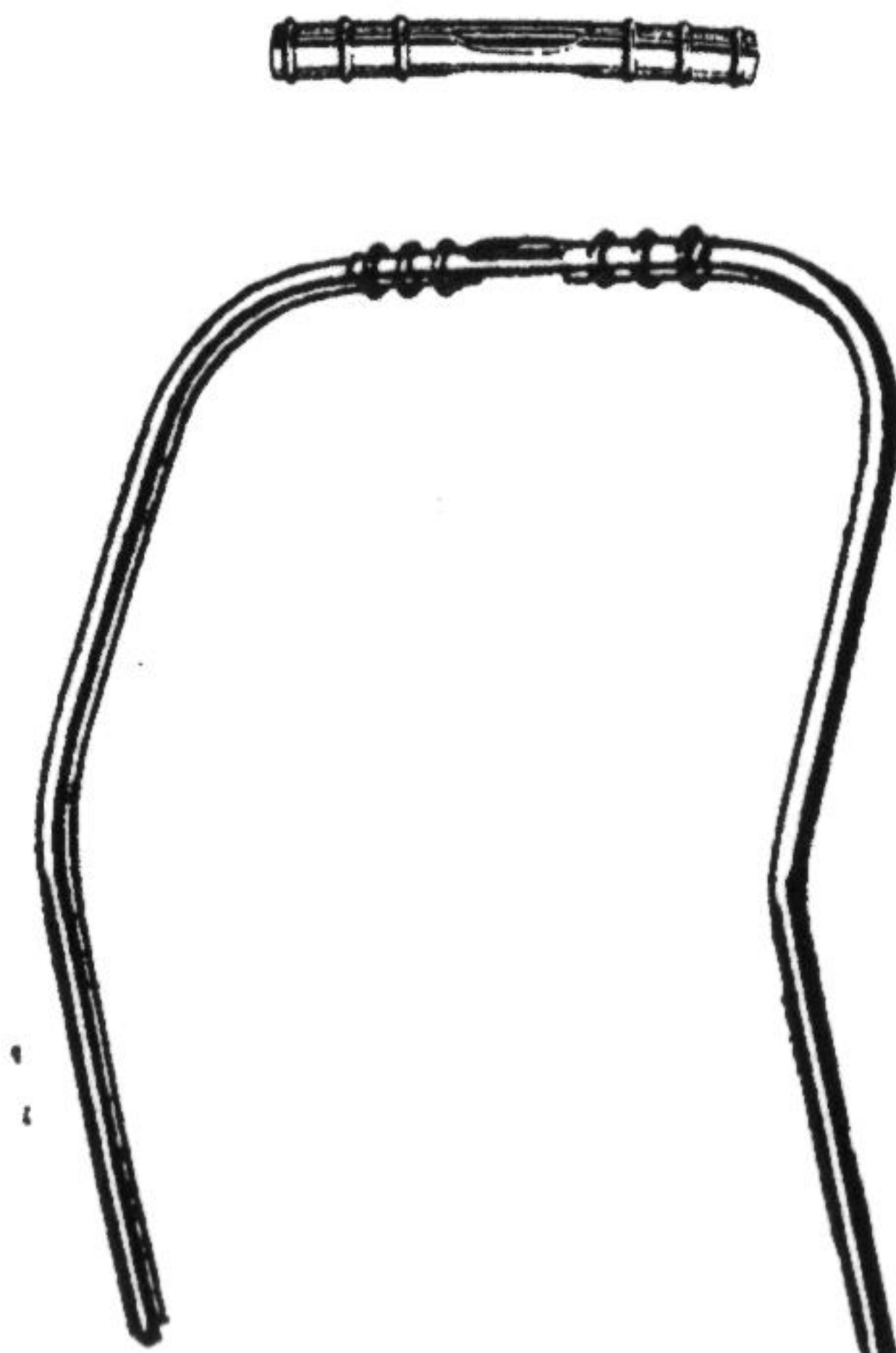

856

931

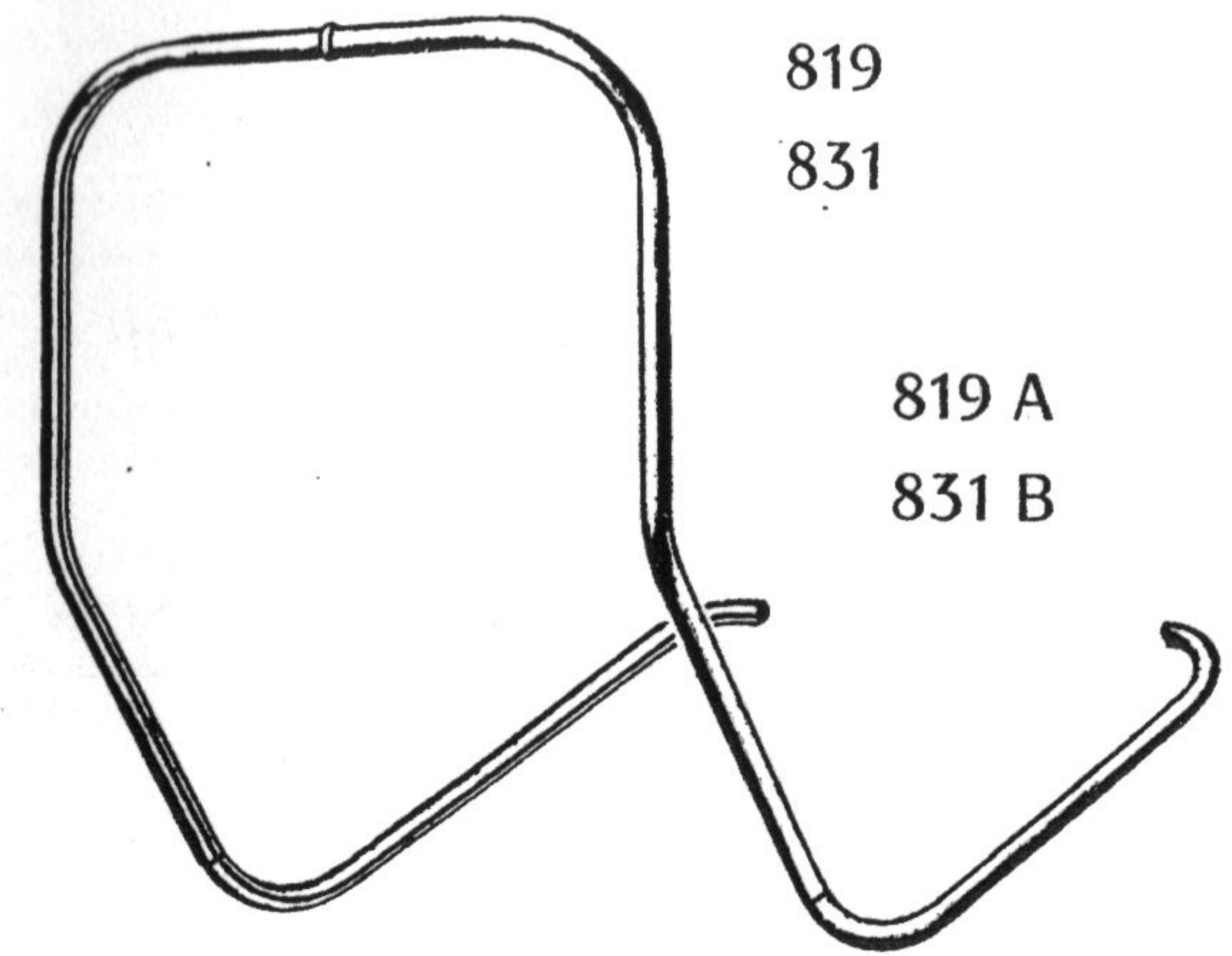

819

831

819 A

831 B

819 - Enjoliveur Protecteur de Tablier, laiton chromé, 4 pièces

819 A - Prolongement de Protecteur, laiton, 4 p.

831 - Enjoliveur Protecteur de Tablier, acier cuivré nickelé chromé, 4 pièces

831 B - Prolongement de Protecteur, Acier, 4 p.

820 - Enjoliveur Protecteur de Tablier, laiton chromé, 2 pièces

830 - Enjoliveur Protecteur de Tablier, acier cuivré nickelé chromé, 2 pièces

820

830

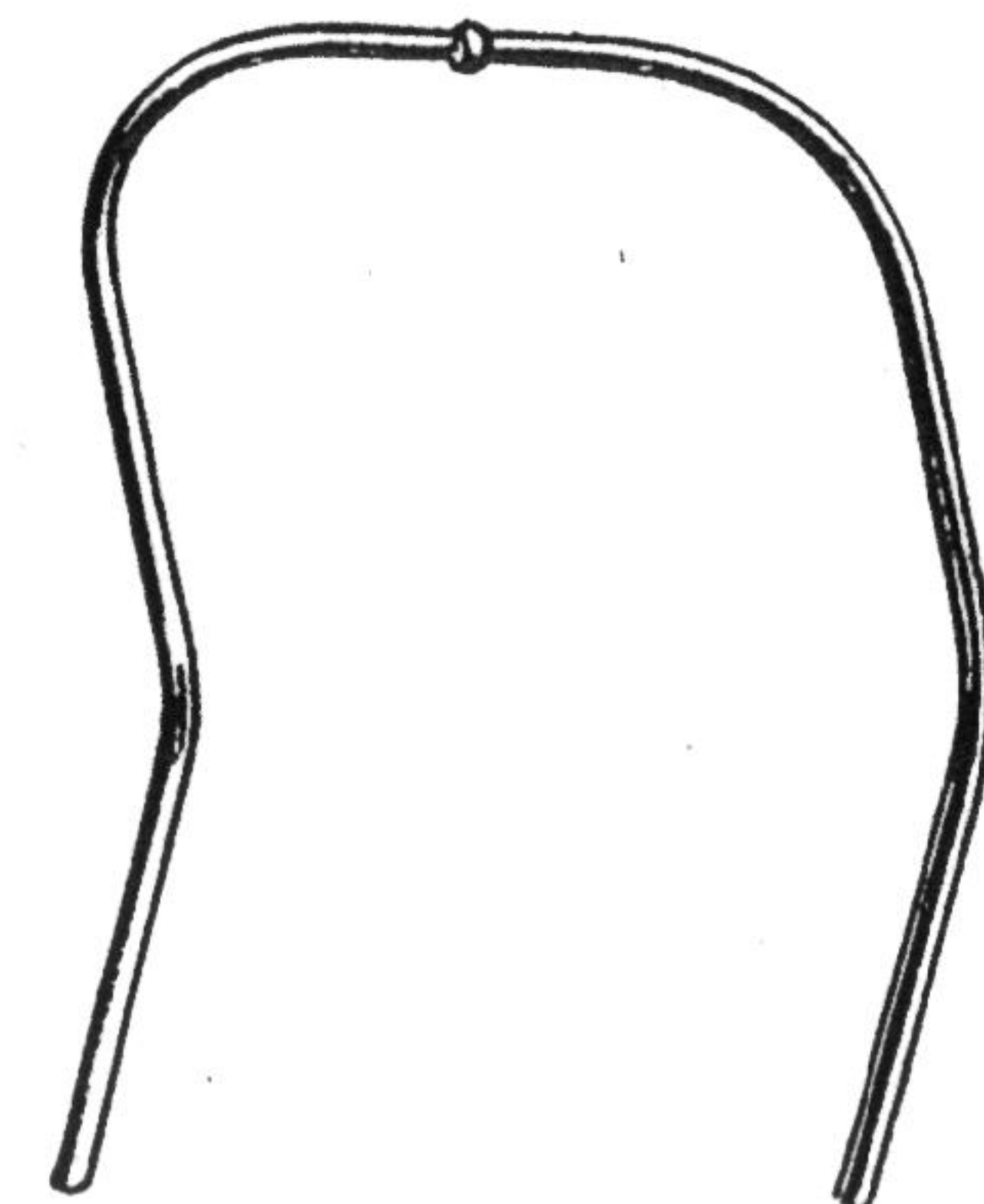

De la part de Coffres FAN DE SCOOTER

705 - Coffre métallique de tablier émaillé avec serrure

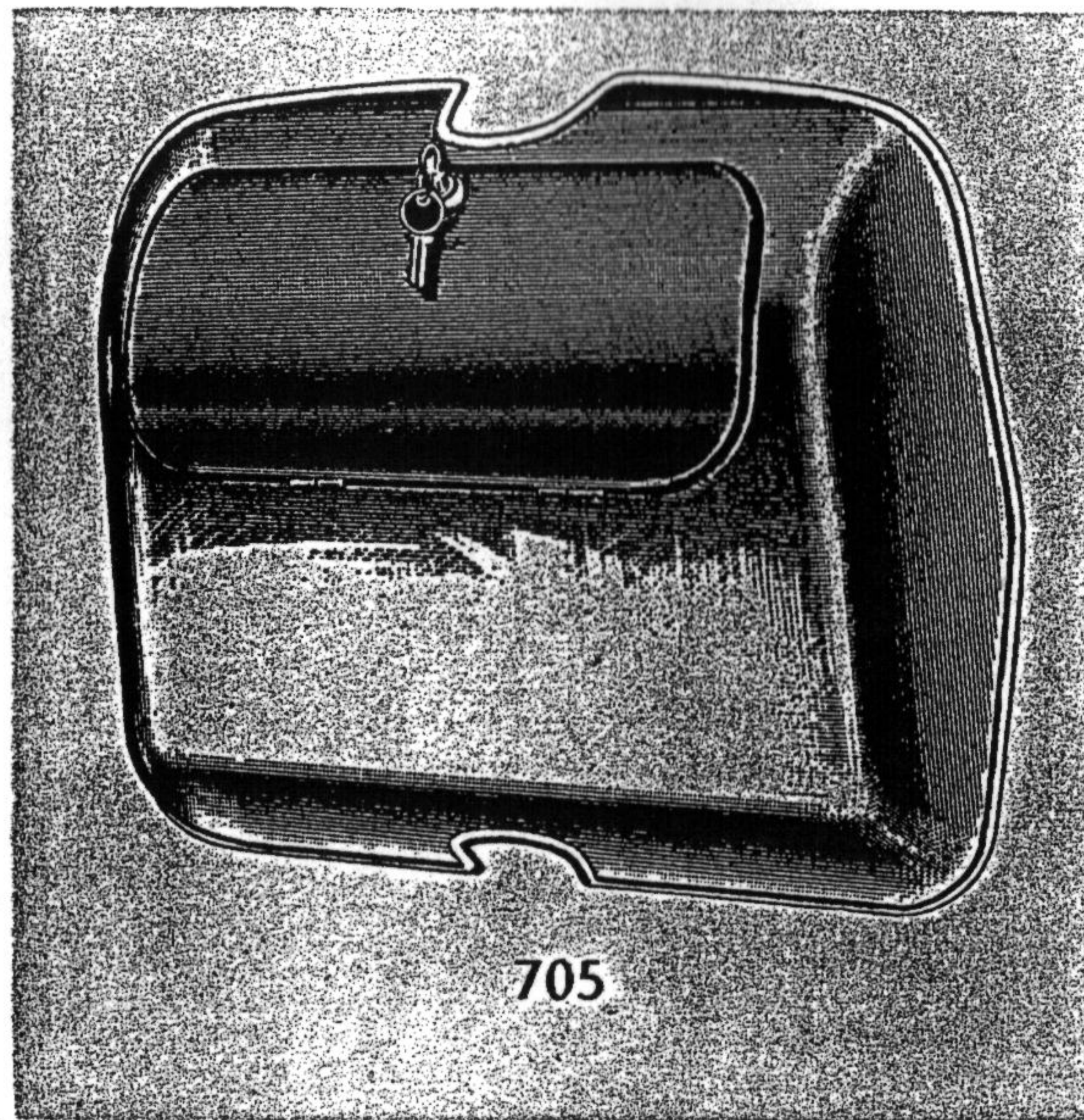

Sacoches

1035 - Sacoche de Tablier avant Cuir 1^{re} Qualité

1035 A - Sacoche de Tablier avant Cuir 1^{re} Qualité avec poche extérieure

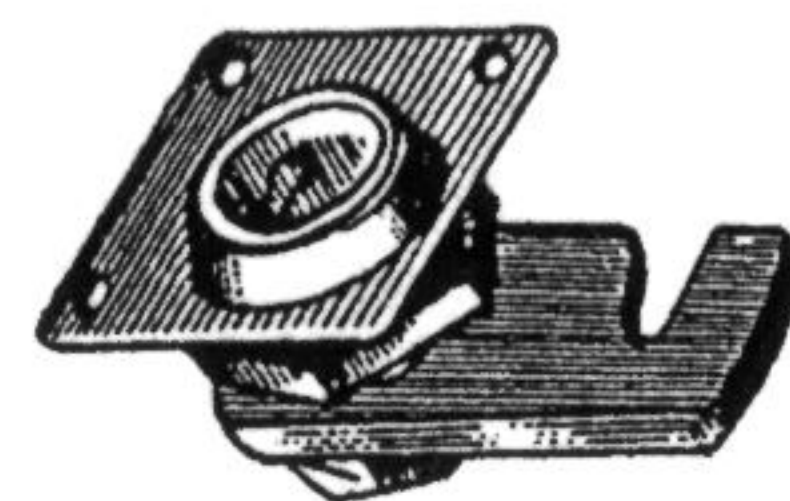
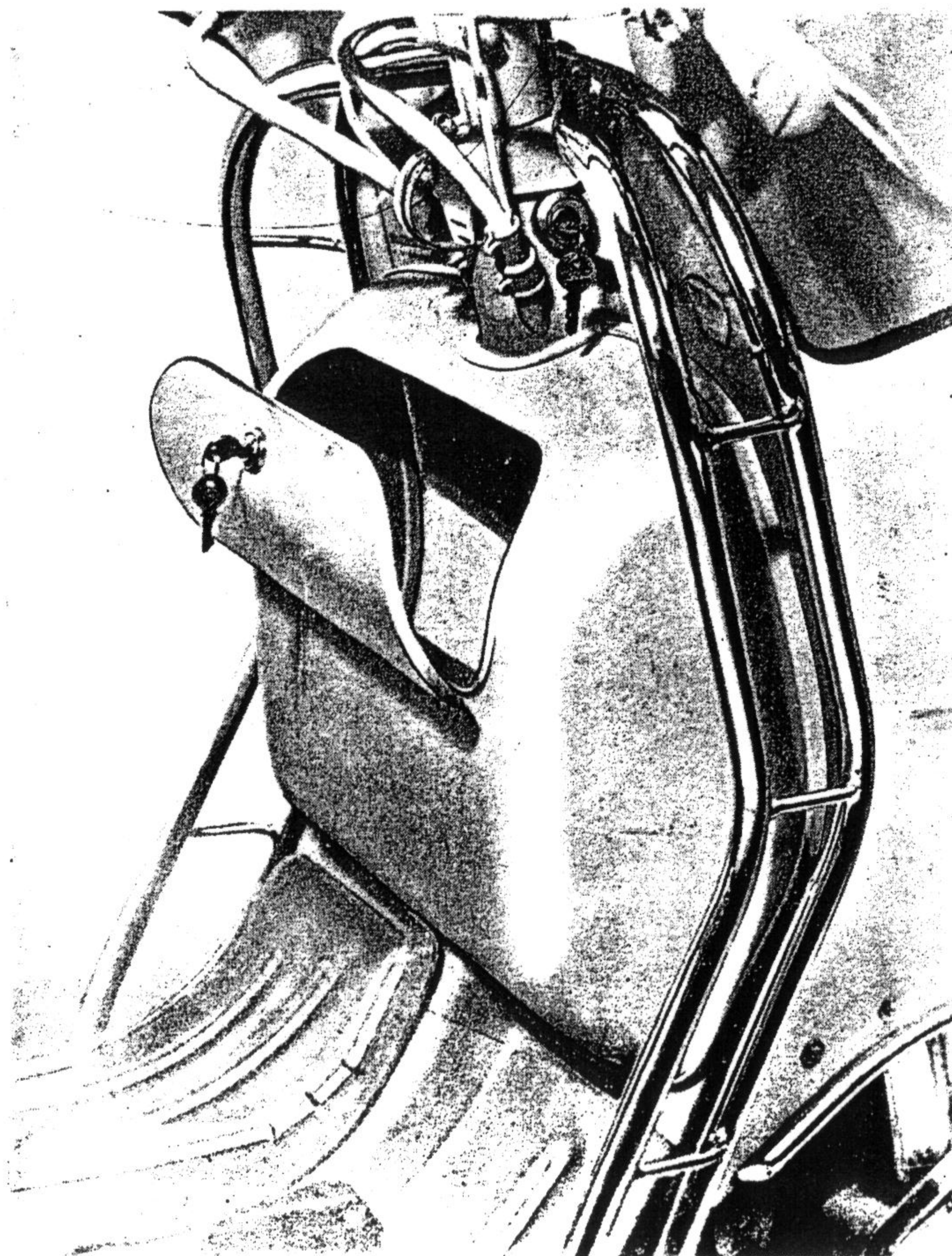

844 - Serrure de Coffre Ronis avec 2 clefs

908 - Serrure de Coffre à Couvercle Chromé



844 B- Serrure Antivol de Roue de Secours

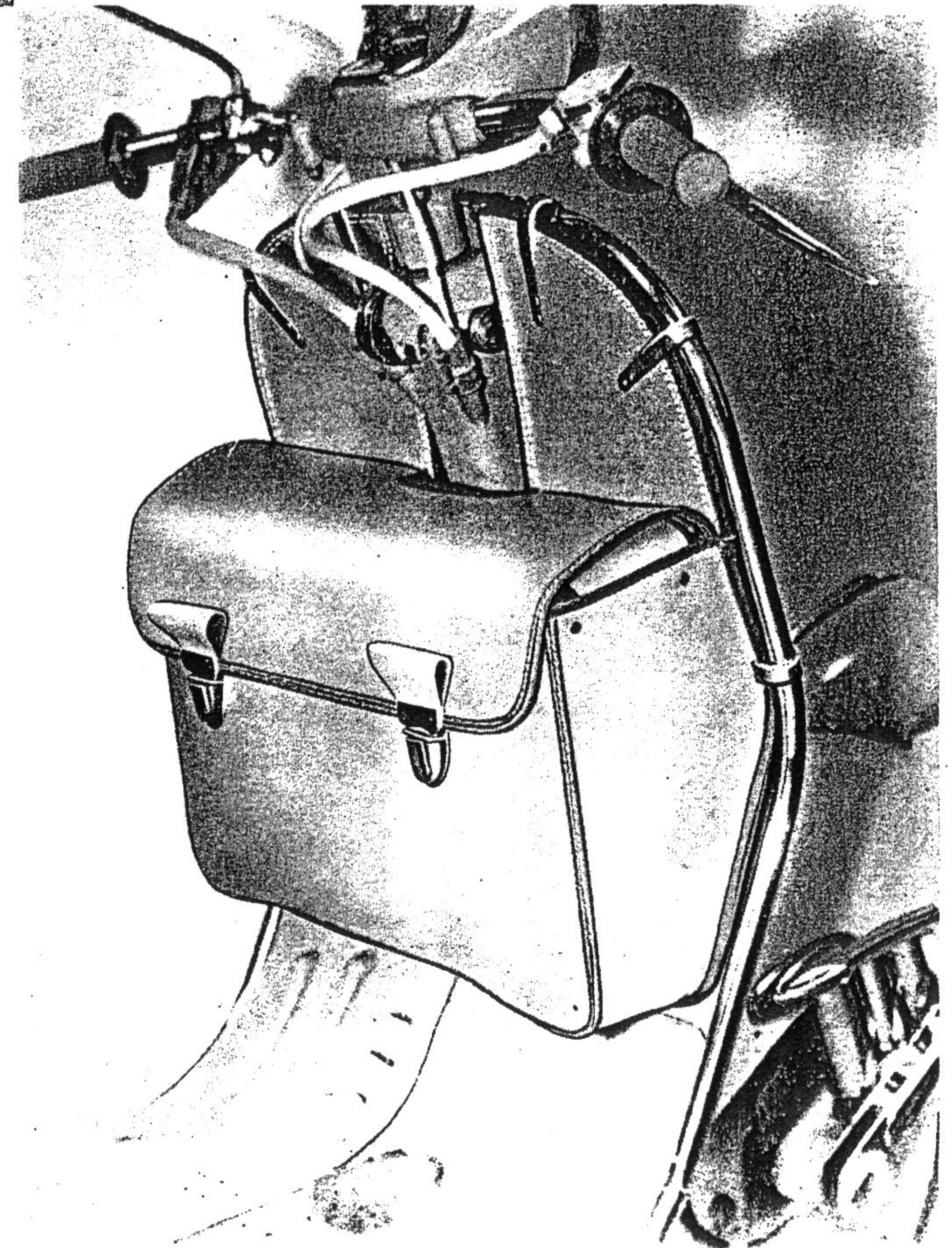

De la part de FAN DE SCOOTER

921 - Crochet
Porte-Serviette



921

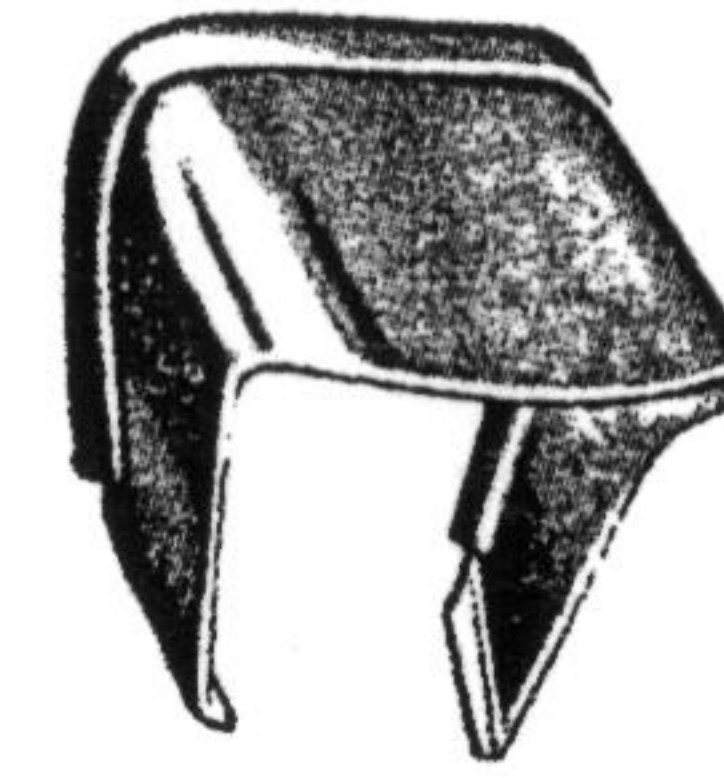

801 - Visière de Compteur Chromée

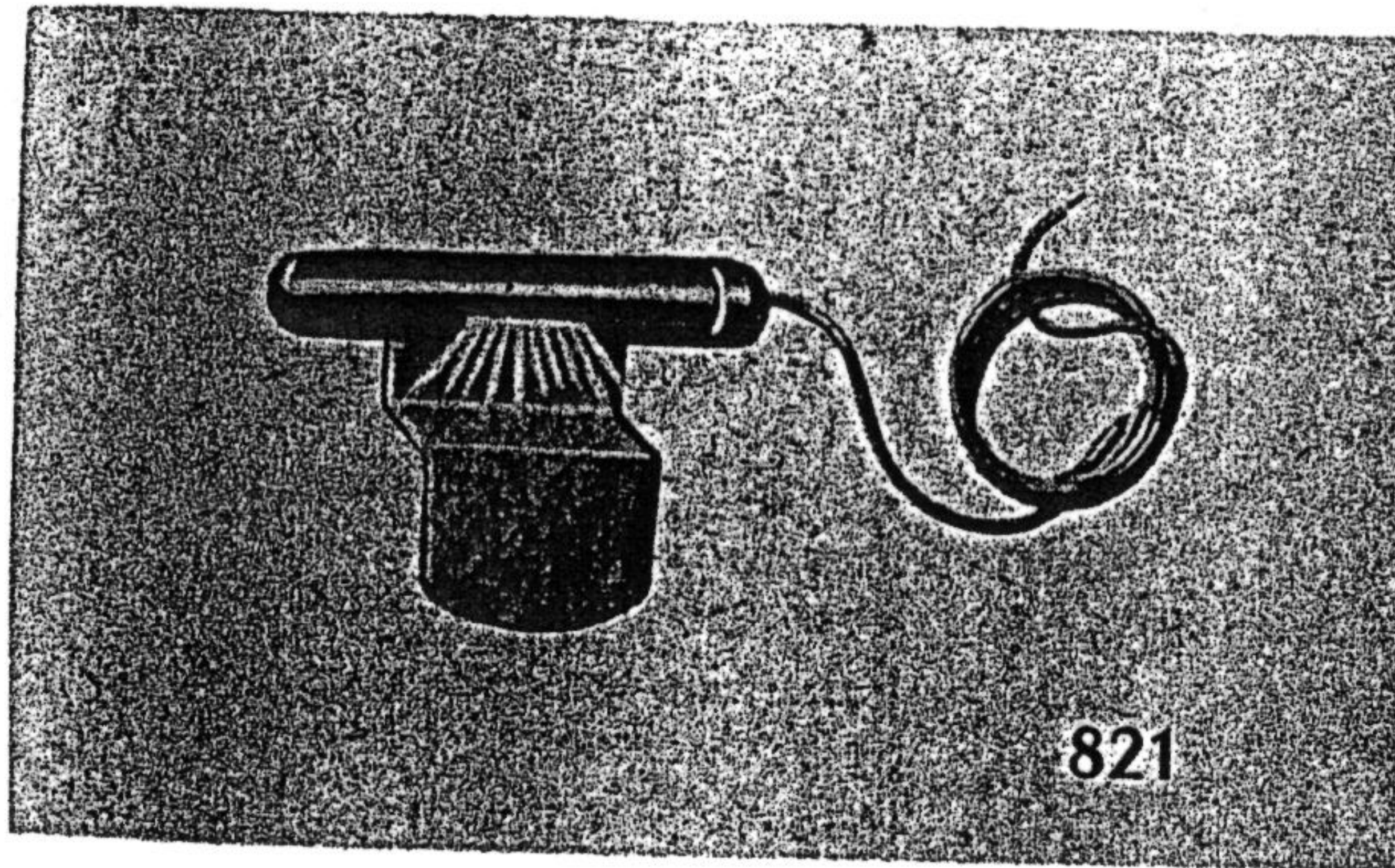

821

821 - Lampe d'éclairage de
Compteur

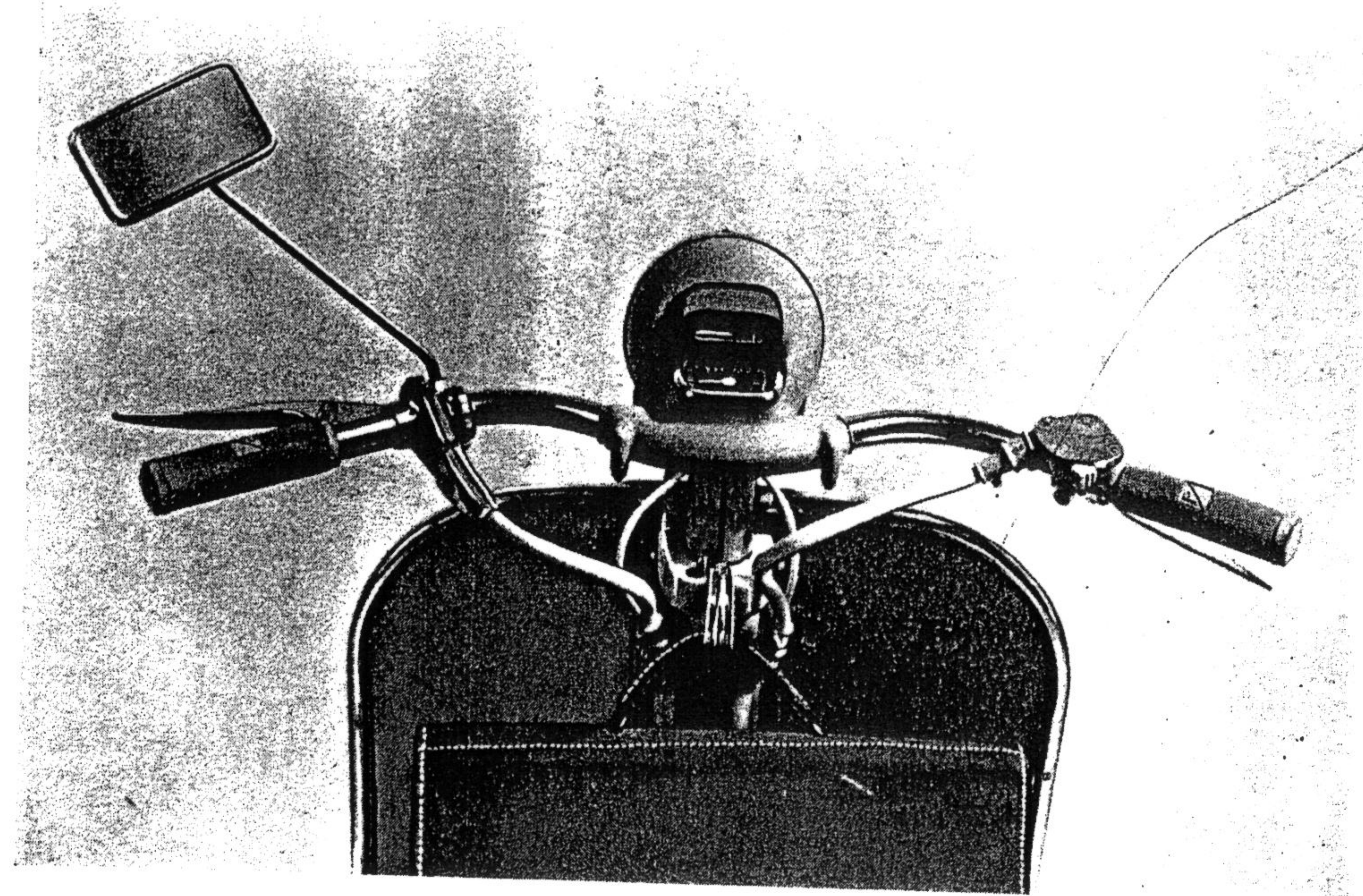

702 - Motif de Tablier avant avec Insigne Piaggio

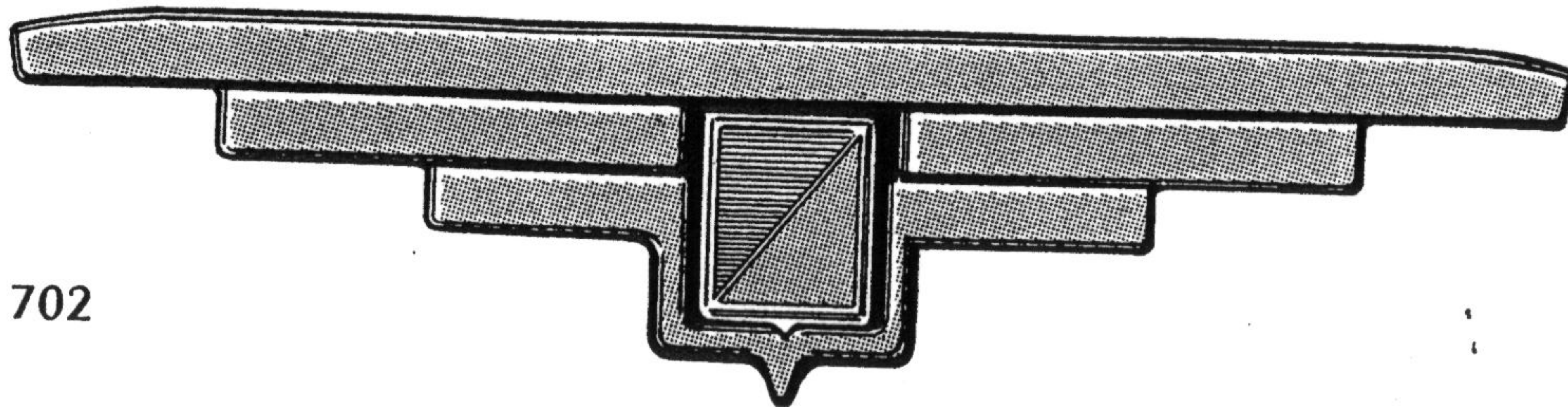

702

De la part de FAN DE SCOOTER



967 - Parasol noir pour Pare-Brise



833 - Pare-Brise 20/10, non entouré, grand luxe

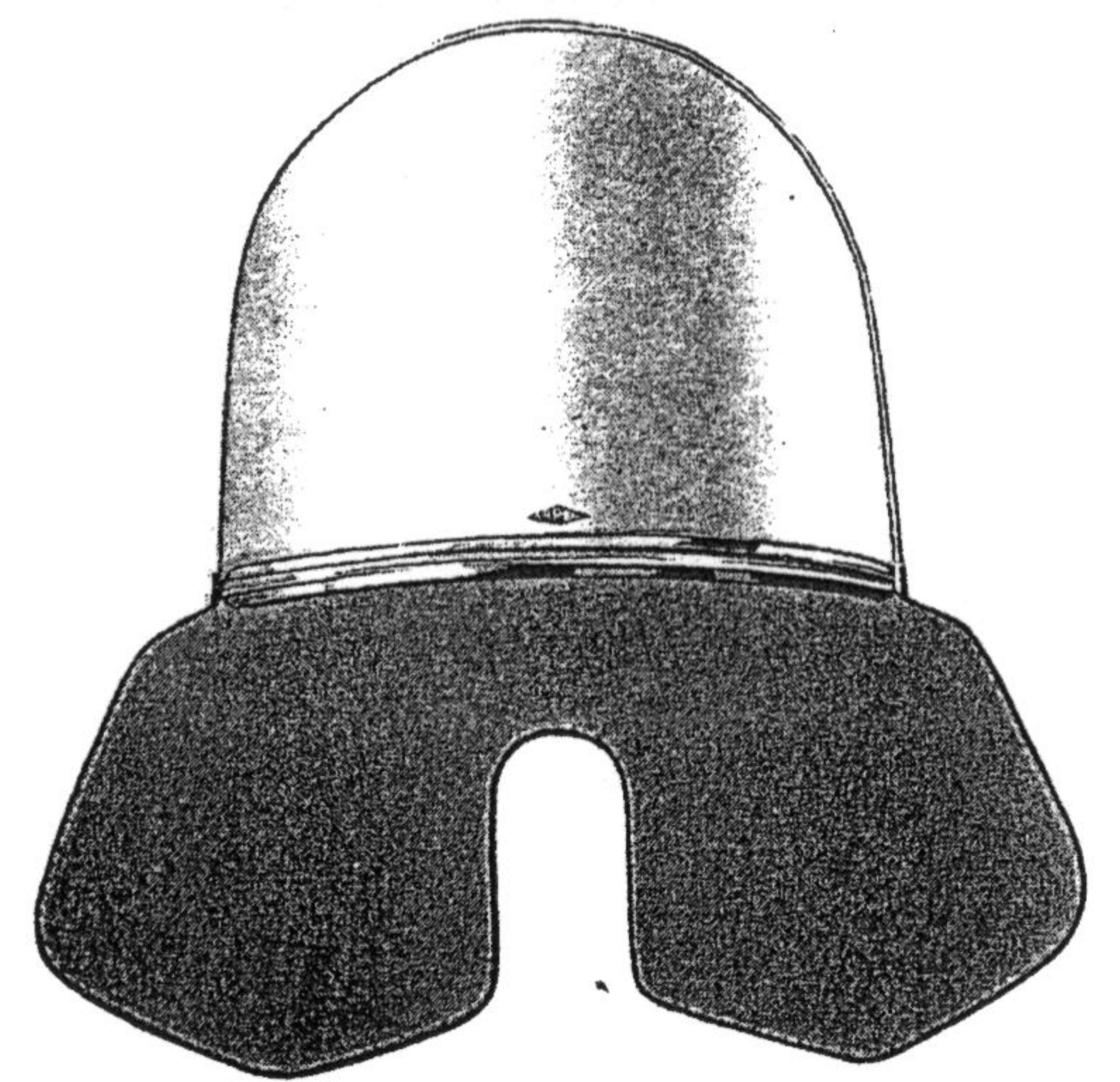

890 - Pare-Brise entouré plastique luxe, tiges chromées

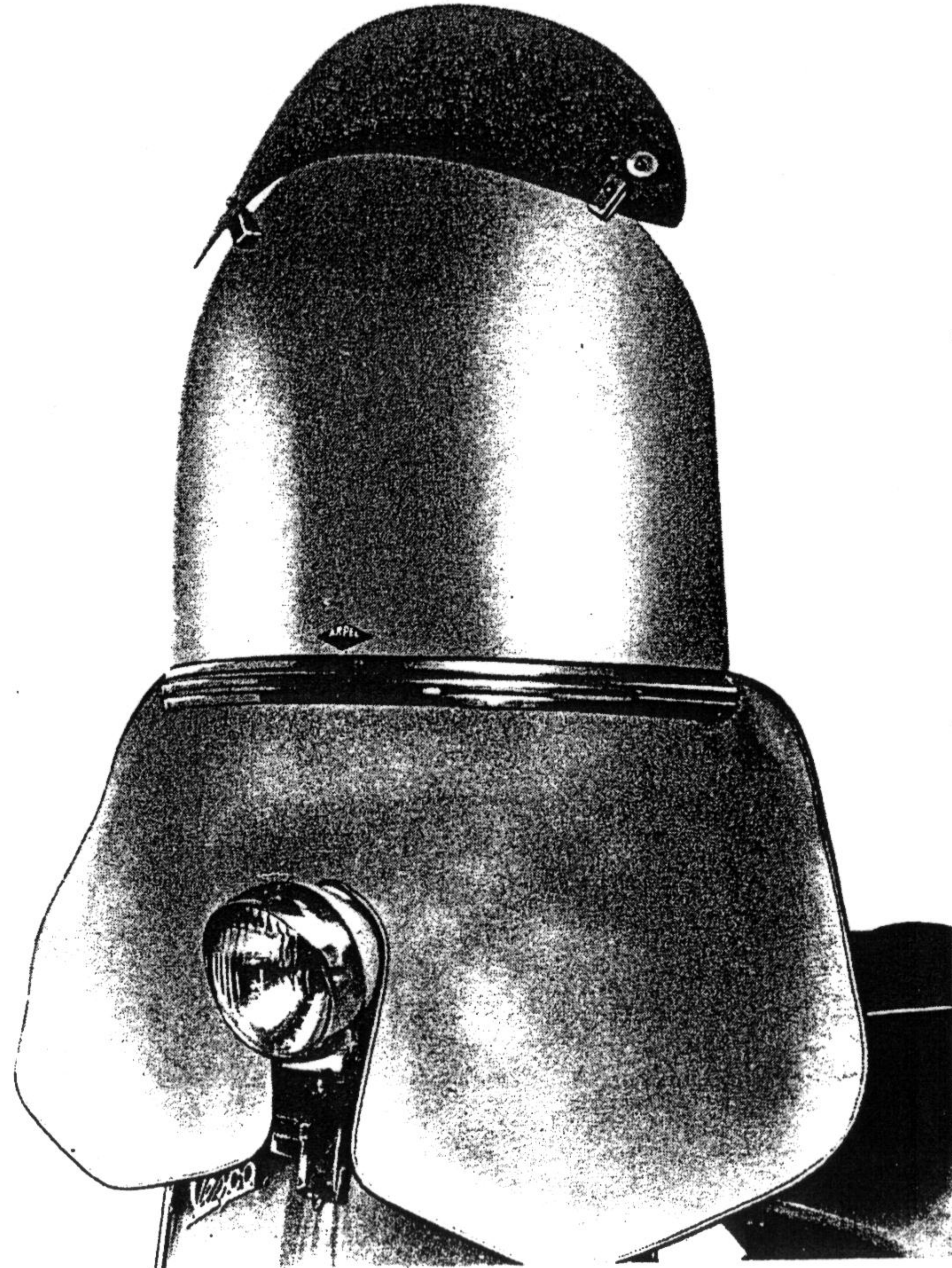

Pare - Brise

975 - Toit protecteur pour Pare-Brise (920/920 A/920 B)

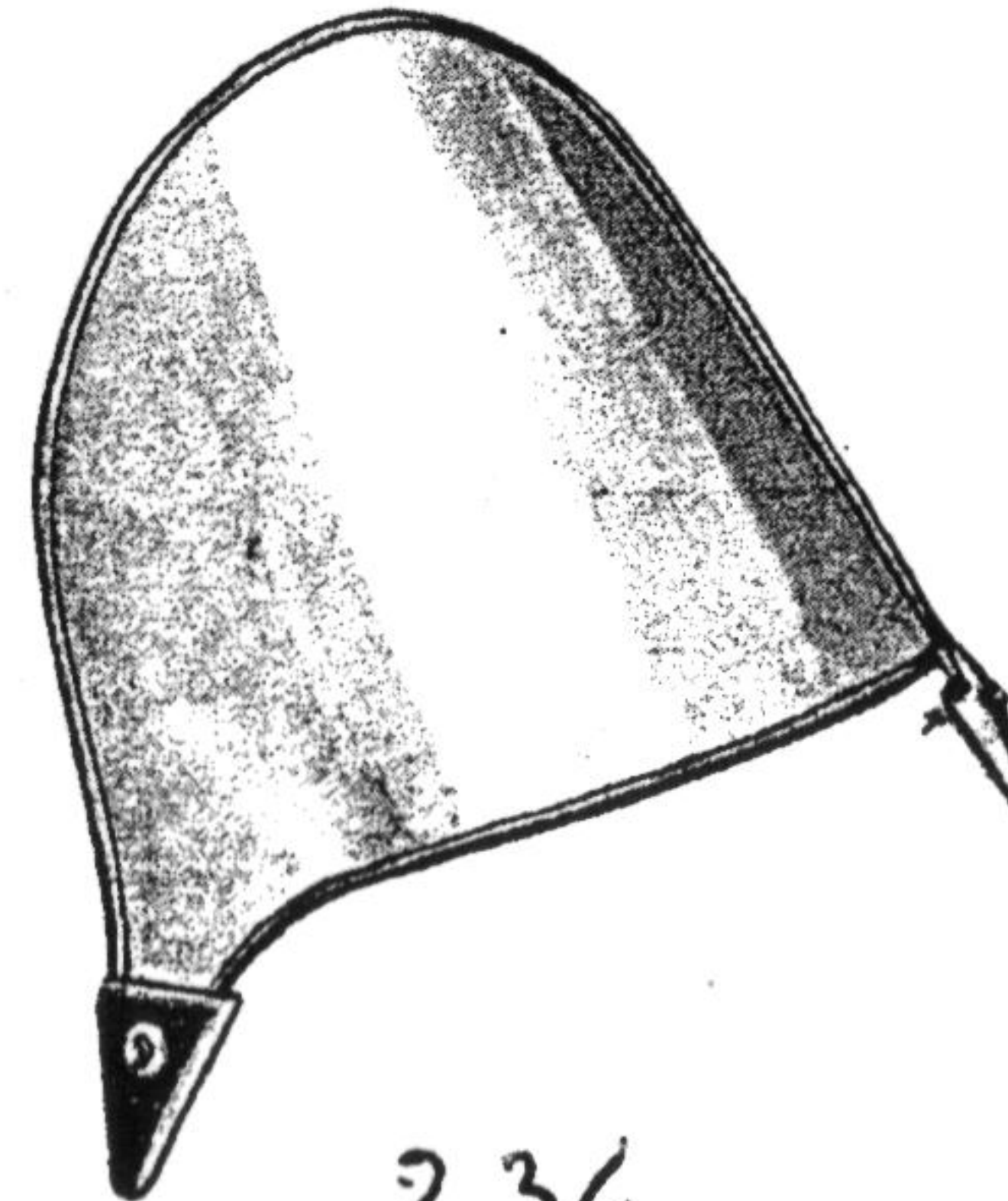

234

*Pare - Soleil **

- 920A - Pare-Brise entouré métal, Grand Tourisme, tiges chromées
- 920 - Pare-Brise entouré métal, Luxe, tiges chromées
- 920B - Pare-Brise entouré métal, Sport, tiges cadmiées

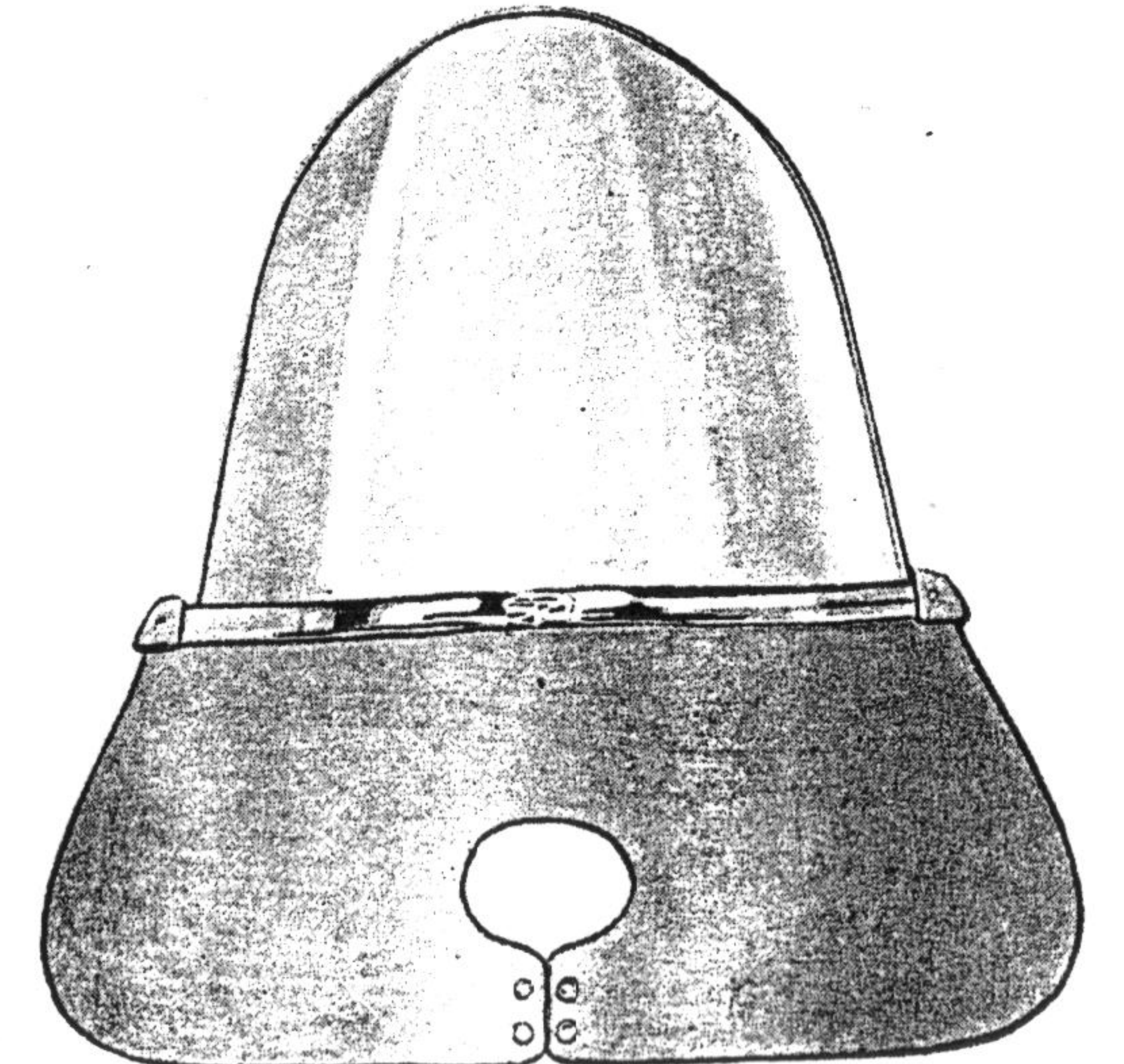

De la part de FAN DE SCOOTER



903 - Carène de Phare Type
Mistral

* Pare - Insectes

- 920 A - 975 - Pare-Brise entouré métal, Grand Tourisme, formant cabine, tiges chromées
- 920 - 975 - Pare - Brise entouré métal, Luxe, formant cabine, tiges chromées
- 920 B - 975 - Pare - Brise entouré métal, Sport, formant cabine, tiges cadmiées

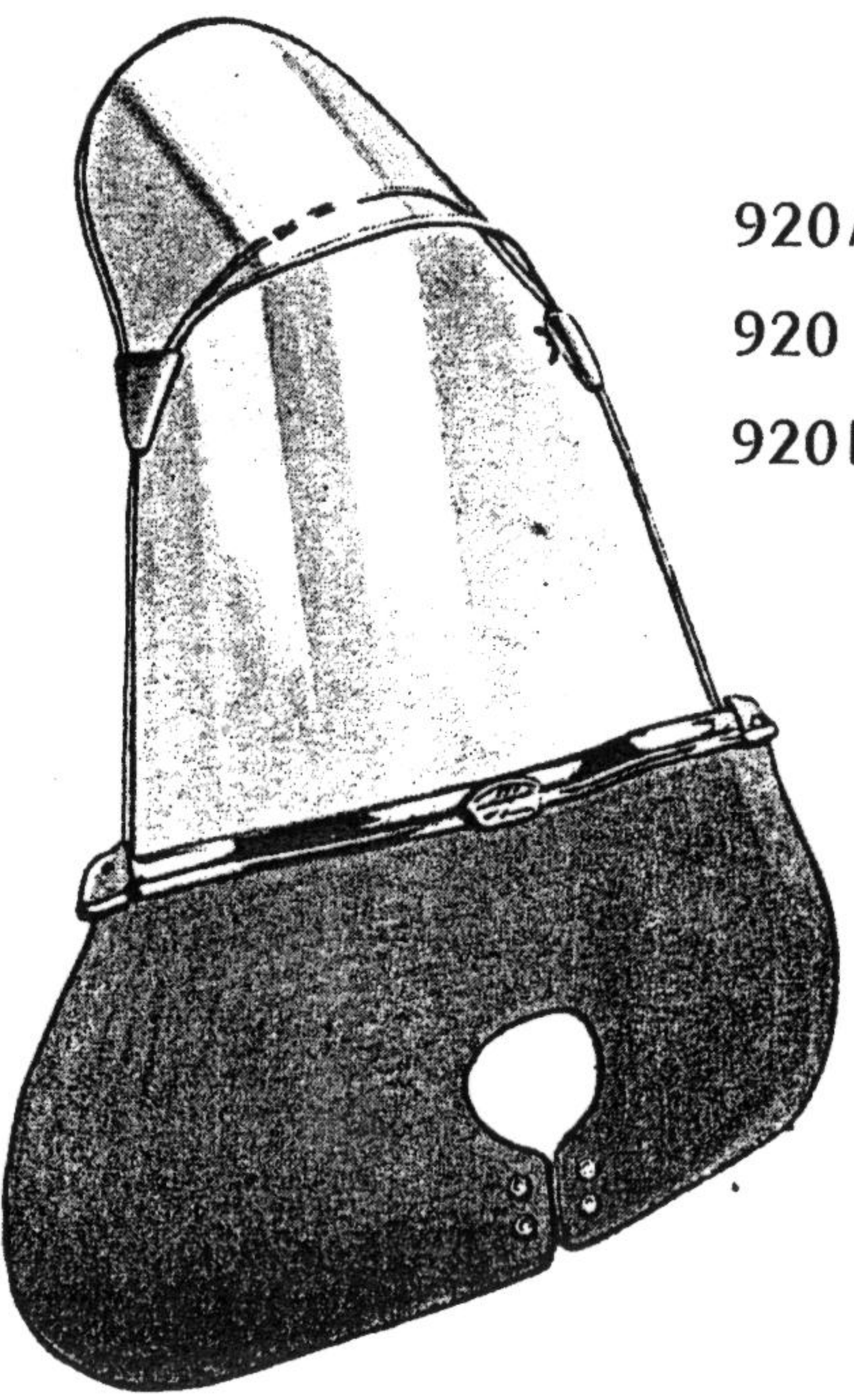
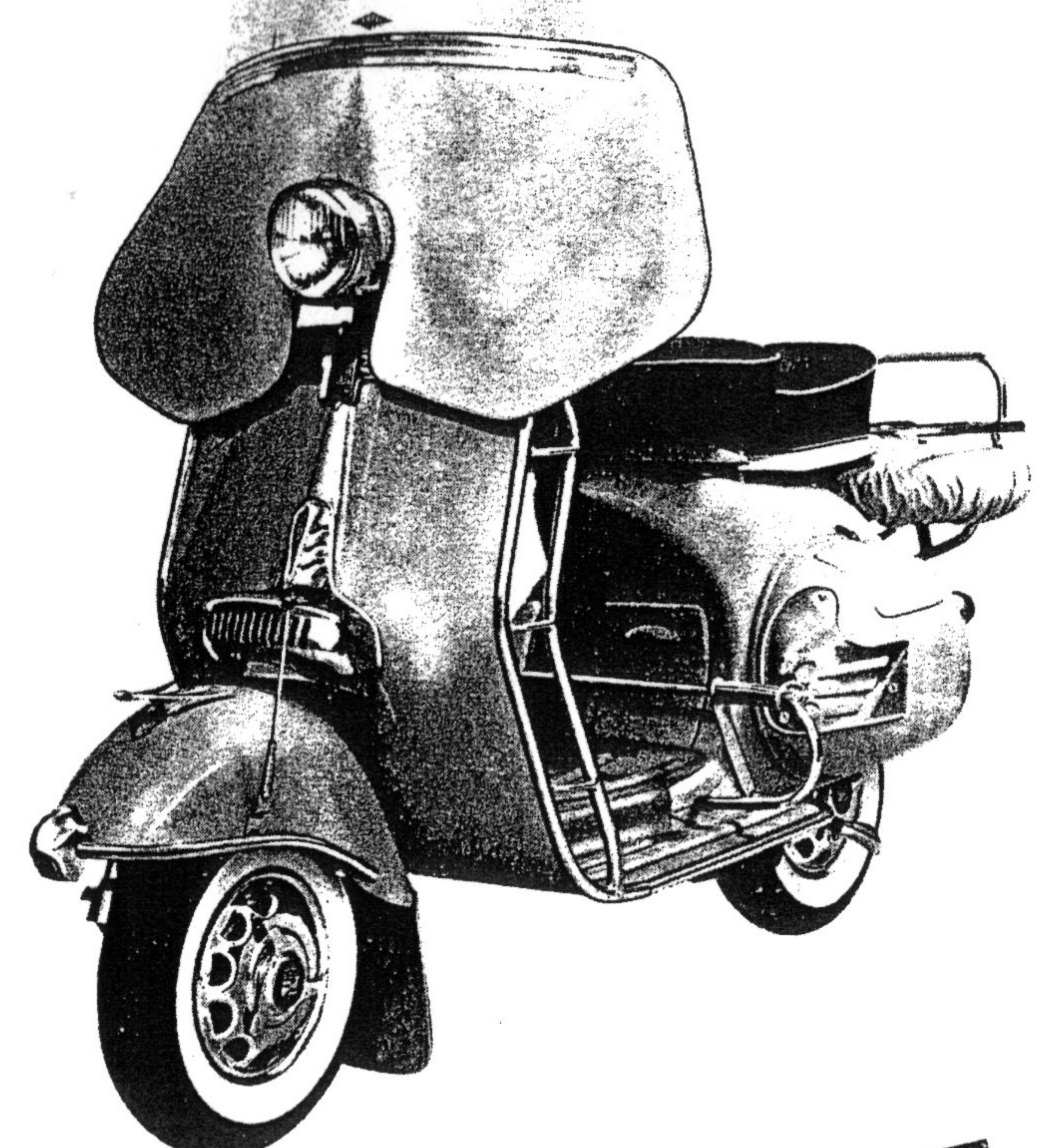

920A - 975
920 - 975
920B - 975

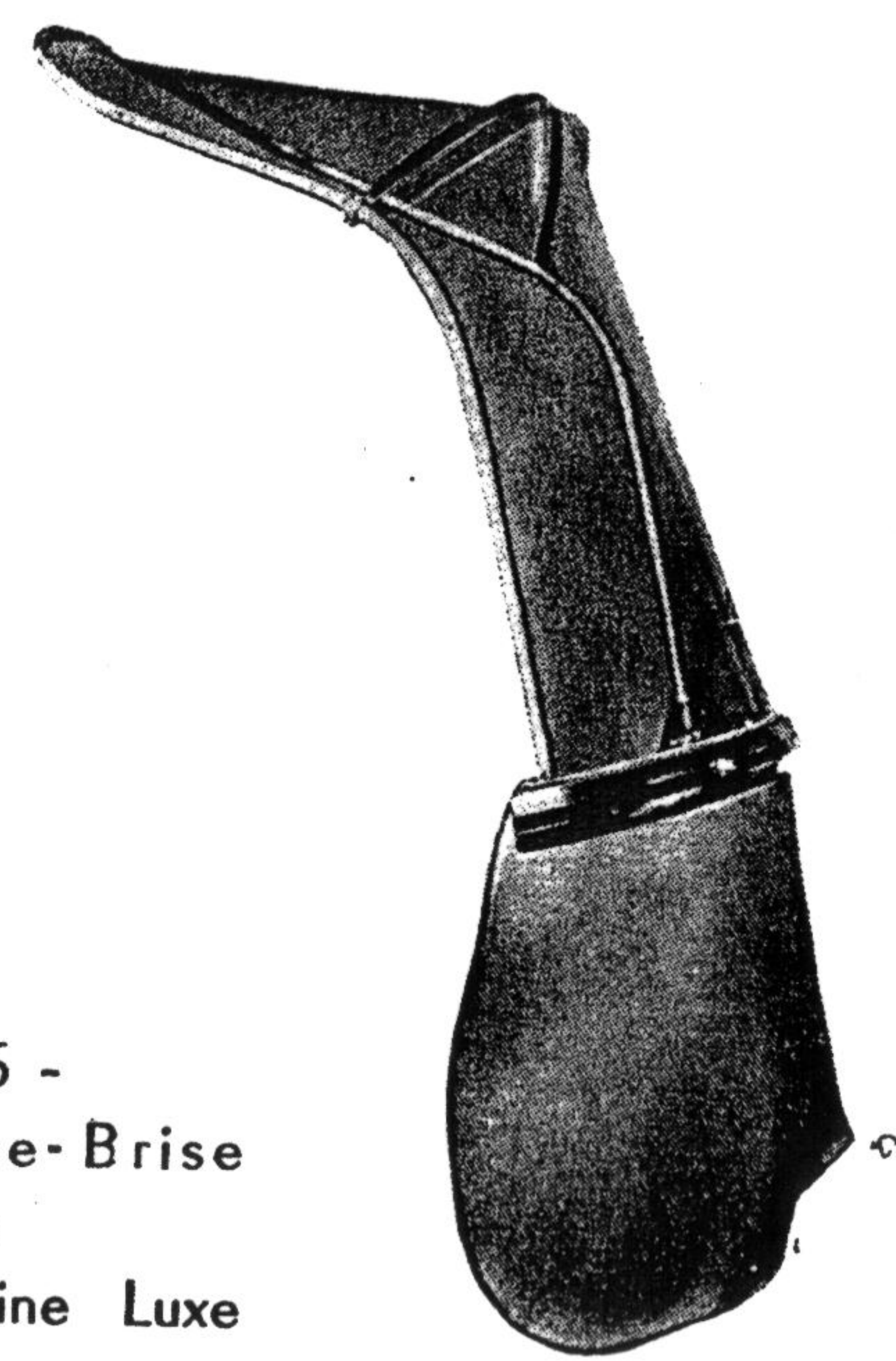

906 -
Pare-Brise
type
Cabine Luxe

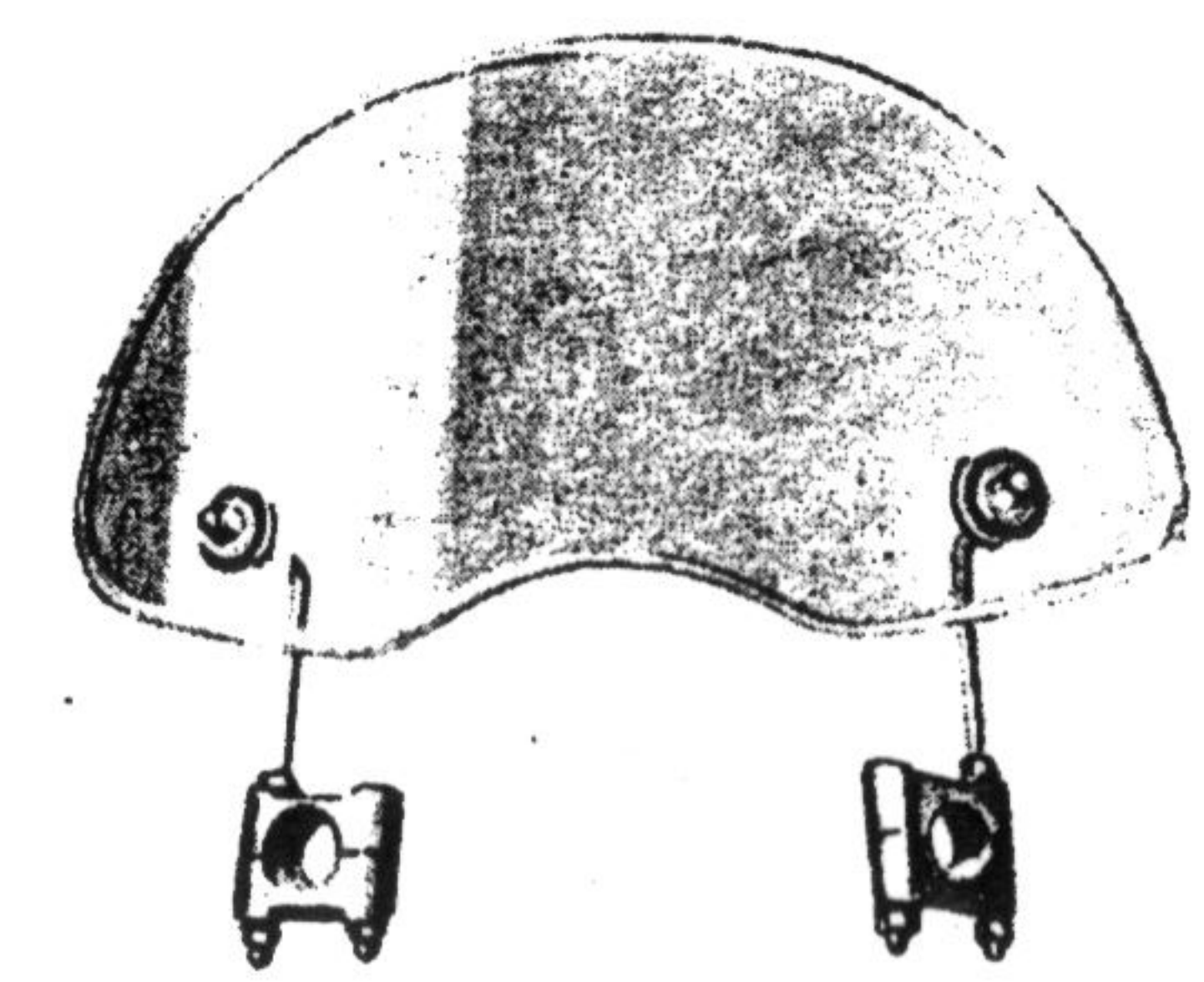

790 - Pare-Insectes Luxe,
Vert ou Rouge

860 - Pare-Insectes Grand
Luxe, Vert ou Orange

12
**De la part de
FAN DE SCOOTER**

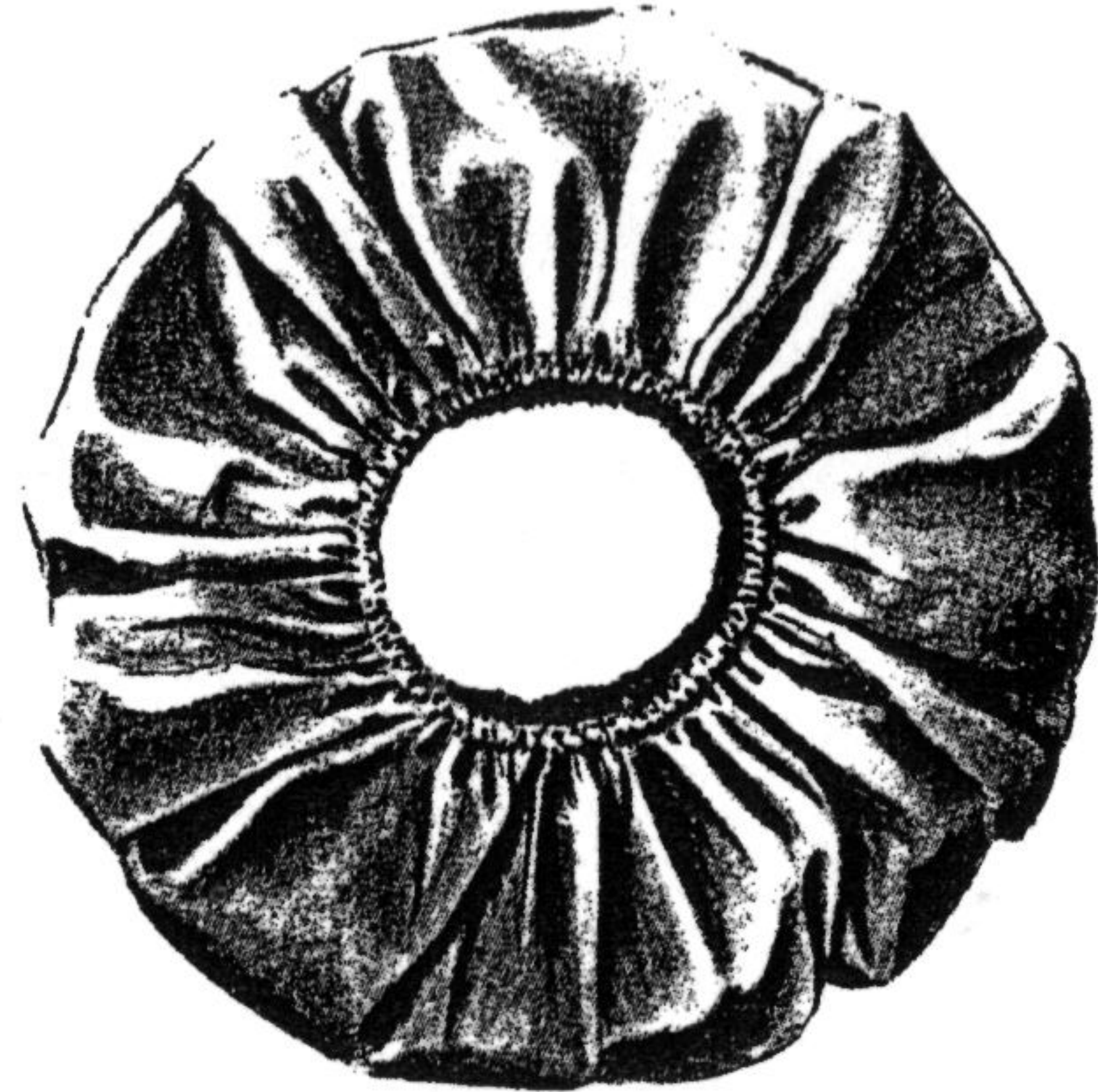

832
933

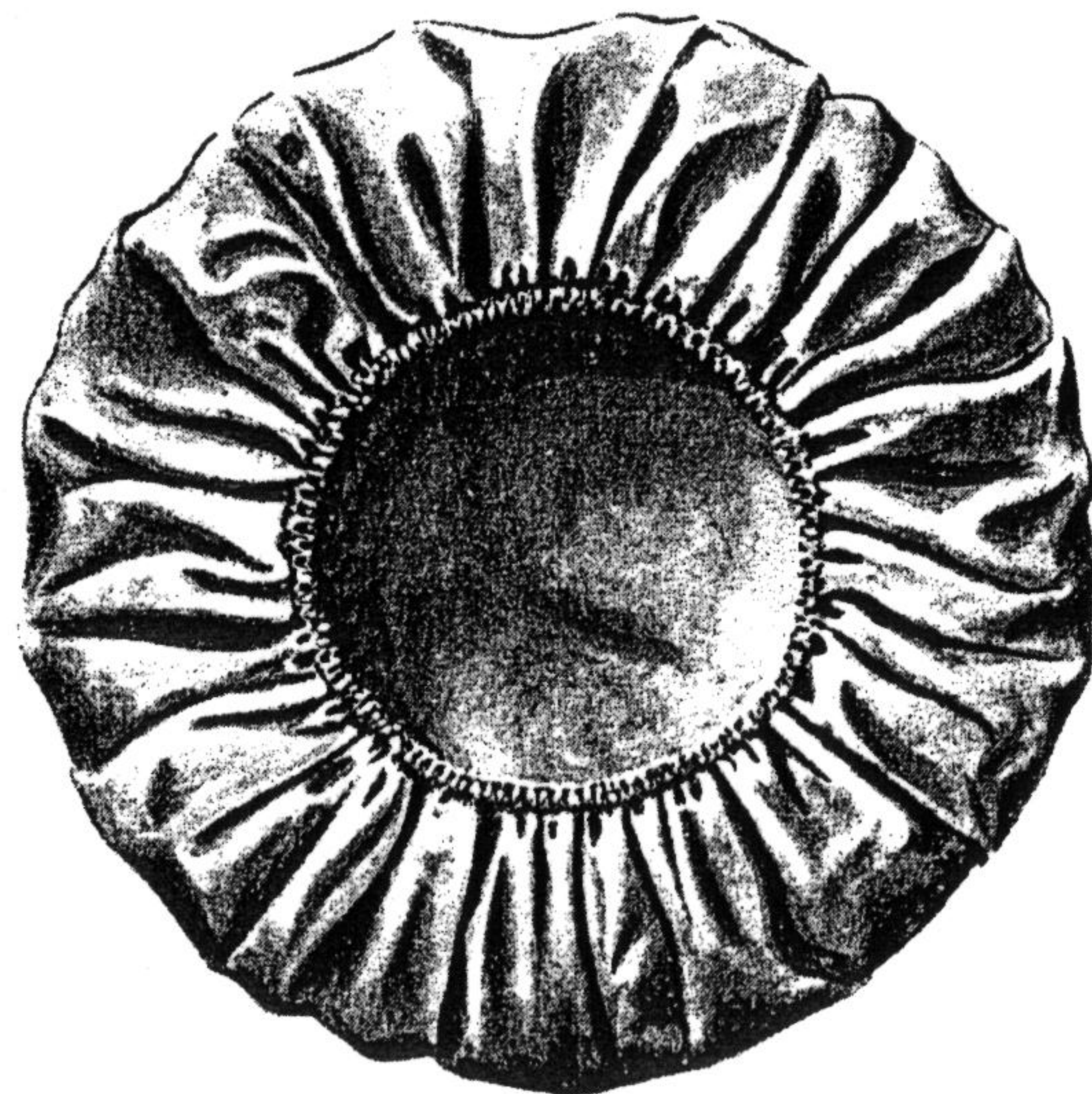

774

Housses

- 832 - Housse de Roue, plastique doublée. Couleur vert clair vert foncé et gris 56
- 933 - Housse de Roue, plastique non doublée
- 774 - Housse de Roue, disque plastique doublée. Couleur vert clair, vert foncé et gris 56

773 - Housse Enveloppante de Scooter sans Pare-Brise

773A - Housse Enveloppante de Scooter avec Pare-Brise

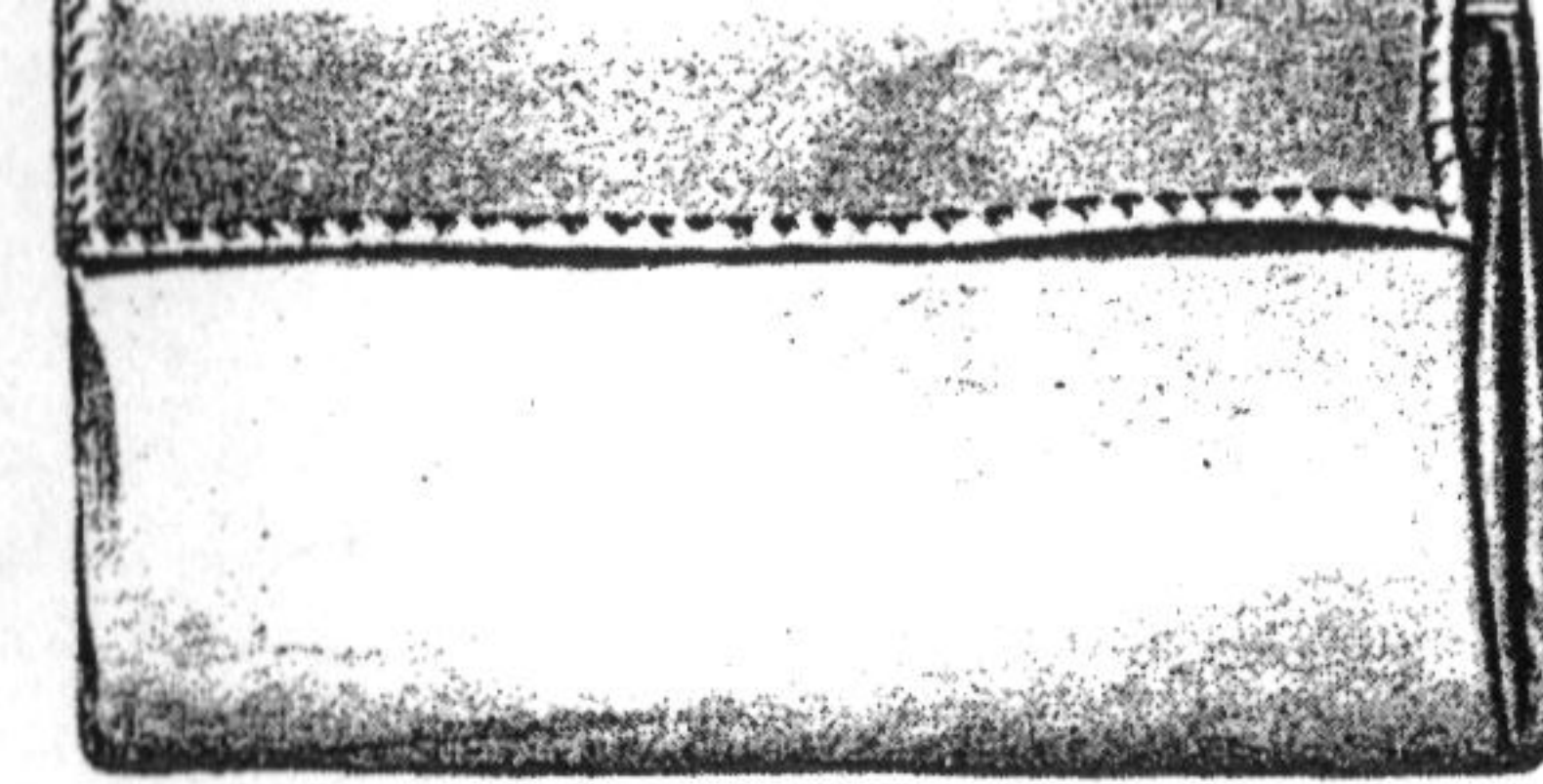

773

773 A

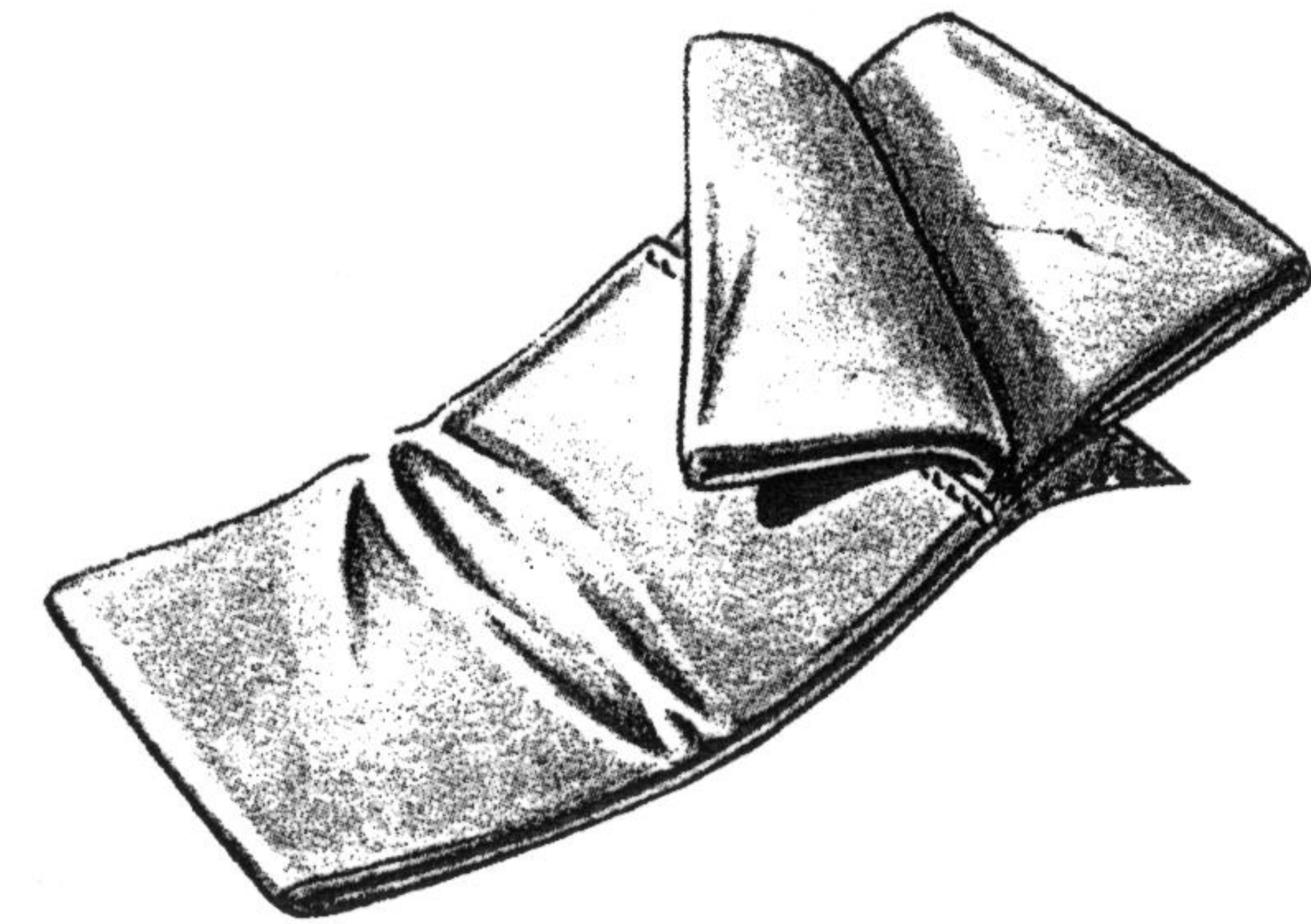

773

773 A

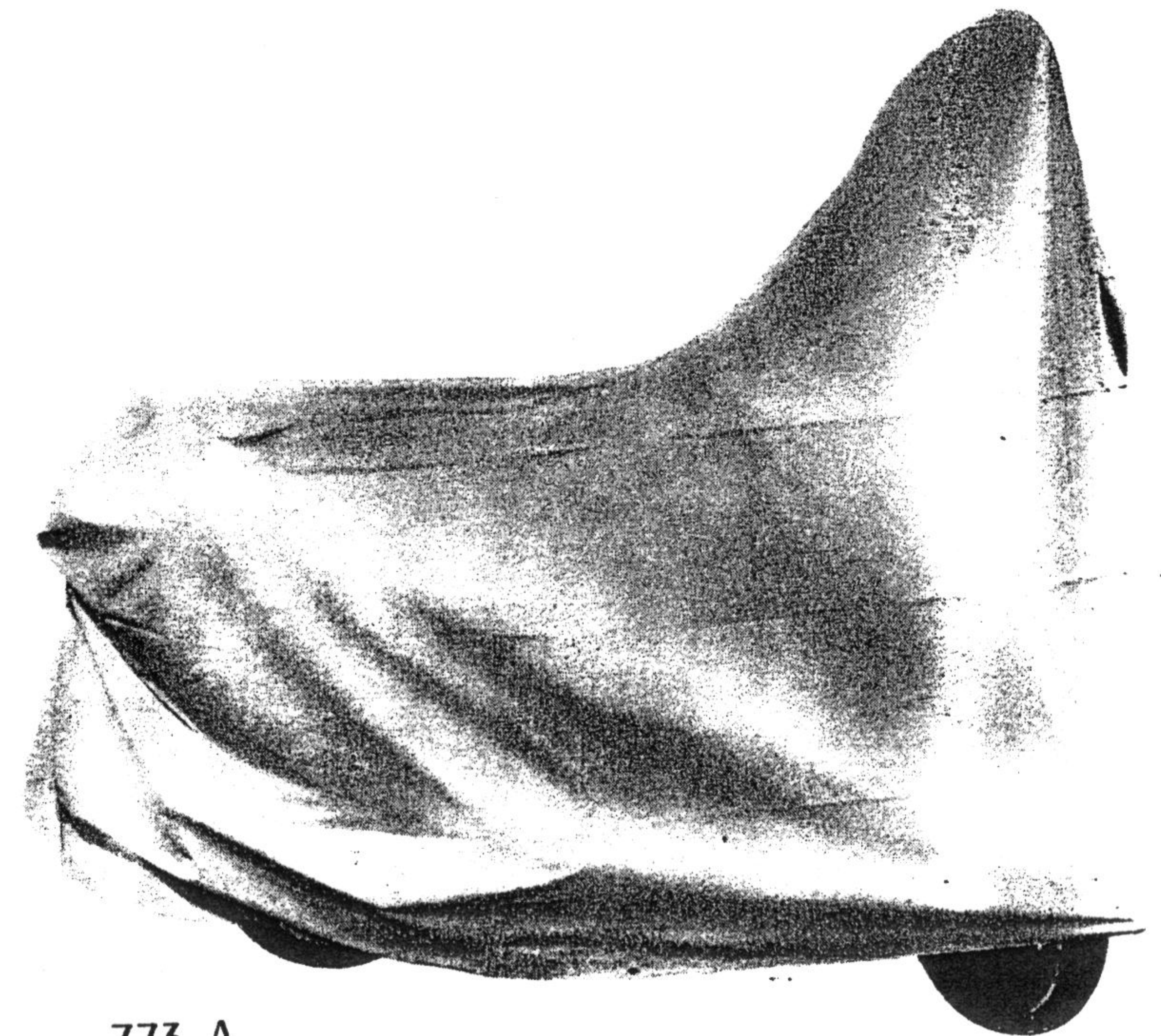

773 A

**De la part de
FAN DE SCOOTER**

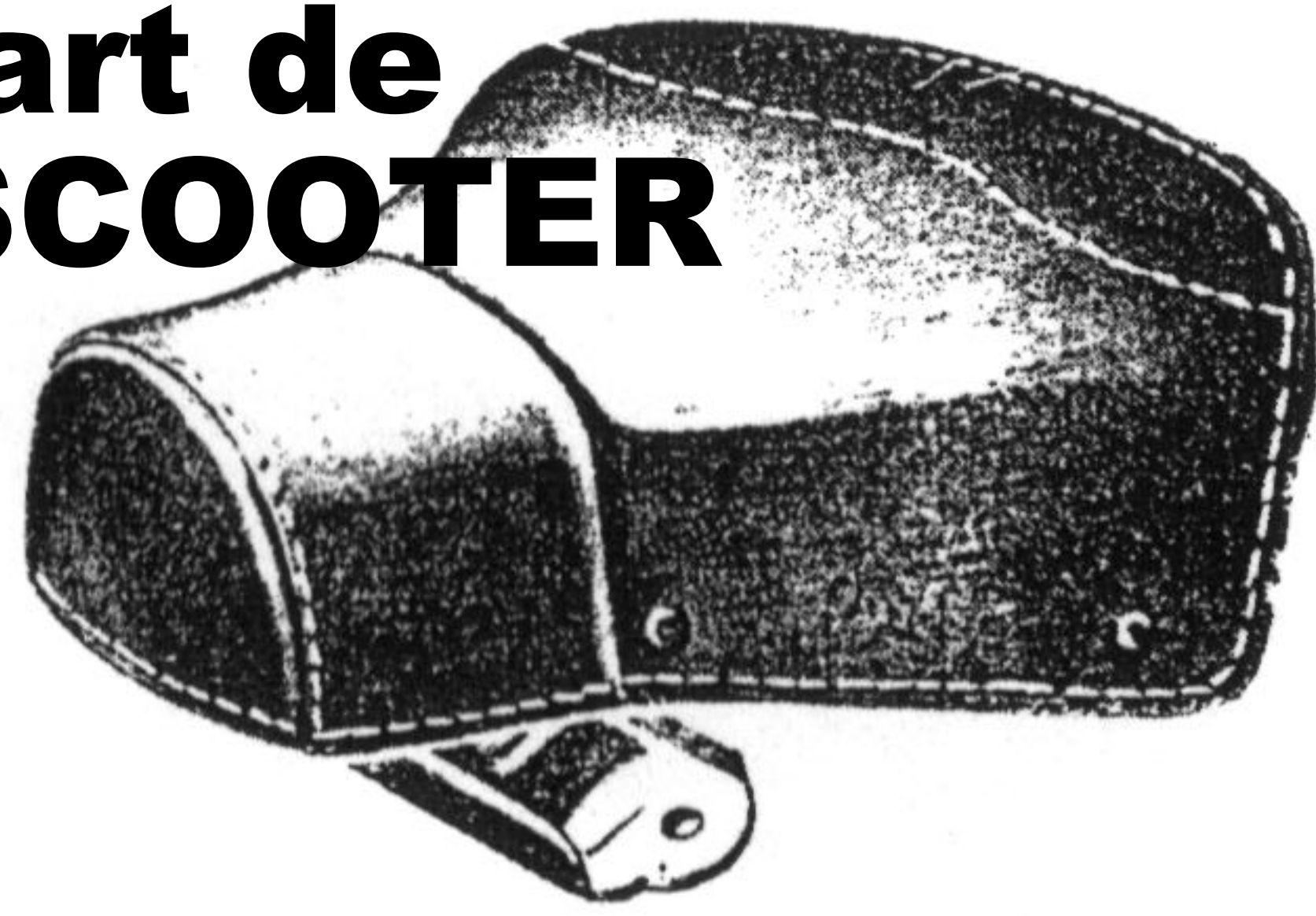

849

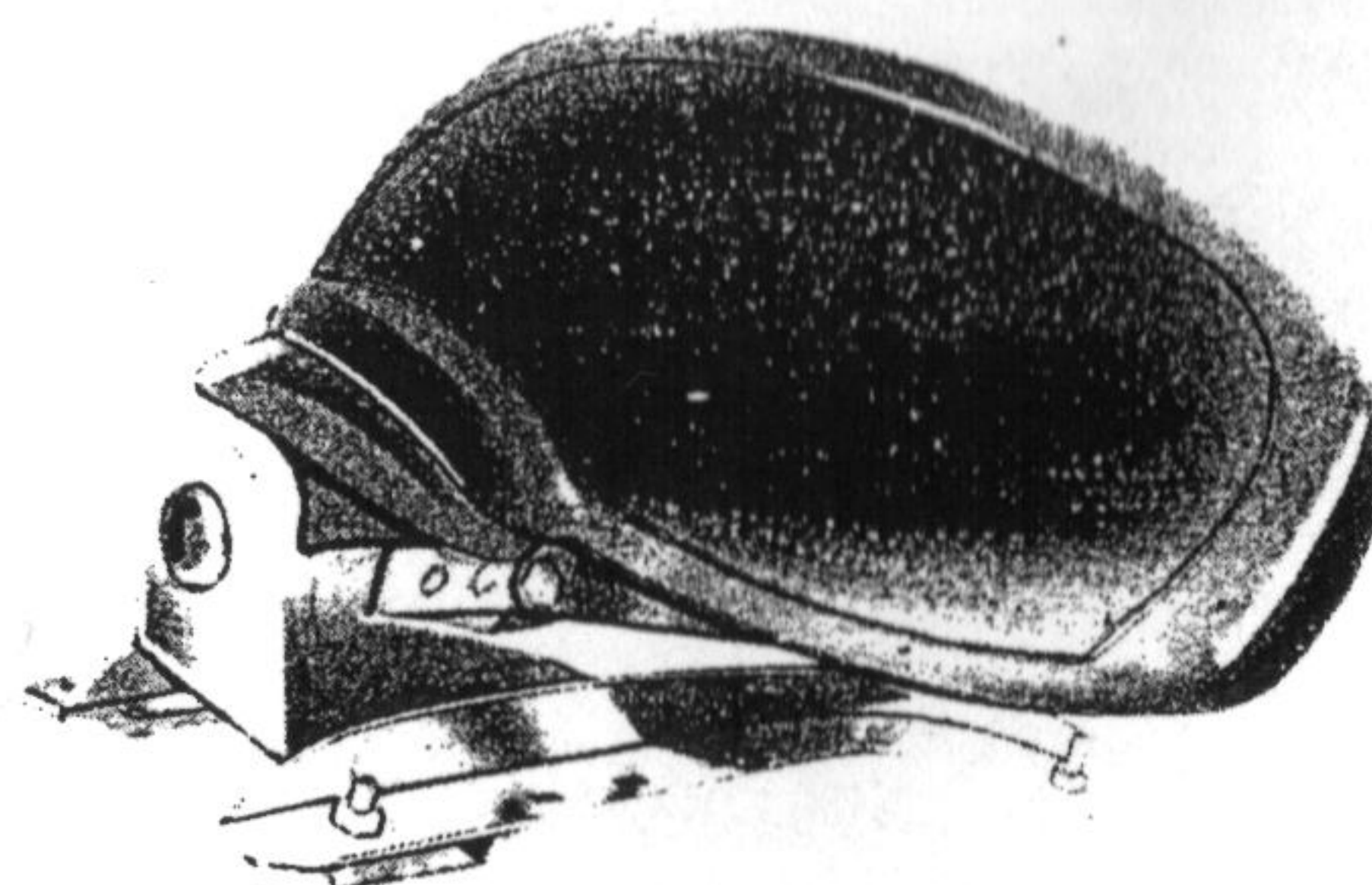

848

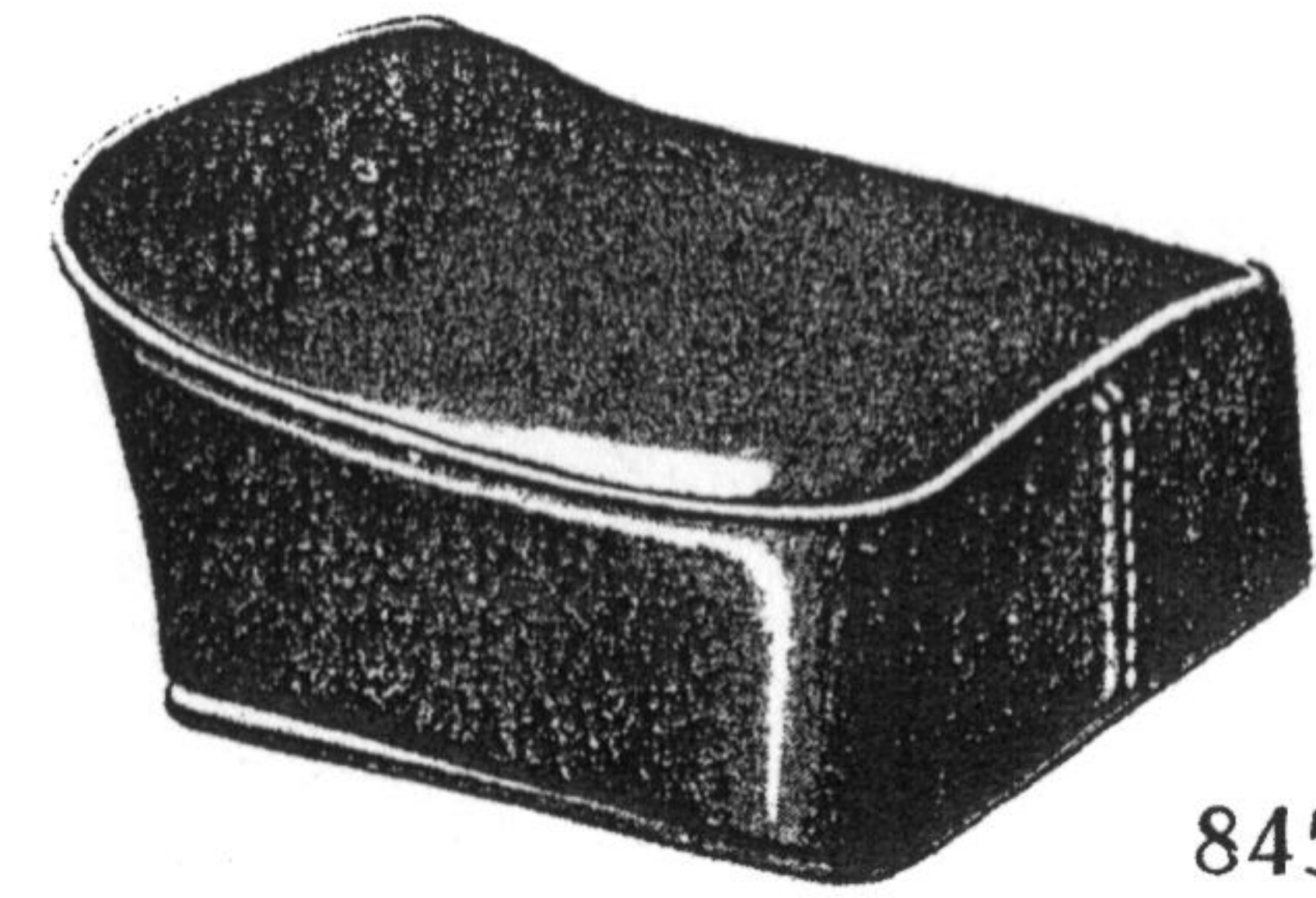

845

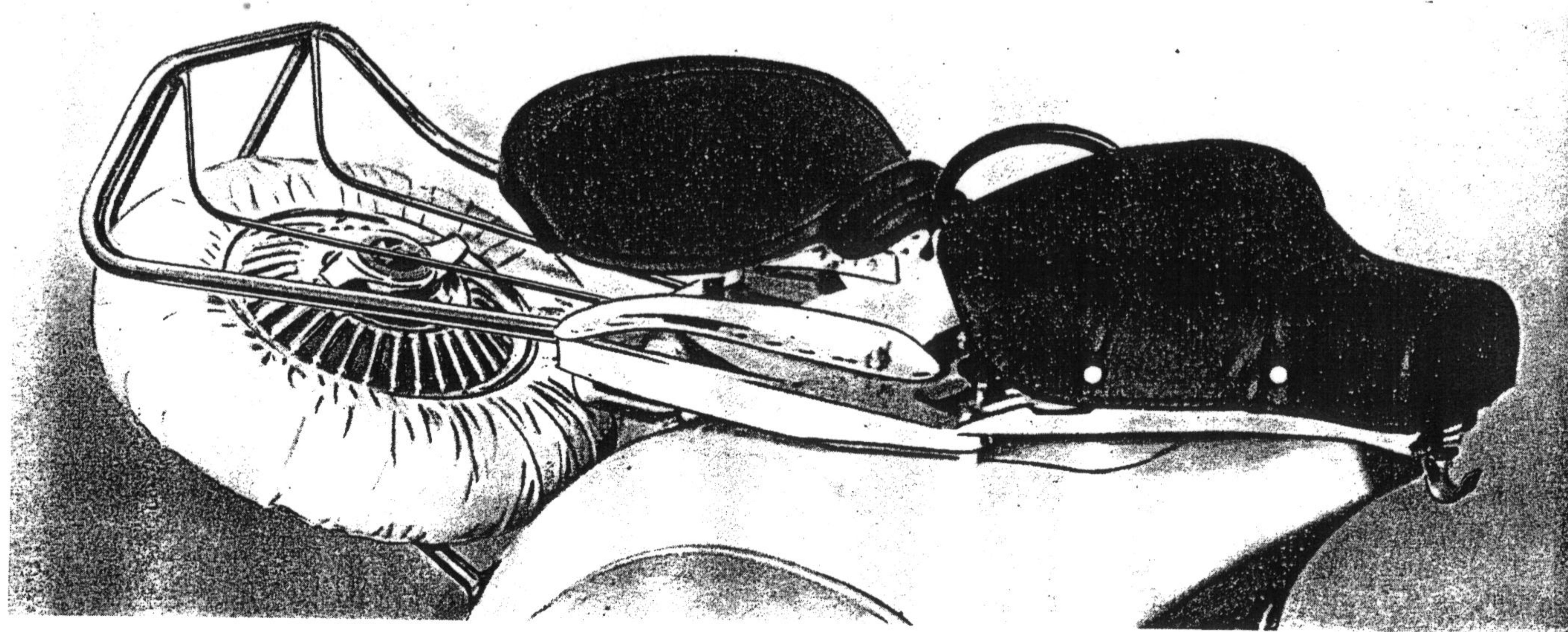

Selles

- 849 - Selle Arrière à Ressorts
Identique à la Selle avant
- 848 - Tand Sad "MURCIA"
Grand Modèle Luxe

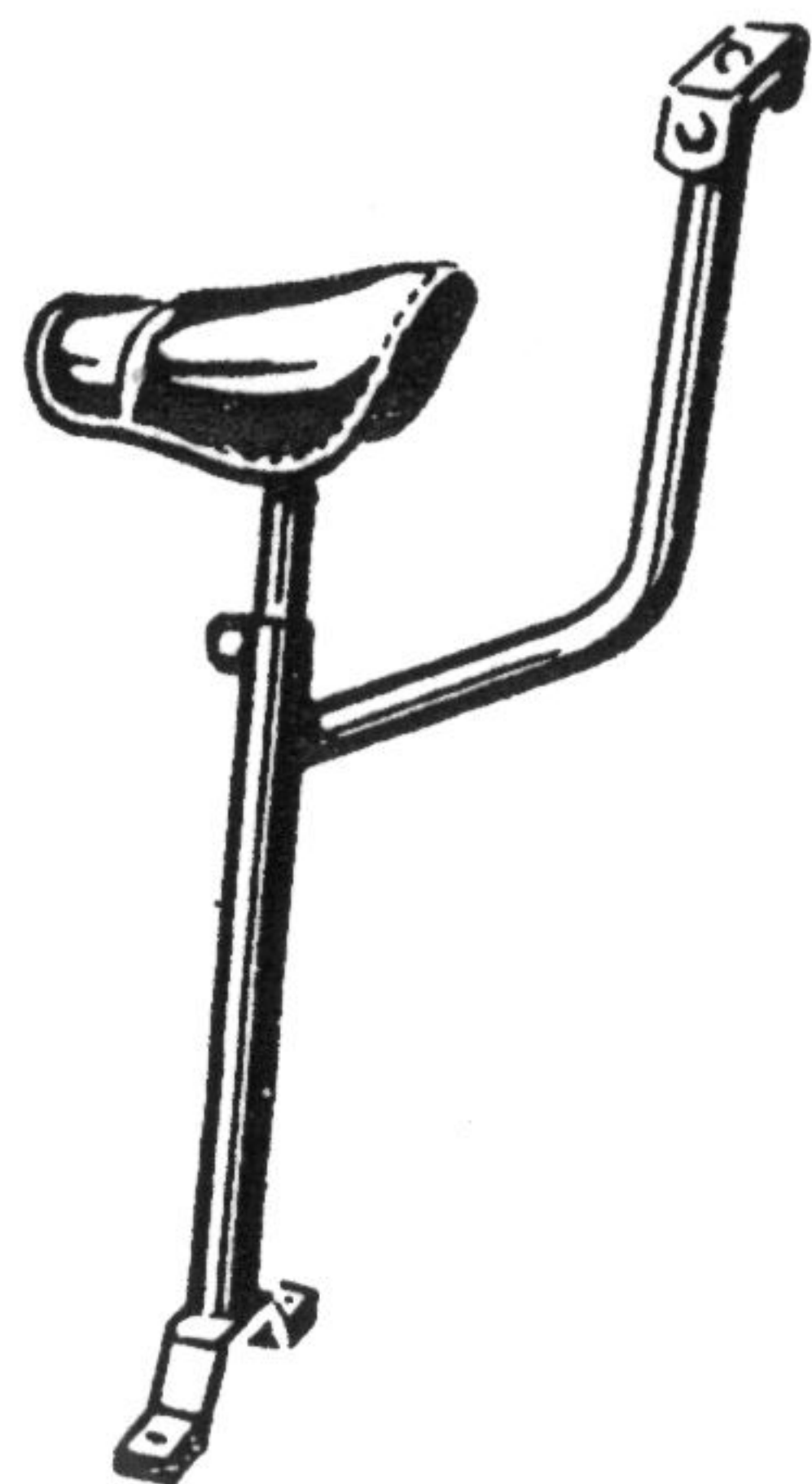

976 - Dossier 2^e passager

986 - Siège « BABY »

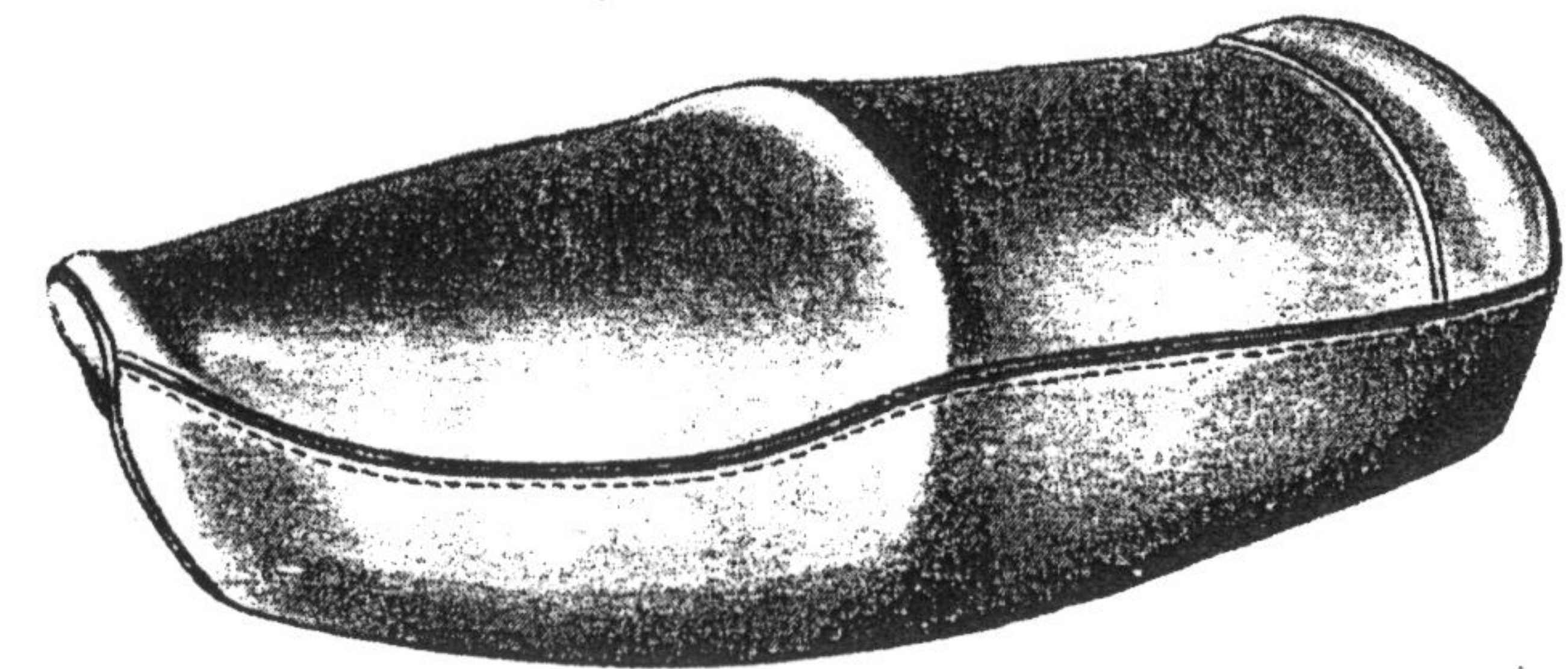
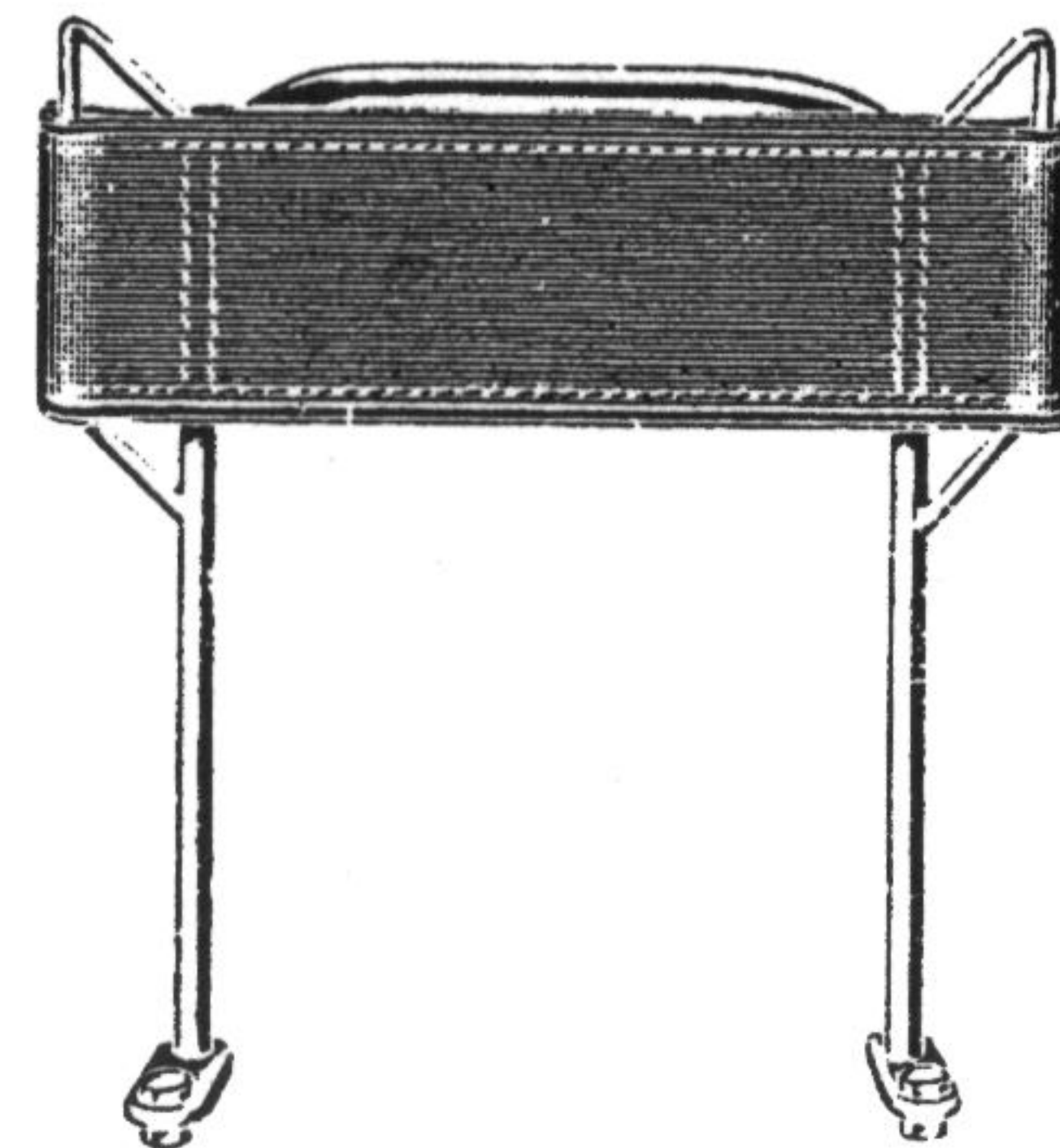

704 - Selle Biplace, Grise ou Verte

De la part de FAN DE SCOOTER

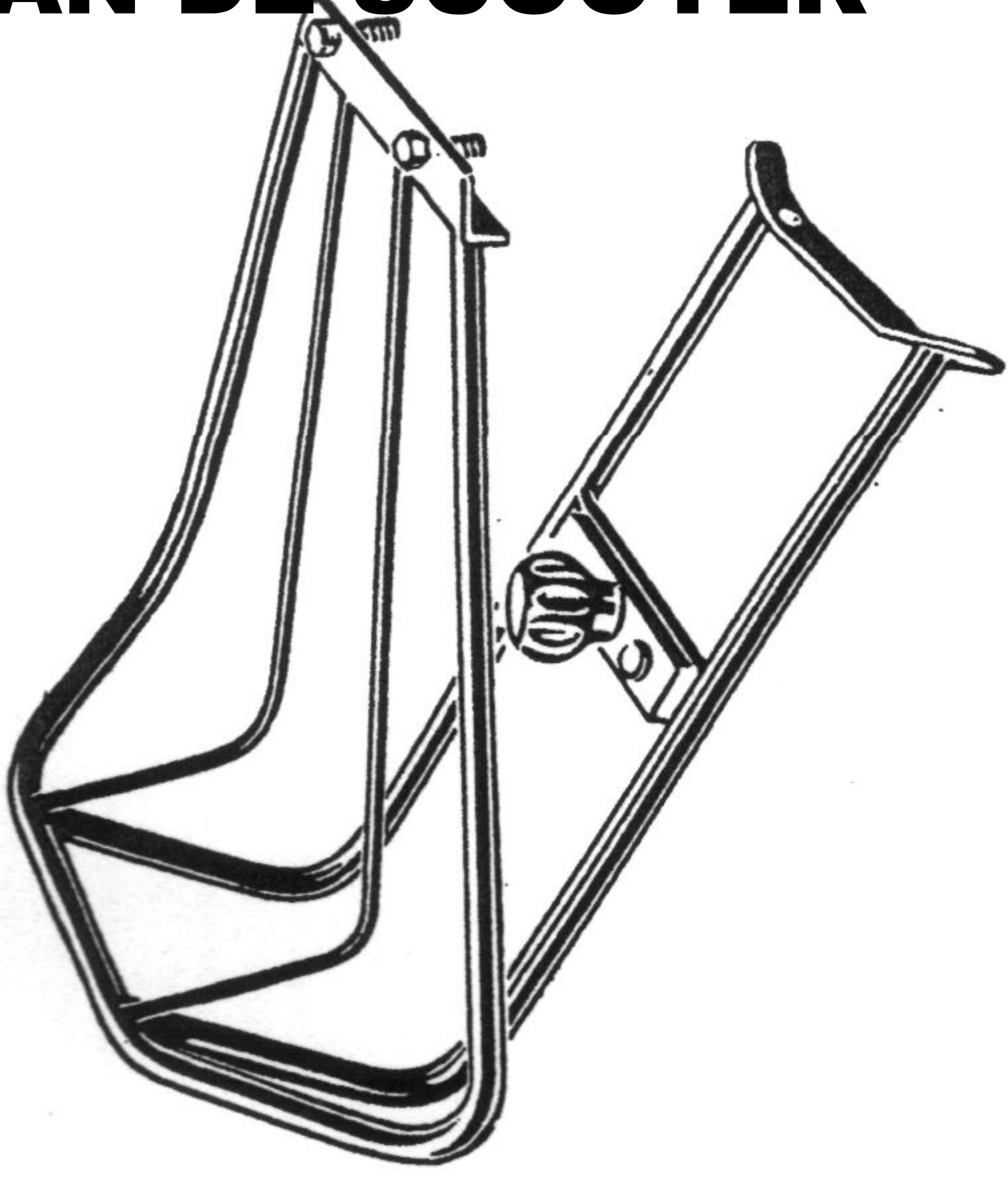

924 - Porte-Bagages AR, Type LYRE, Entièrement chromé

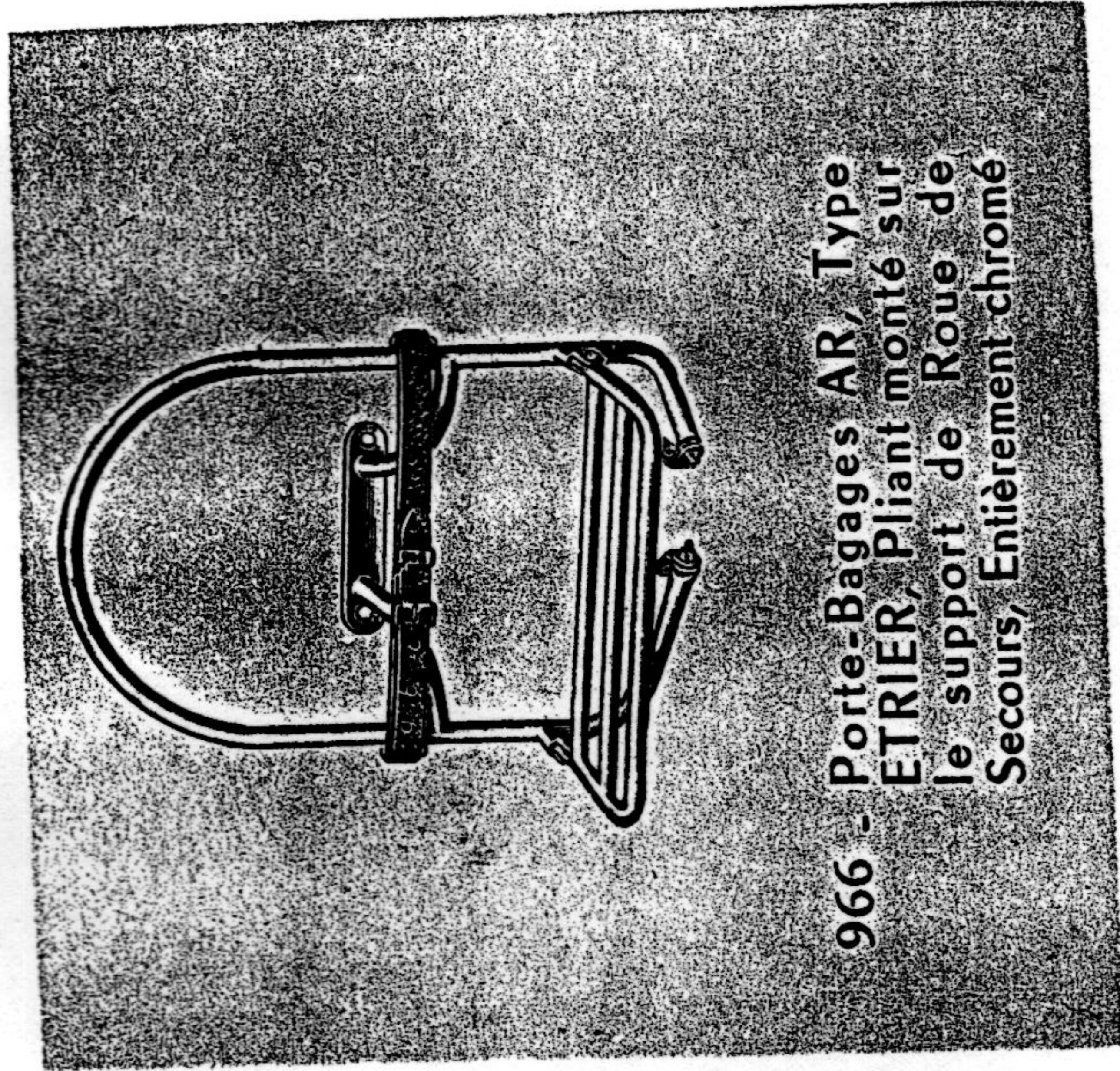

966 - Porte-Bagages AR, Type ETRIER, Pliant monté sur le support de Roue de Secours, Entièrement chromé

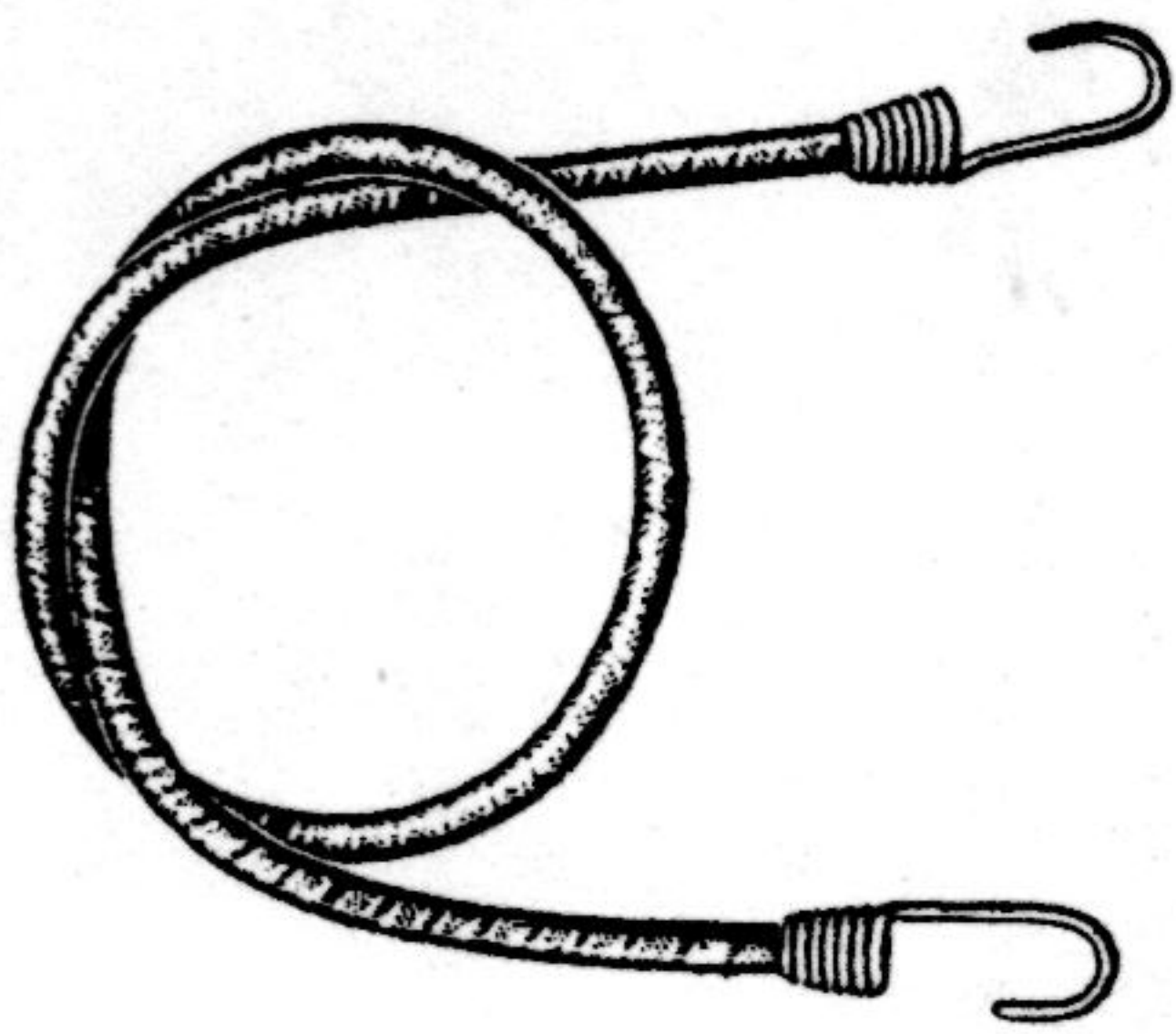

971 - Sandow 1^{er} Choix pour Porte-Bagages

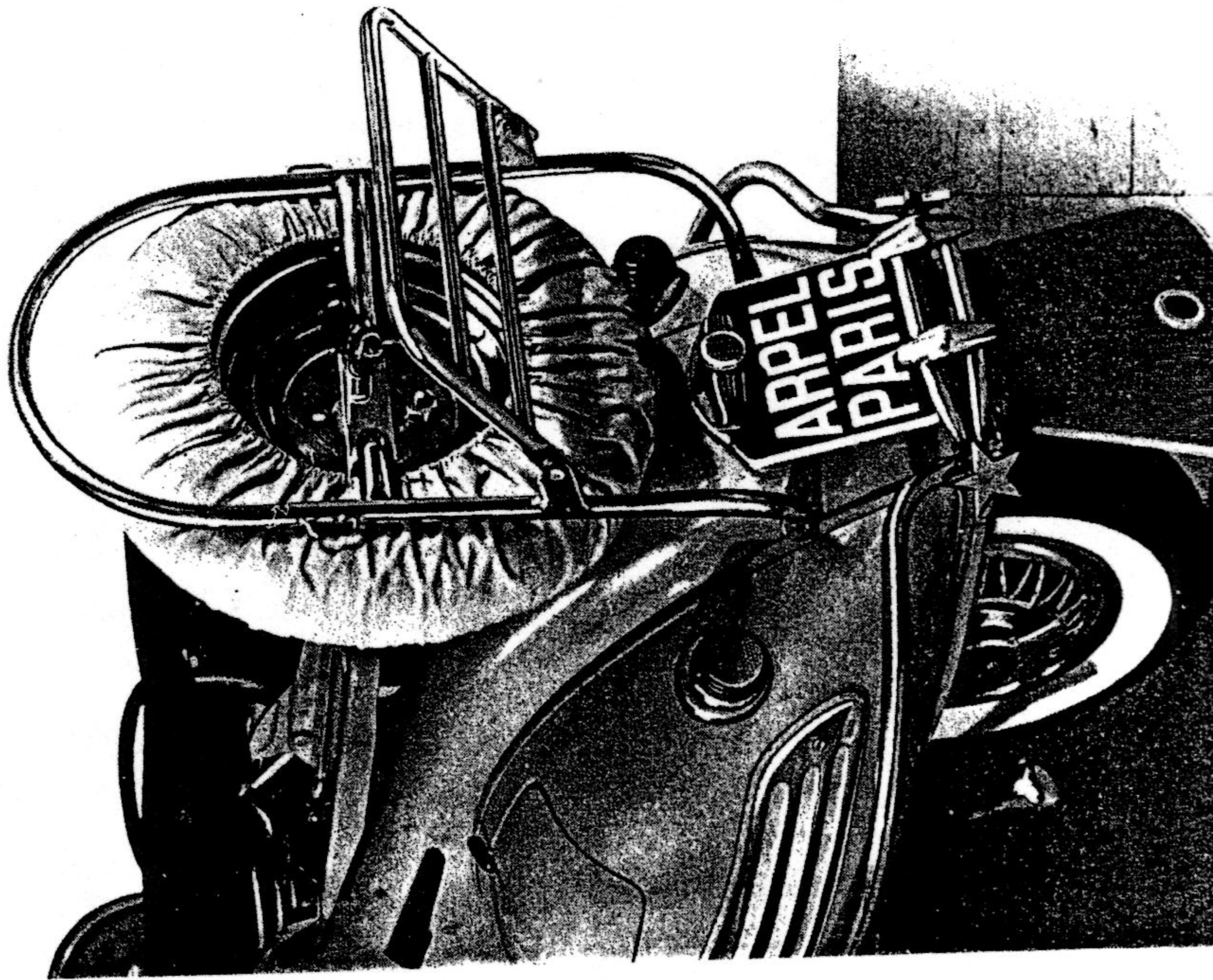

Porte - Bagages

838 - Porte-Bagages AV Pliant Fixe, Entièrement chromé

858 - Porte-Bagages AV Pliant Fixe, Entièrement émaillé

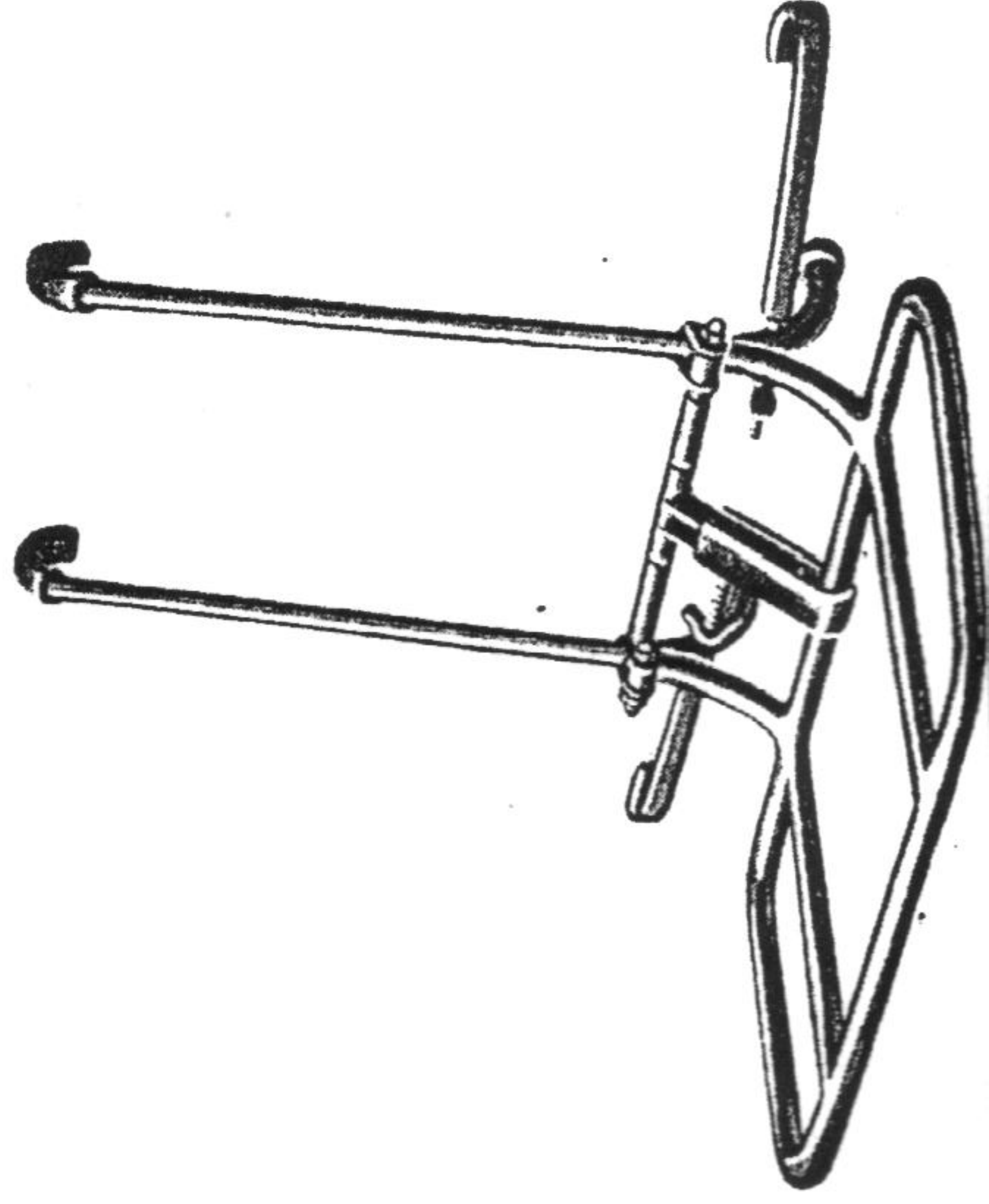

838 A - Porte - Bagages Avant pliant, Grand Luxe entièrement chromé

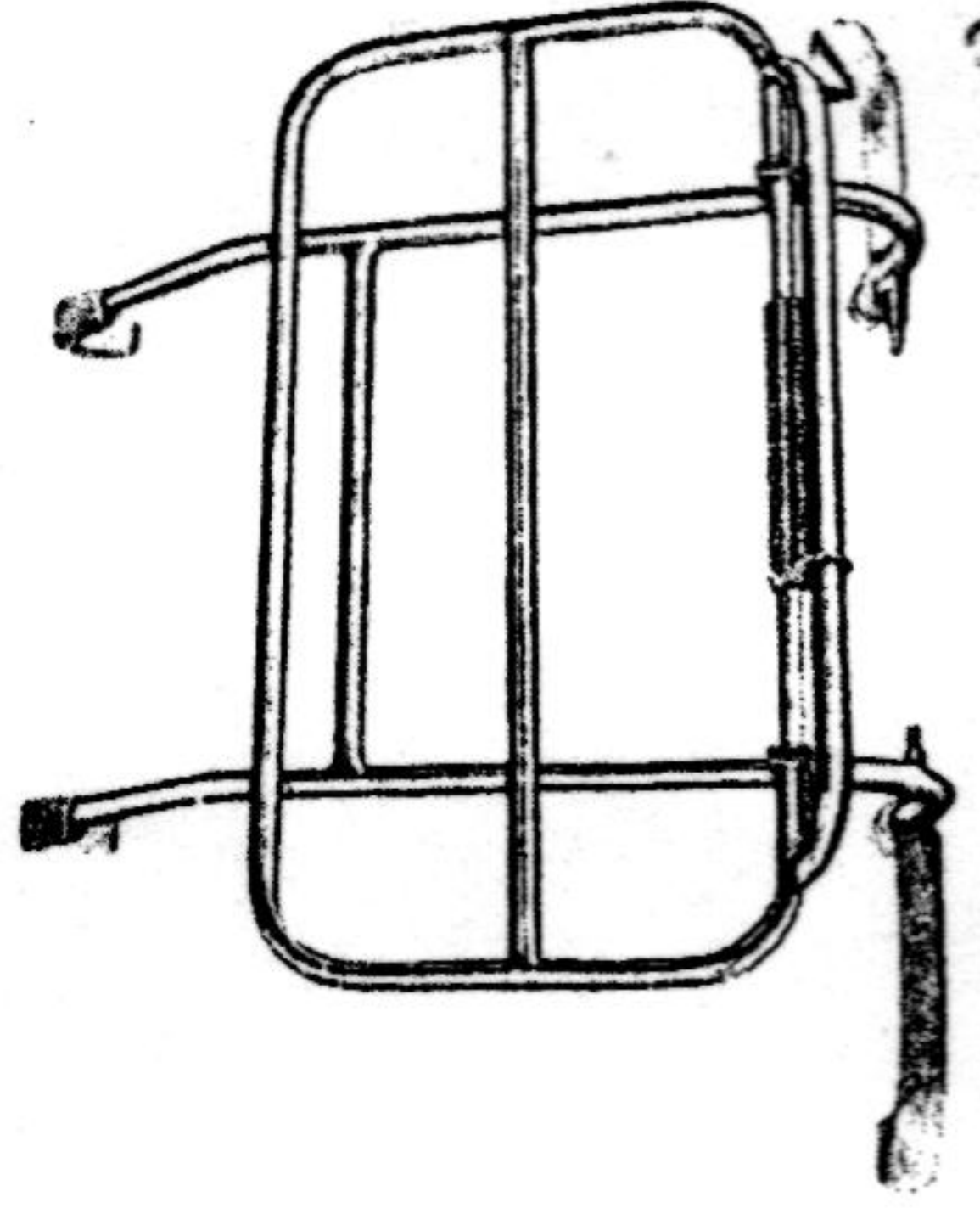

238

De la part de FAN DE SCOOTER

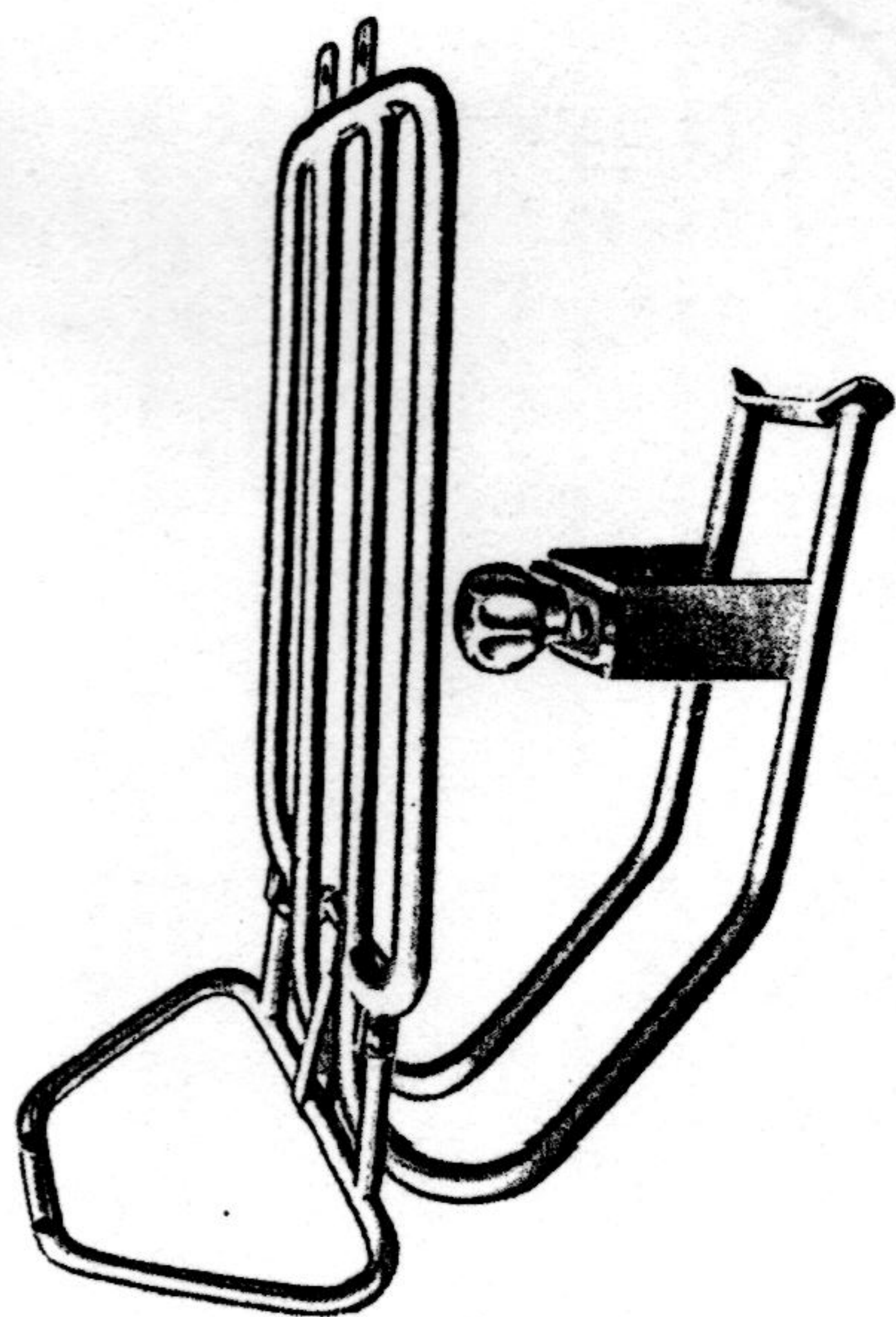

1049

1049 - Porte-Bagages AR horizontal
à poignée pliante à ressort,
entièrement chromé

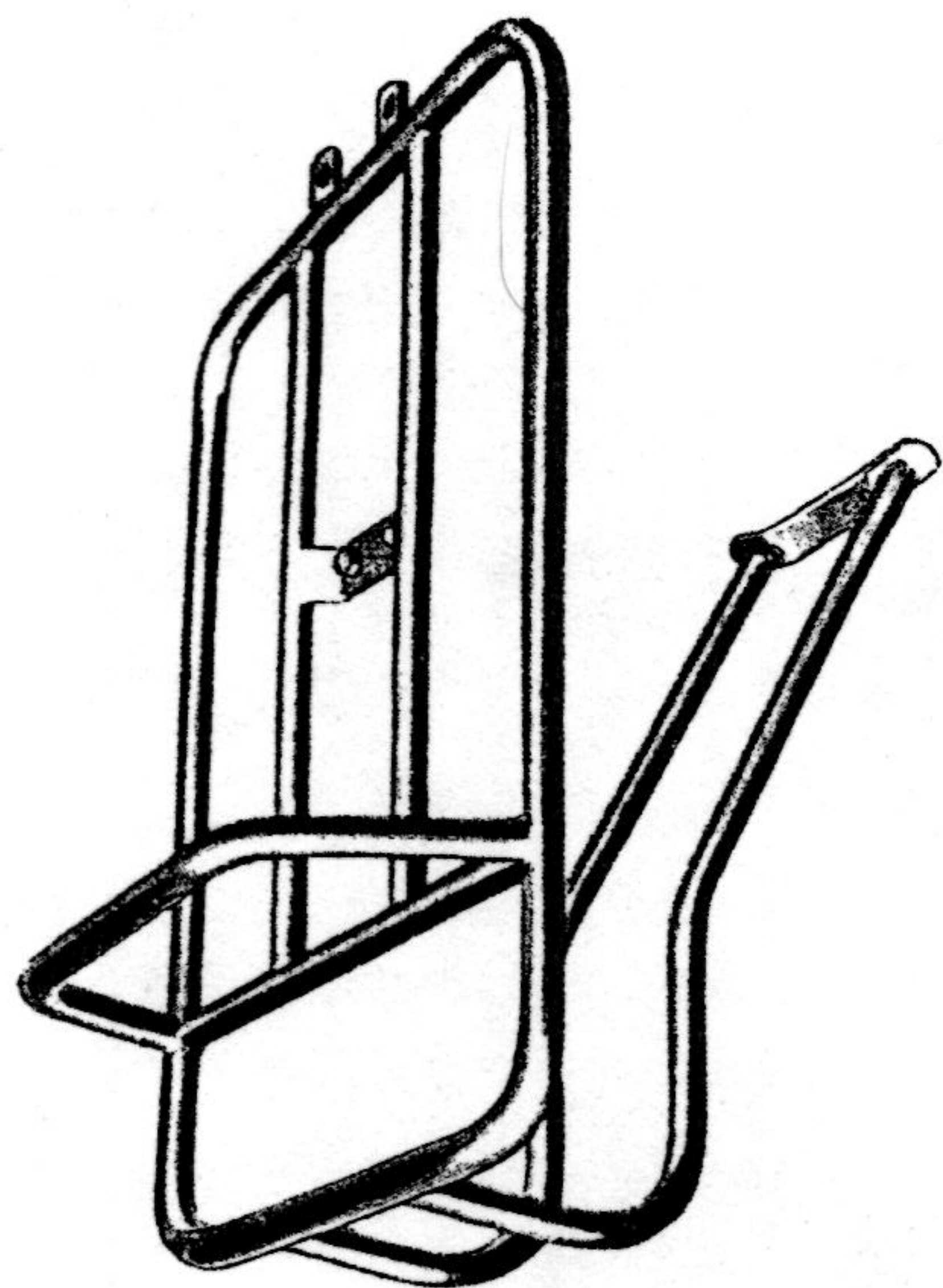

1051 - Porte-Bagages AR horizontal
avec porte-jerrican entière-
ment chromé

AA



816

816 - Porte-Bagages AR large avec porte-roue
monté sur silent-bloc

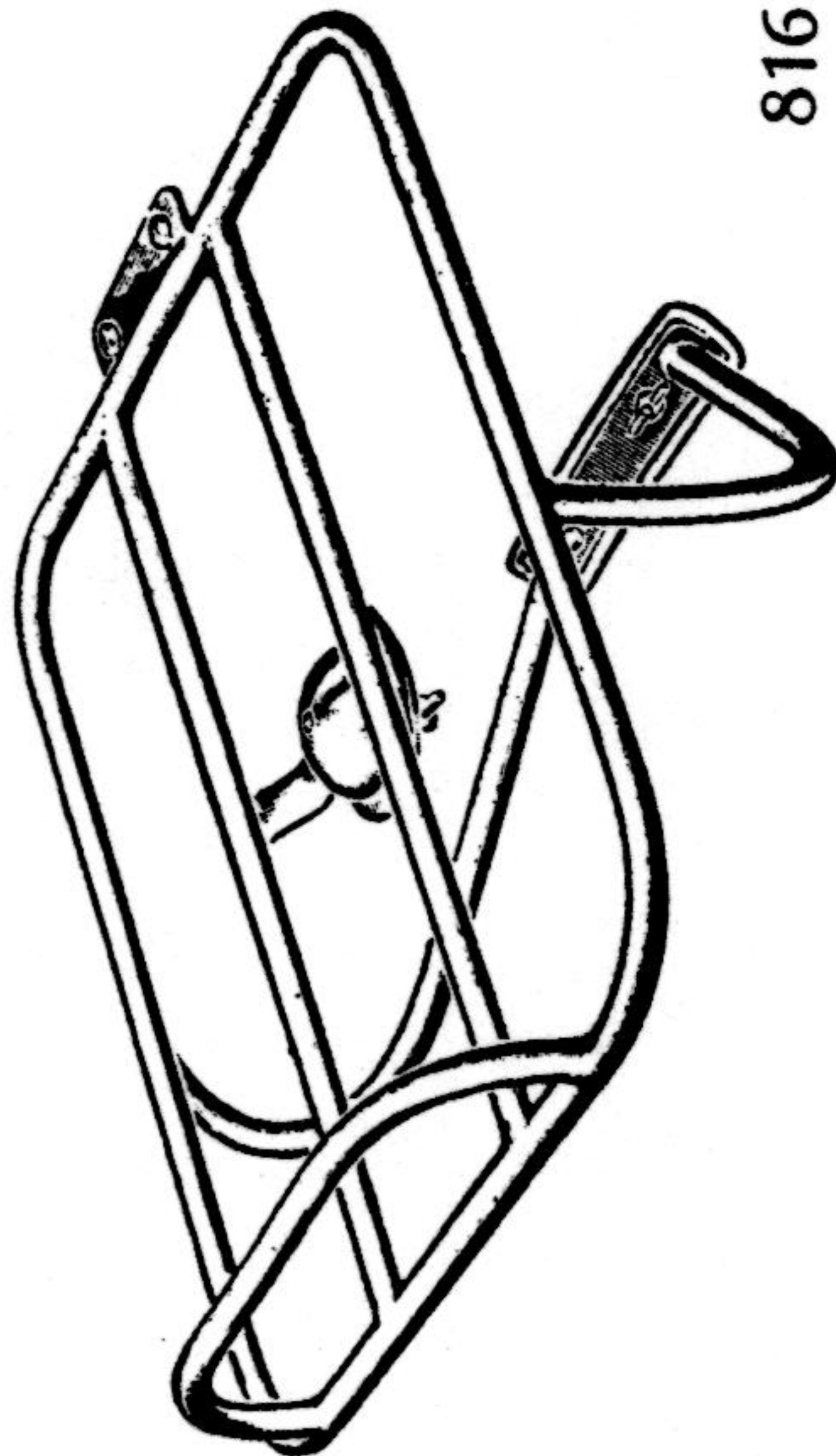

839

839 - Porte-Bagages AR à poignée fixe avec
porte-roue entièrement chromé

859

859 - Porte-Bagages AR à poignée fixe avec
porte-roue entièrement émaillé

1052

1052 - Porte-Bagages 839 sans poignée

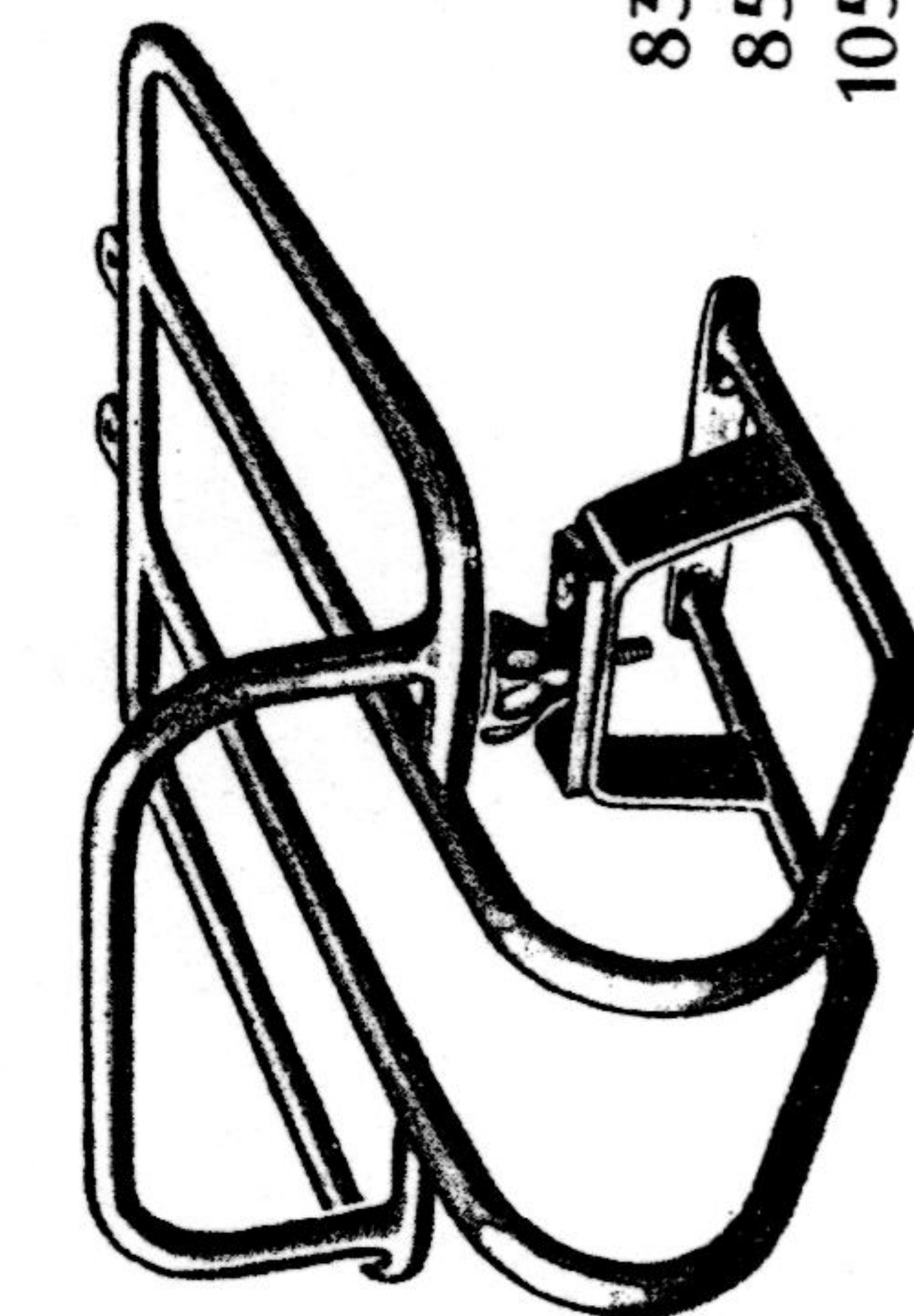

1049

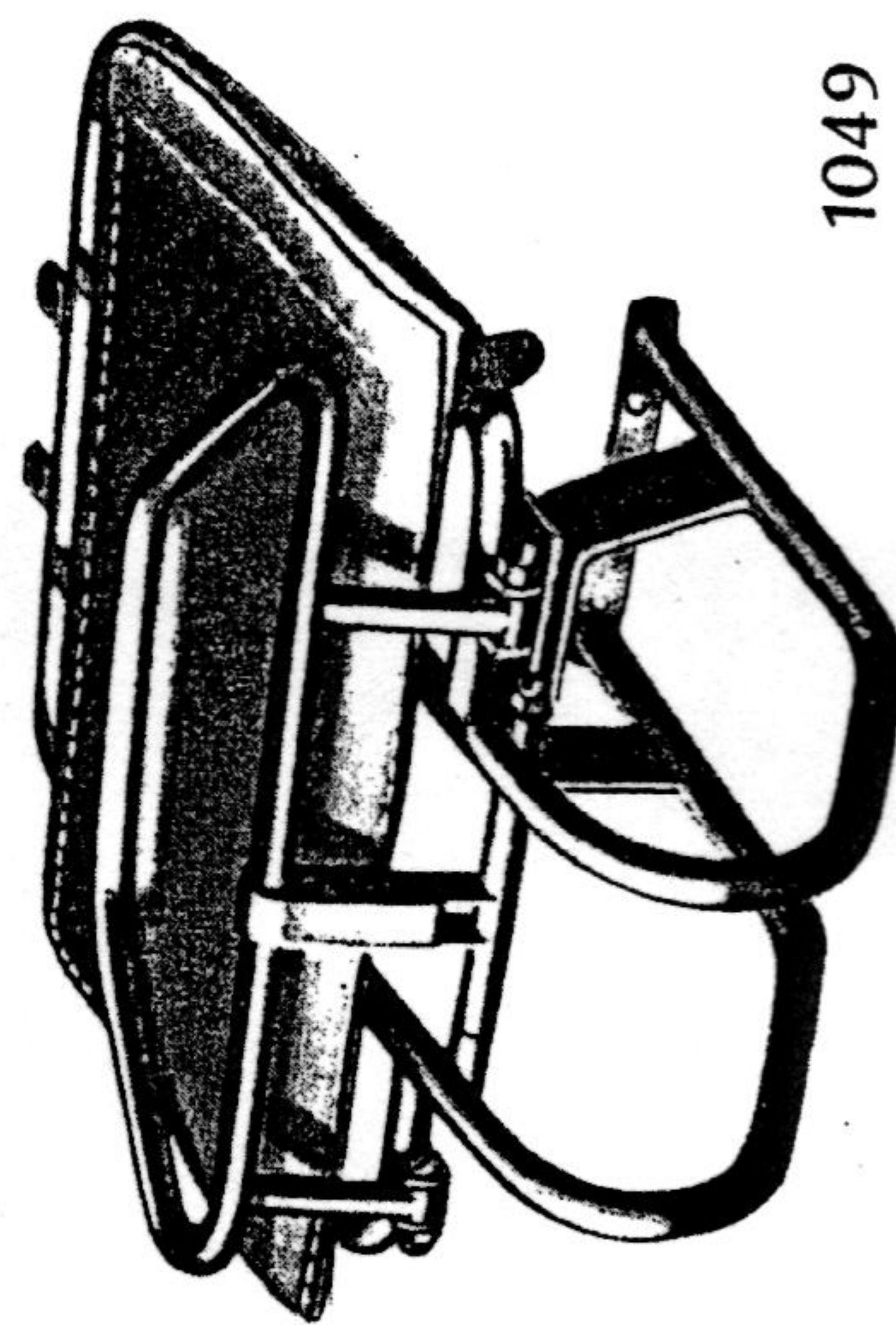

**De la part de
FAN DE SCOOTER**

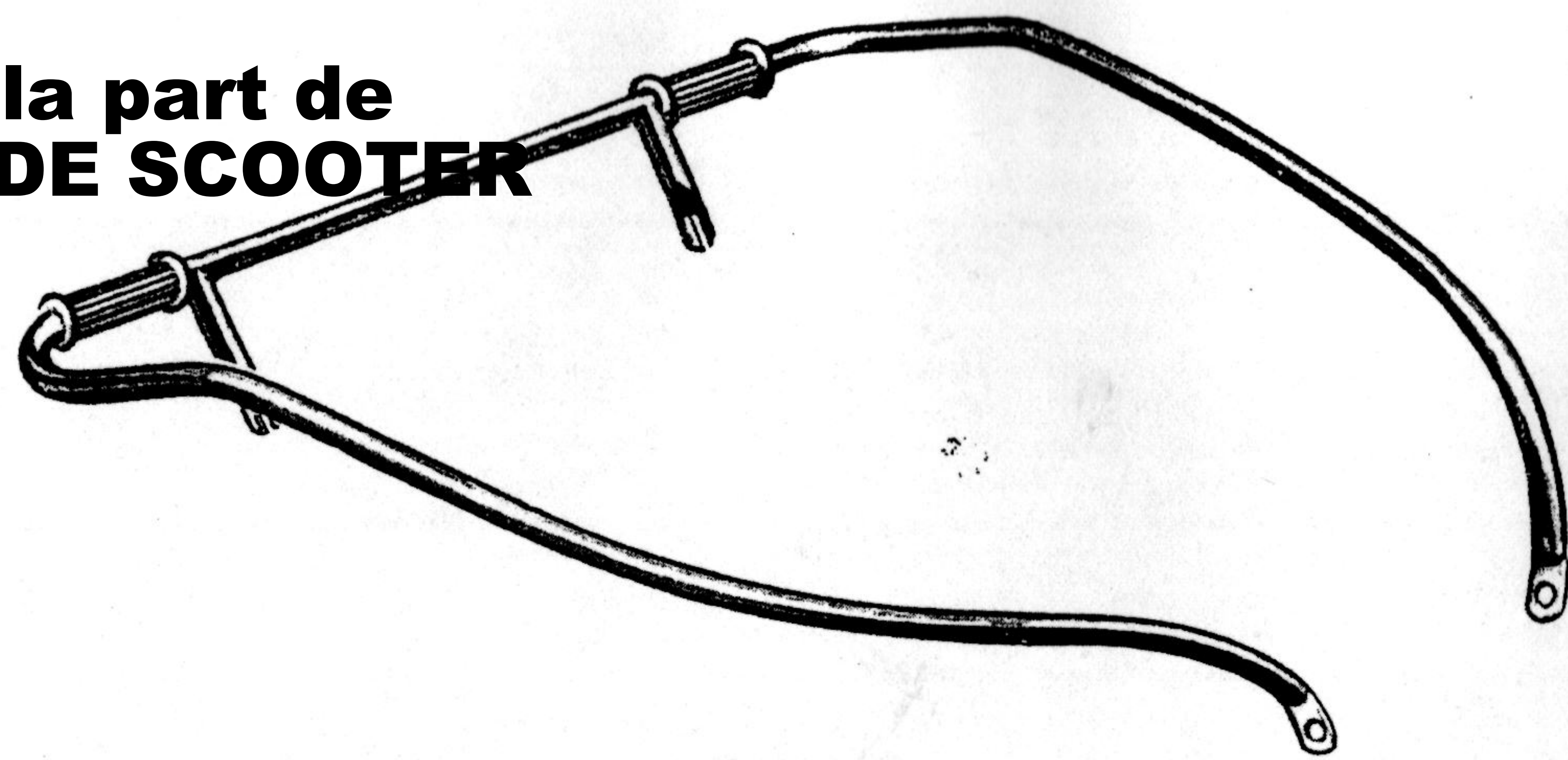

835 - Pare-Chocs latéraux 56, avec Pare-Chocs AR simple entièrement chromé

835A - Pare-Chocs latéraux, grand luxe, avec Pare-Chocs AR double entièrement chromé

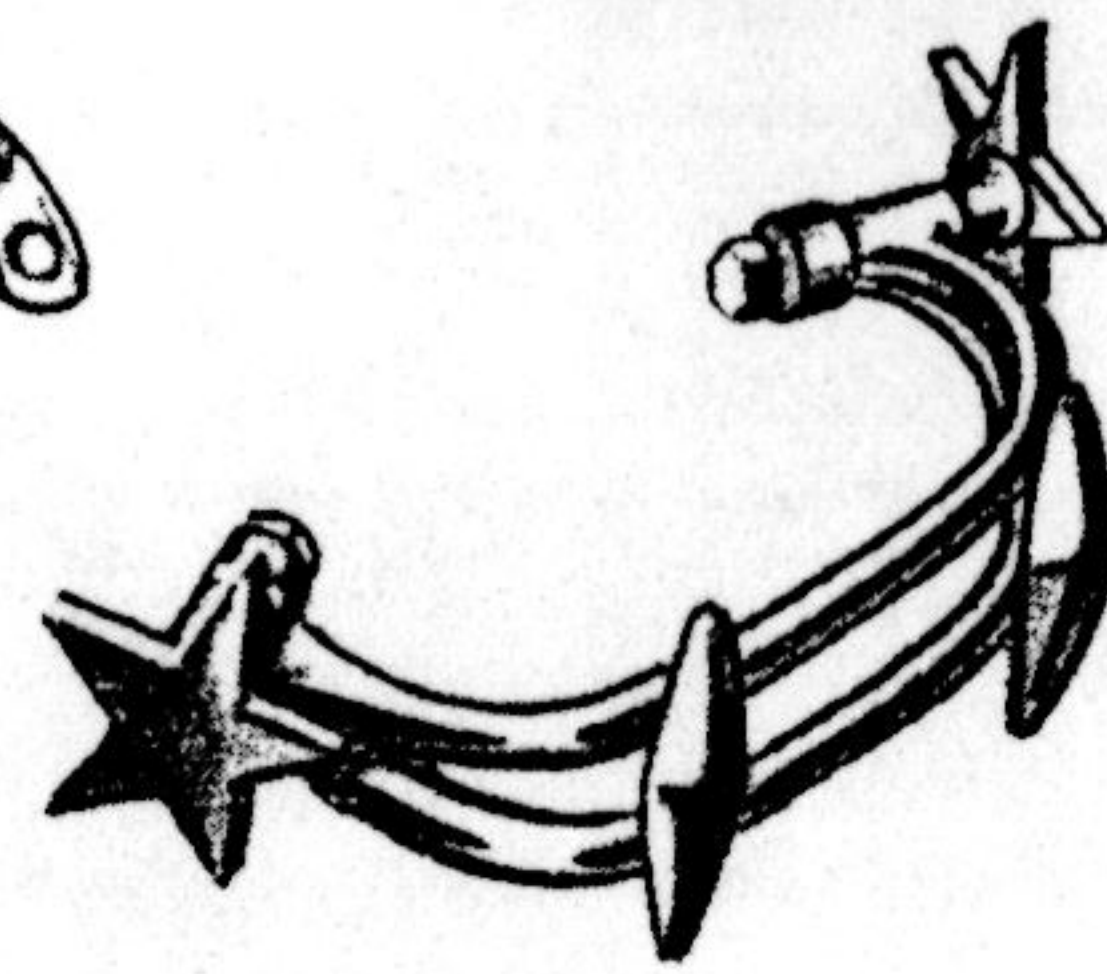

835 A

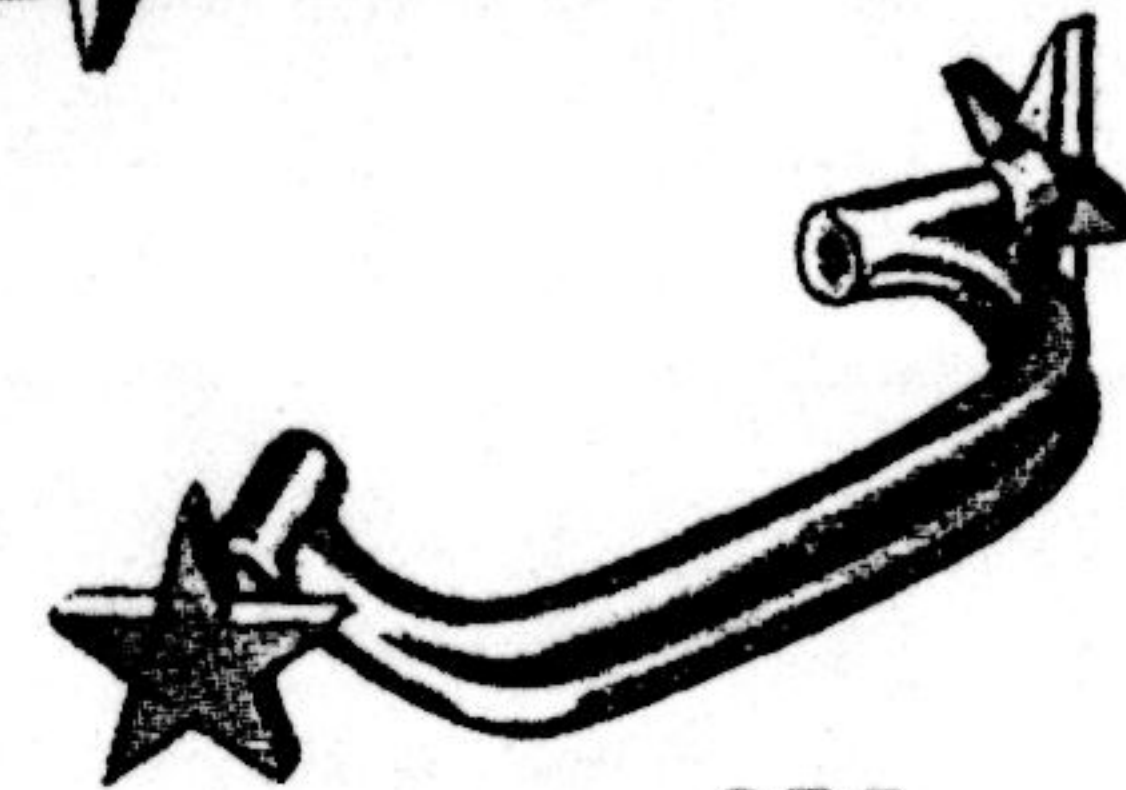

835

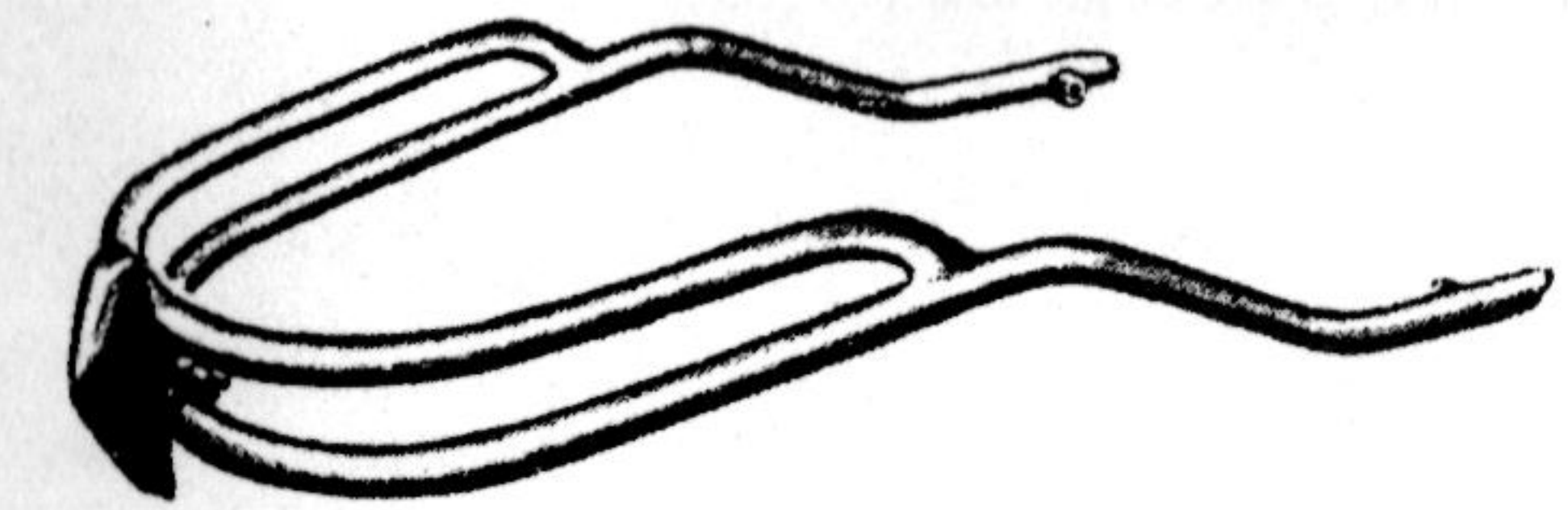

834A - Pare-Chocs AV double tube chromé, très enveloppant

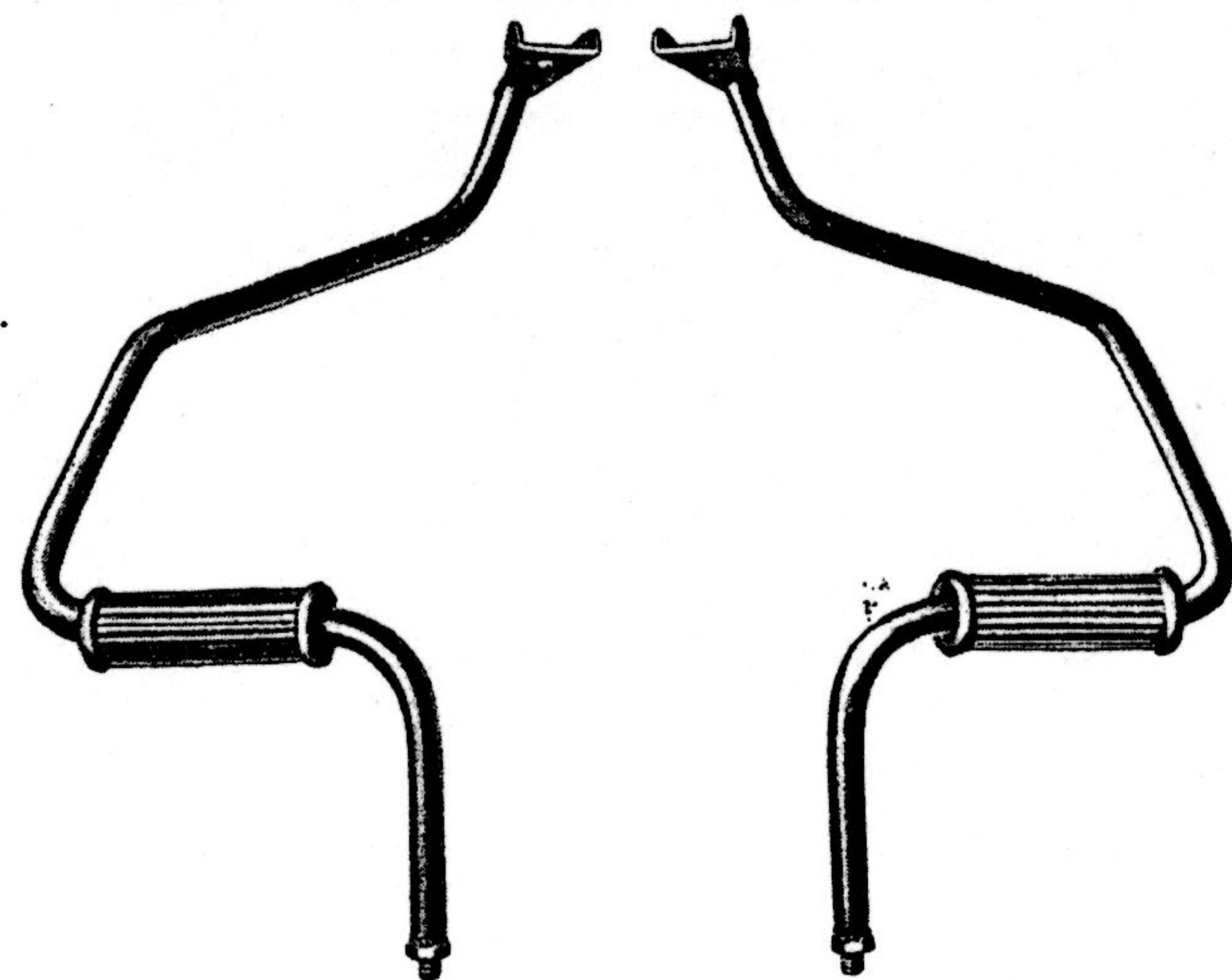
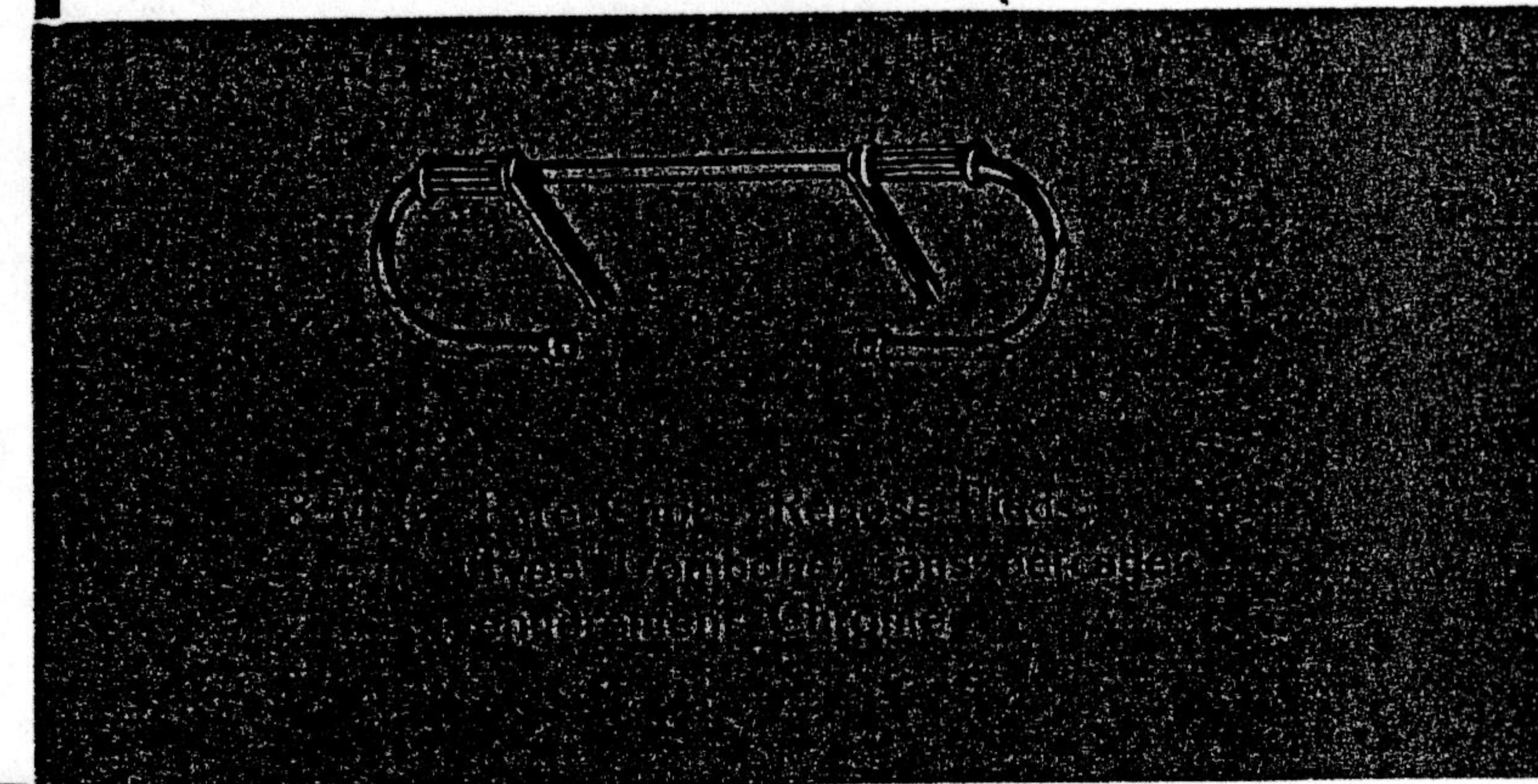

836 - Pare-Jambes Repose-Pieds, 2 pièces, chromé, modèle 56

853 - » » » » sans perçage

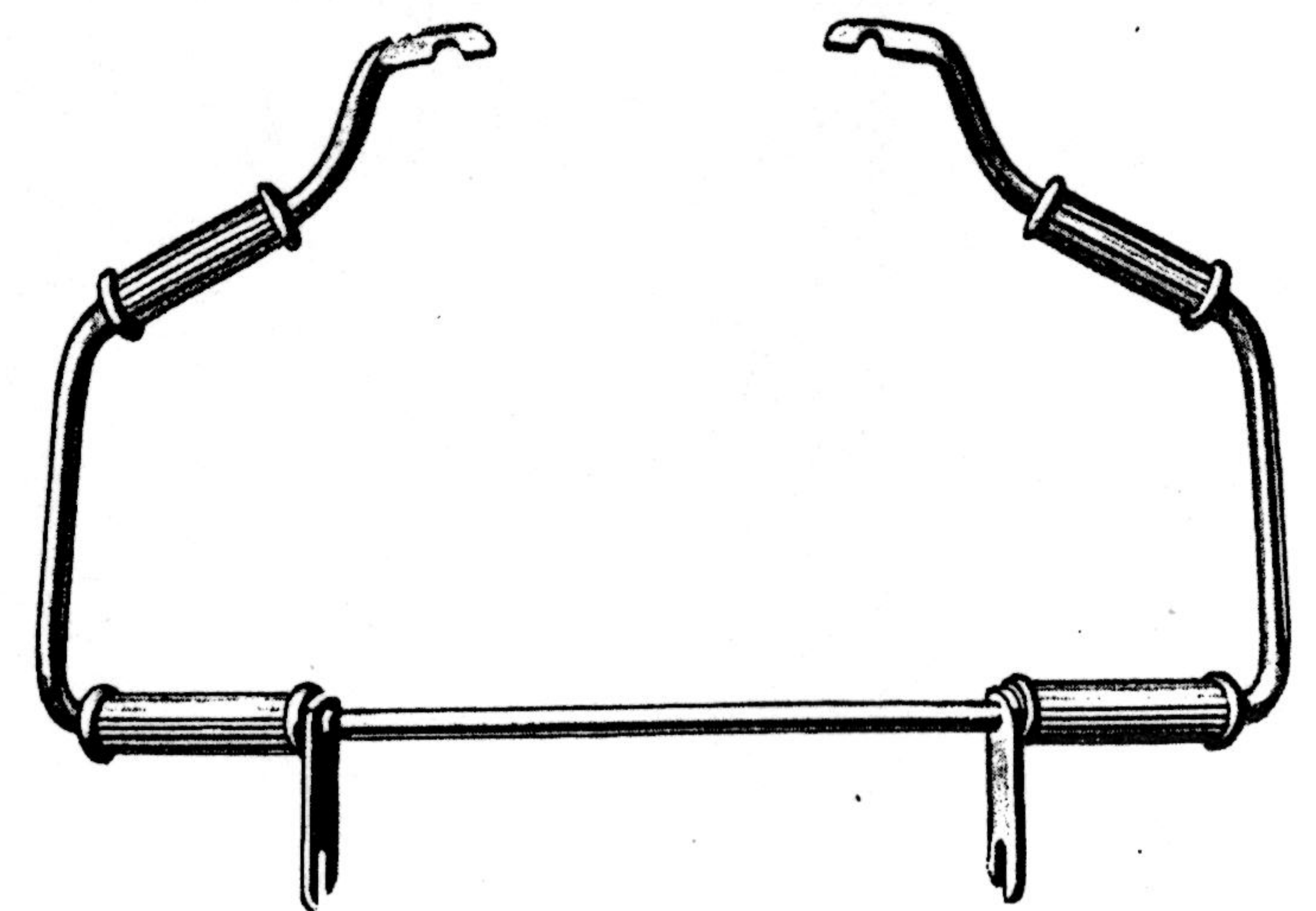
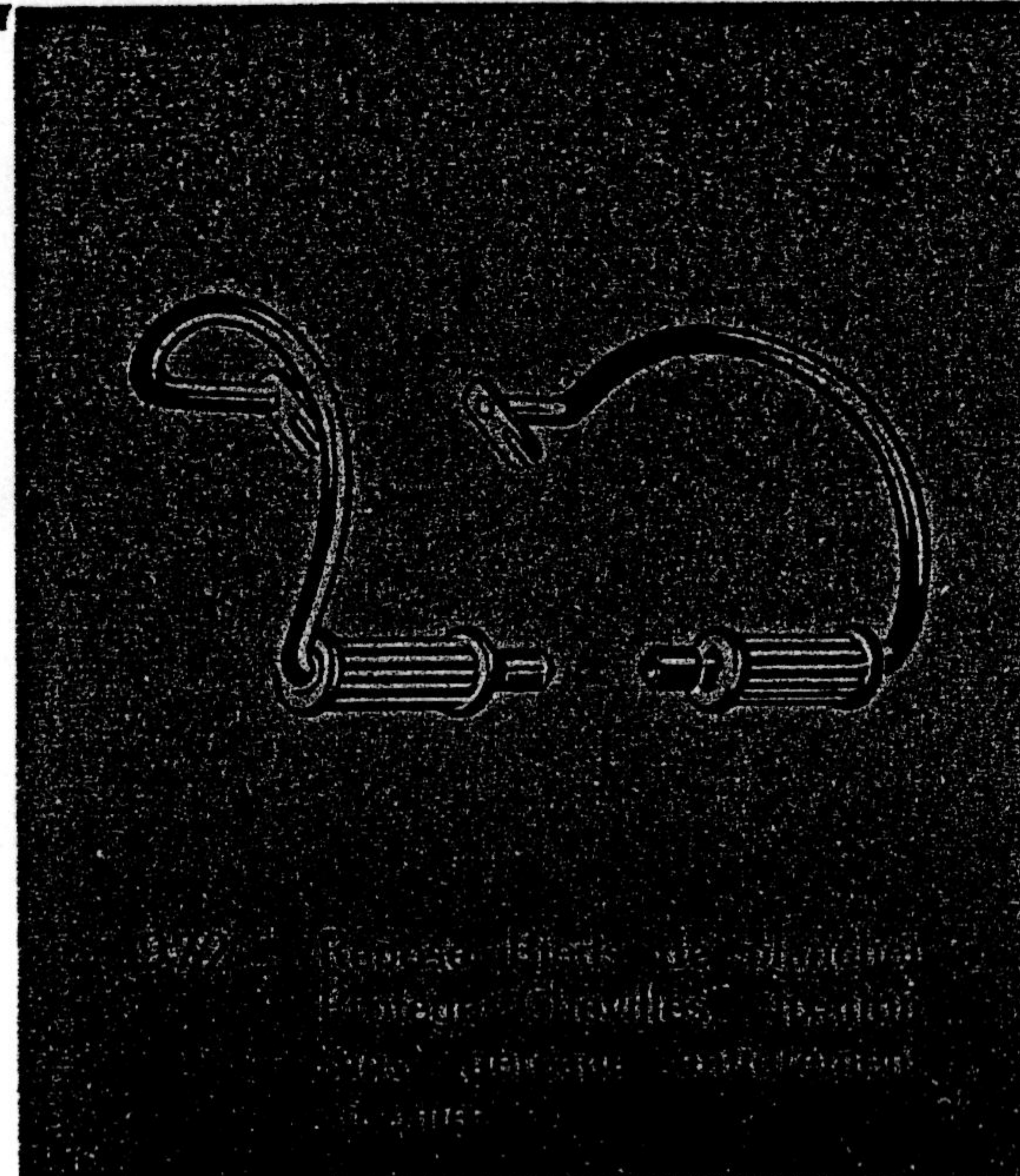

837 A - Pare-Jambes 3 pièces, 4 caoutchoucs, en arceau fixation sans perçage, entièrement chromé

De la part de
VAN D

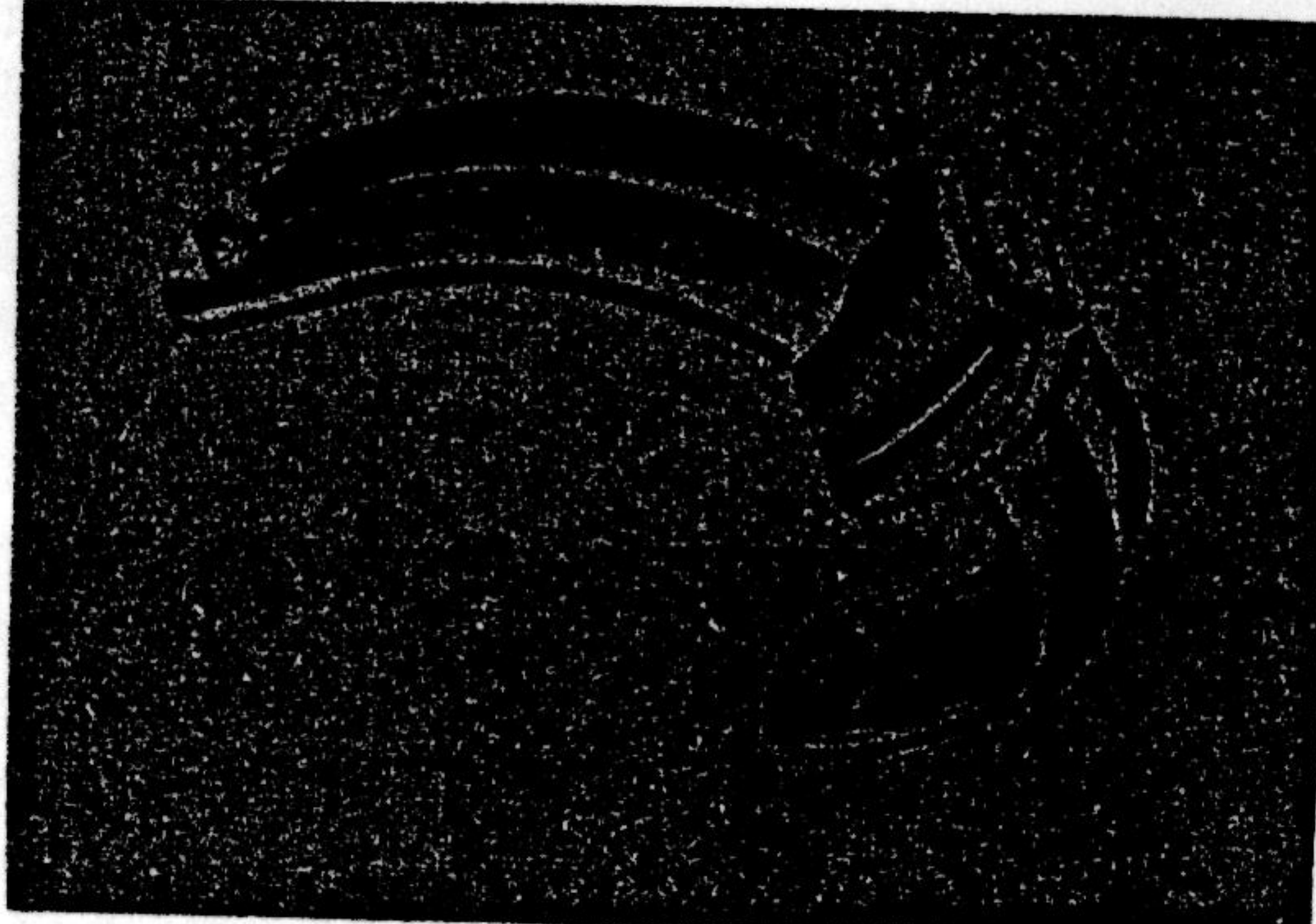
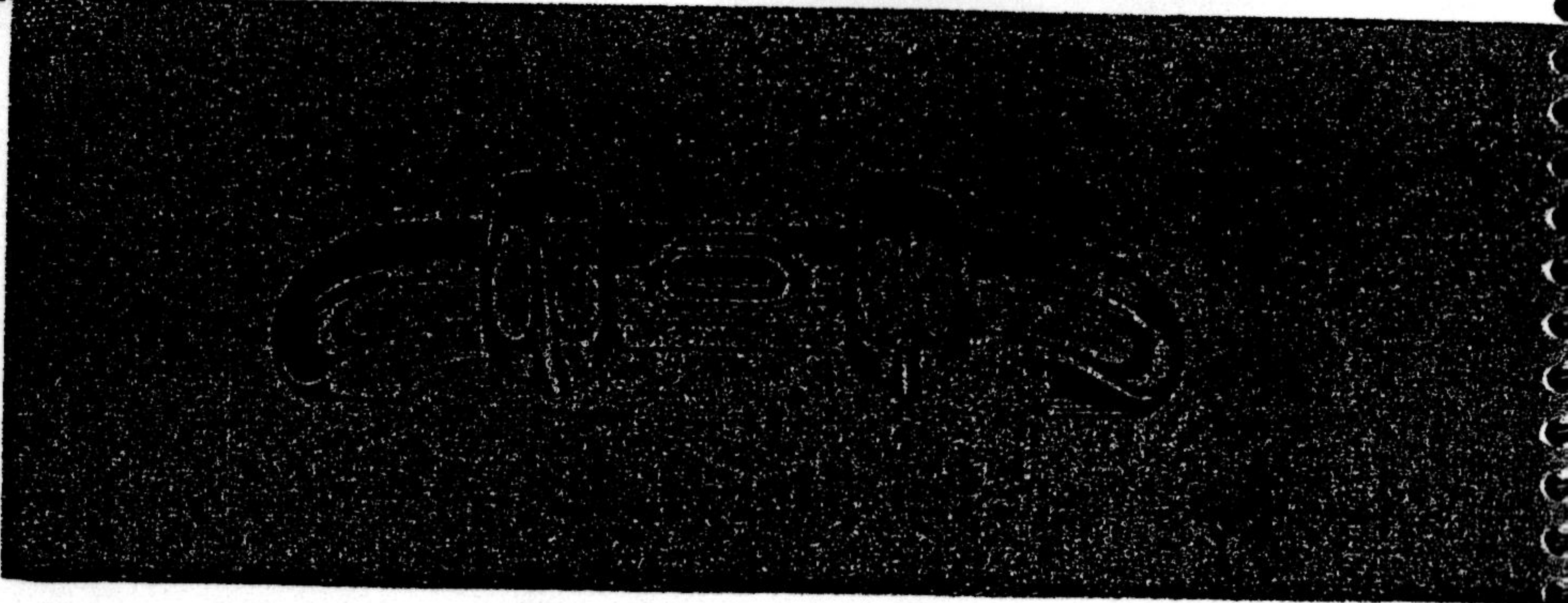
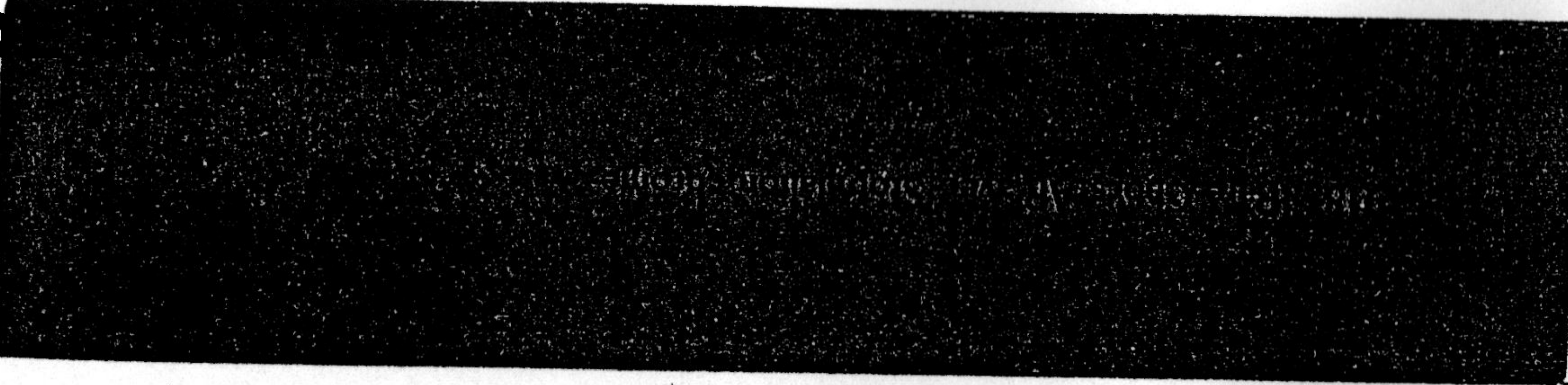

963 - Pare-Chocs AV, type
" Gladiateur "
laiton chromé

Pare - Chocs

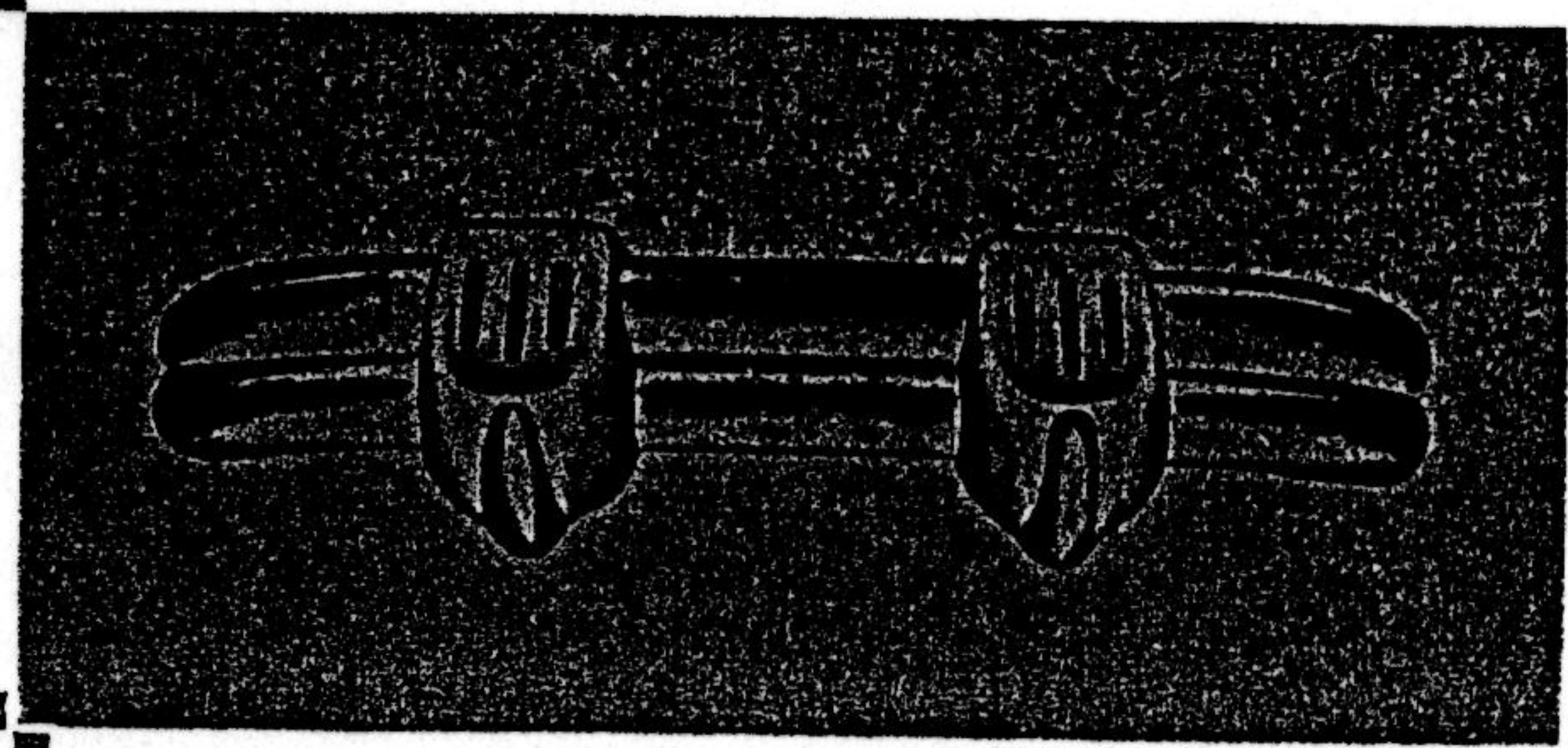

963A - Pare-chocs AR, type
" Gladiateur "
laiton chromé

834C - Pare - Chocs AV tubulaire
double, cuivre, nickelé,
chrome

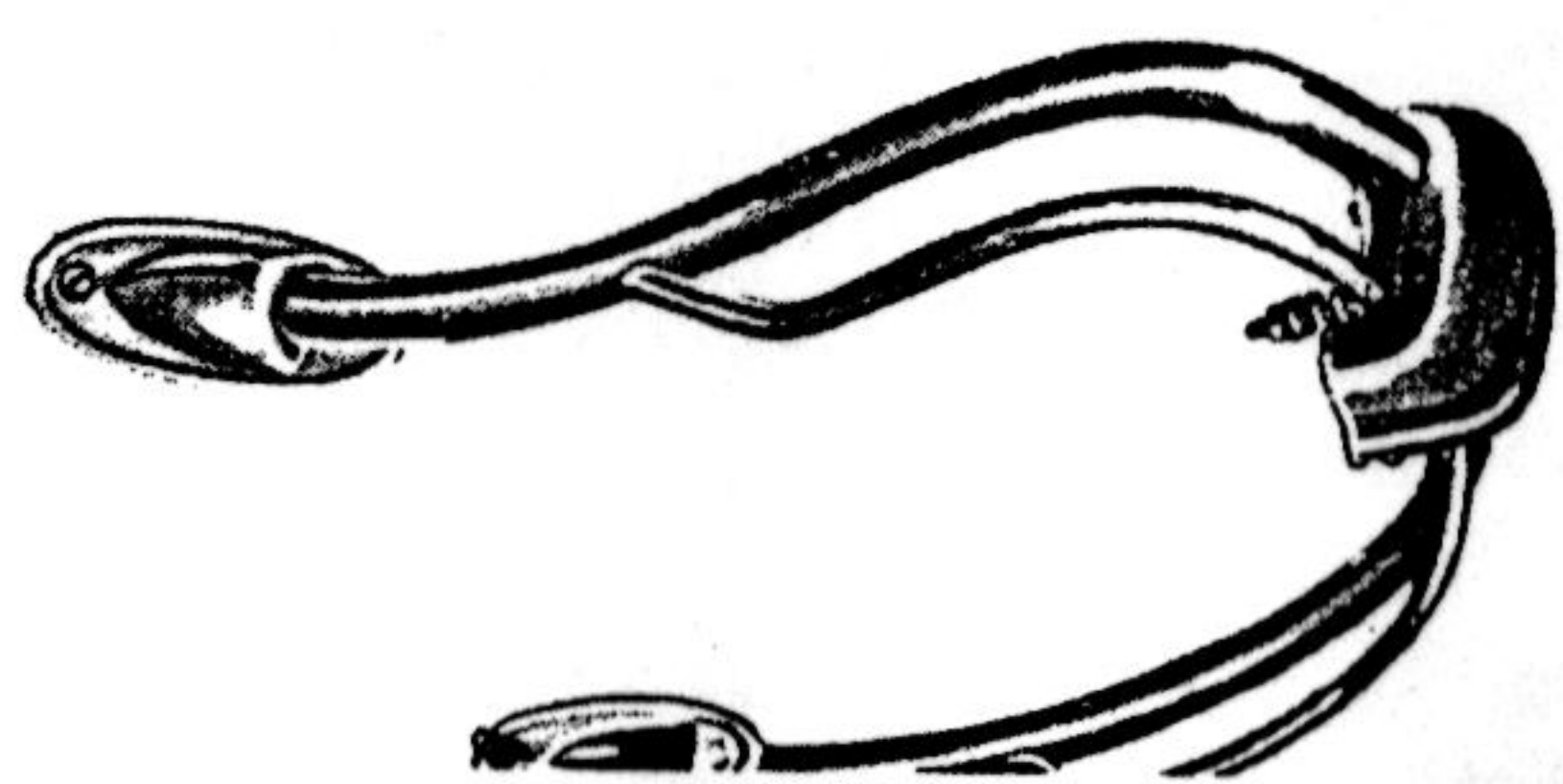

965 - Pare - Chocs AV tubulaire
simple avec motif chrome



De la part de FAN DE SCOOTER

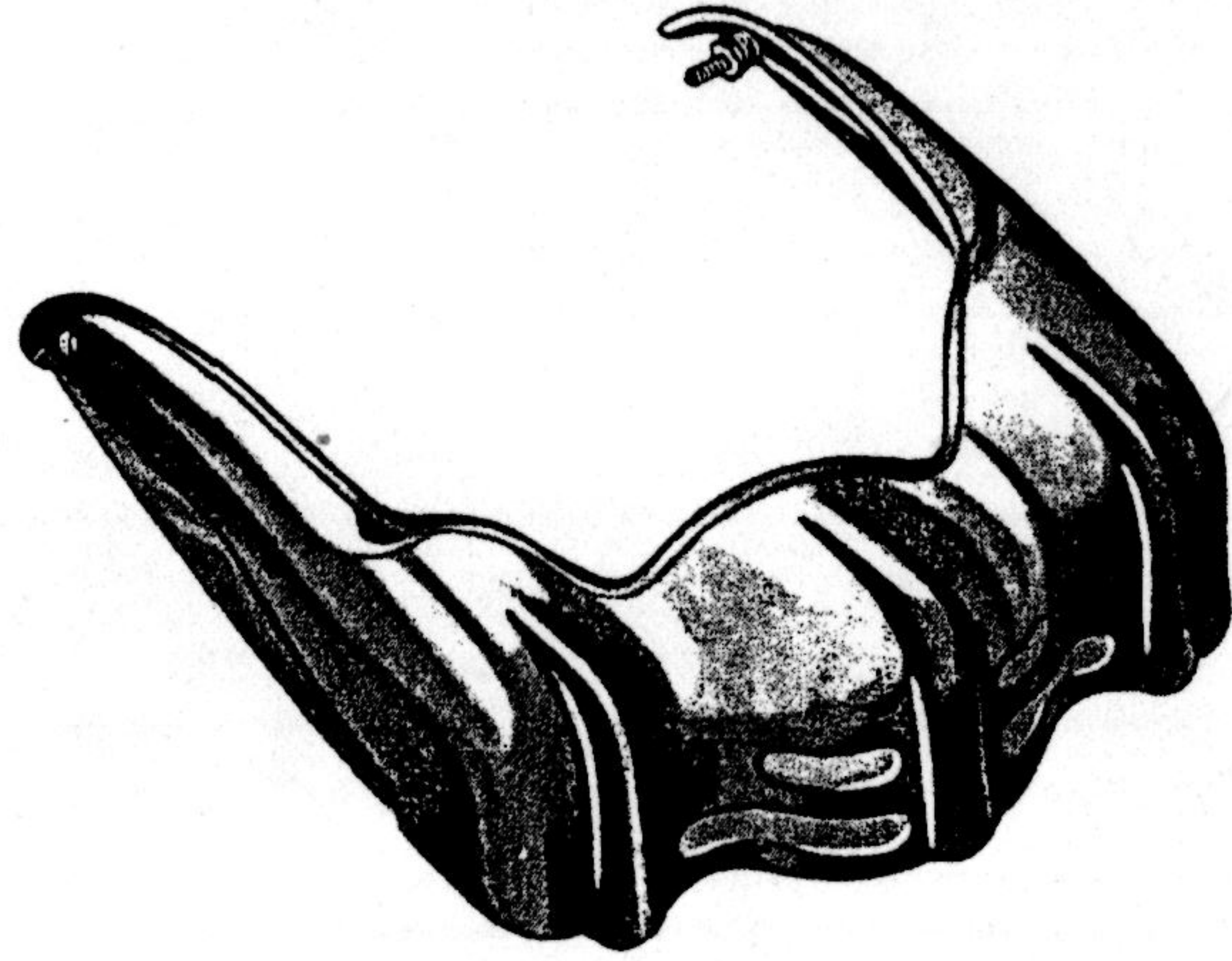

818 A

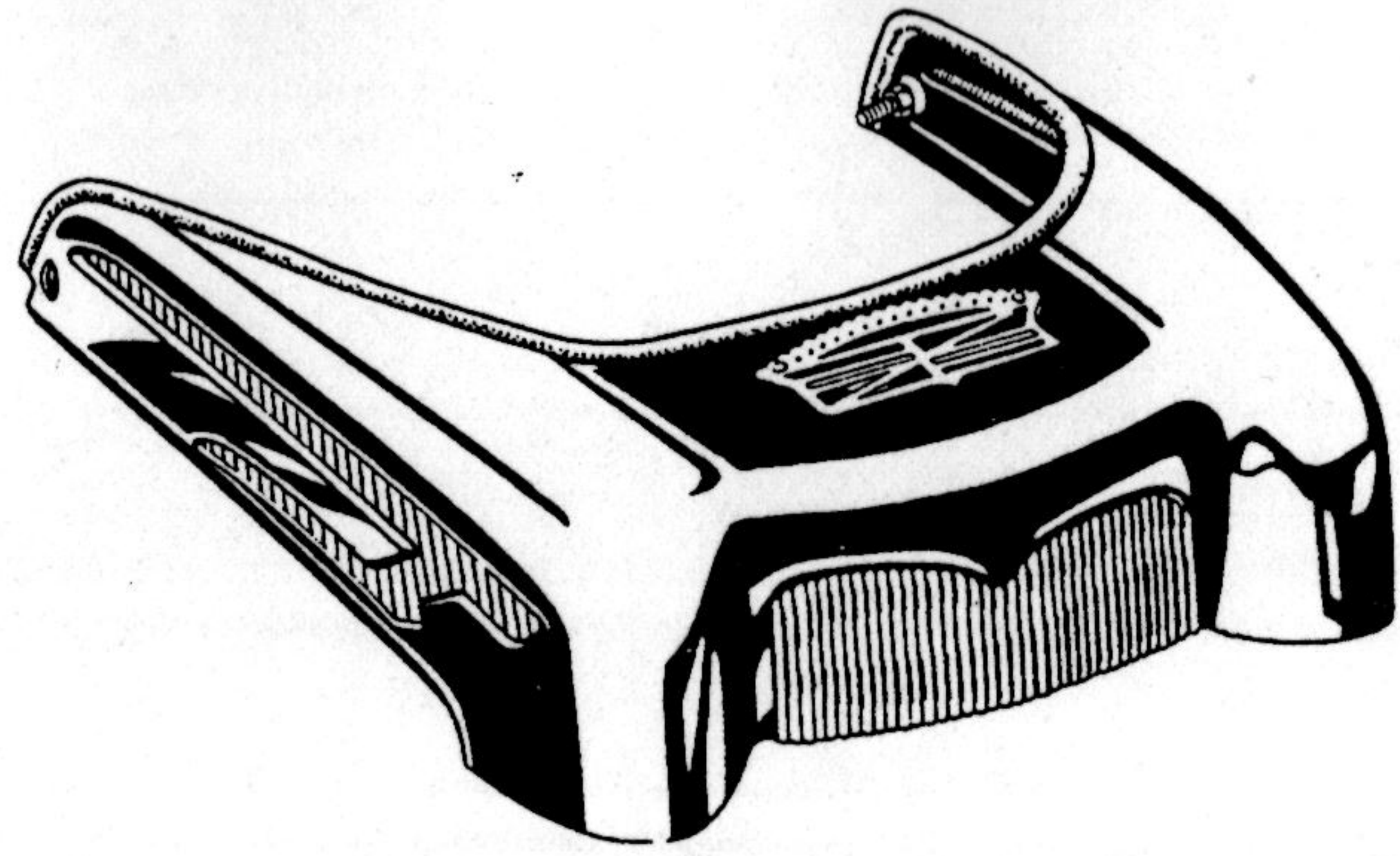

964

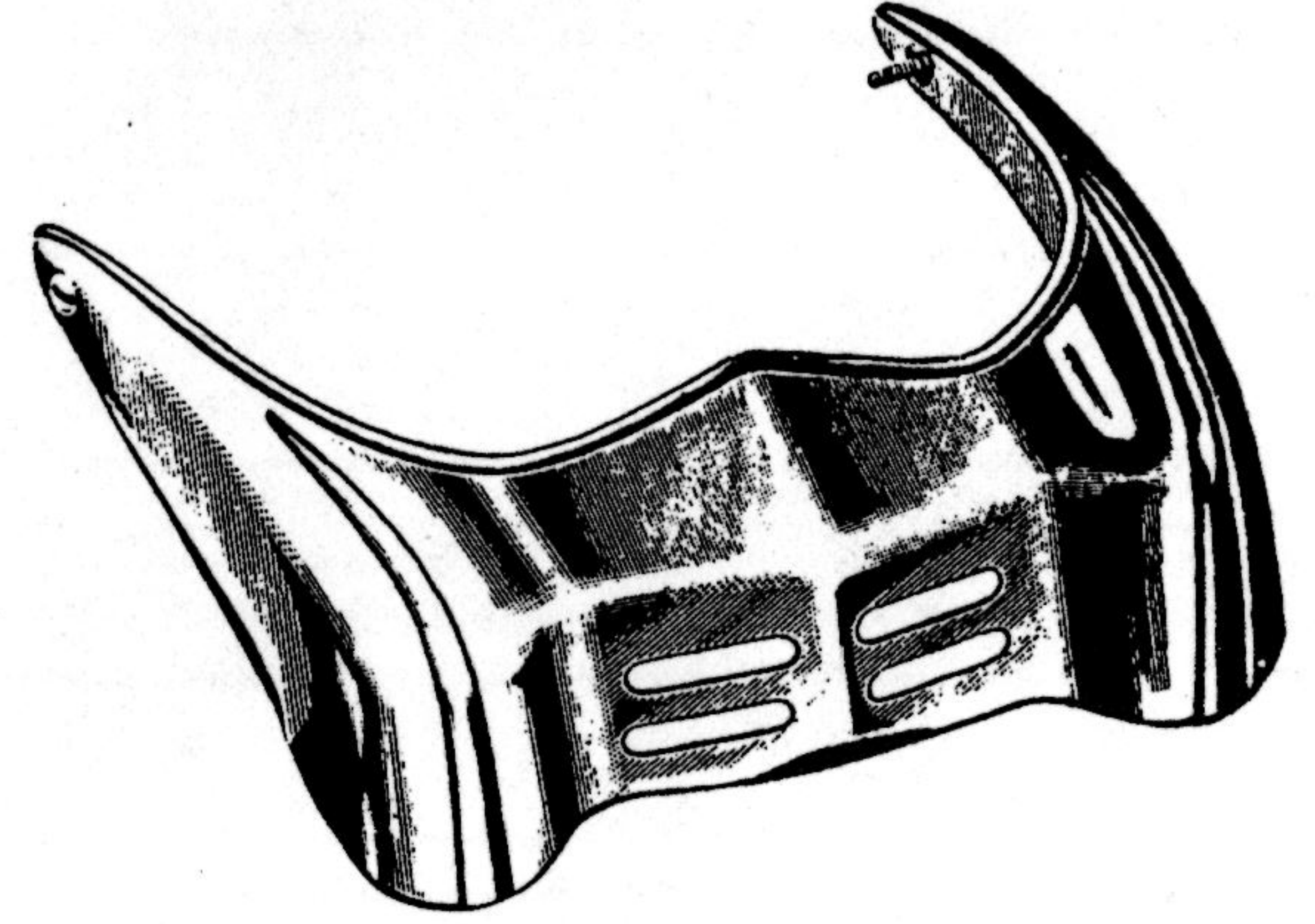

818



916

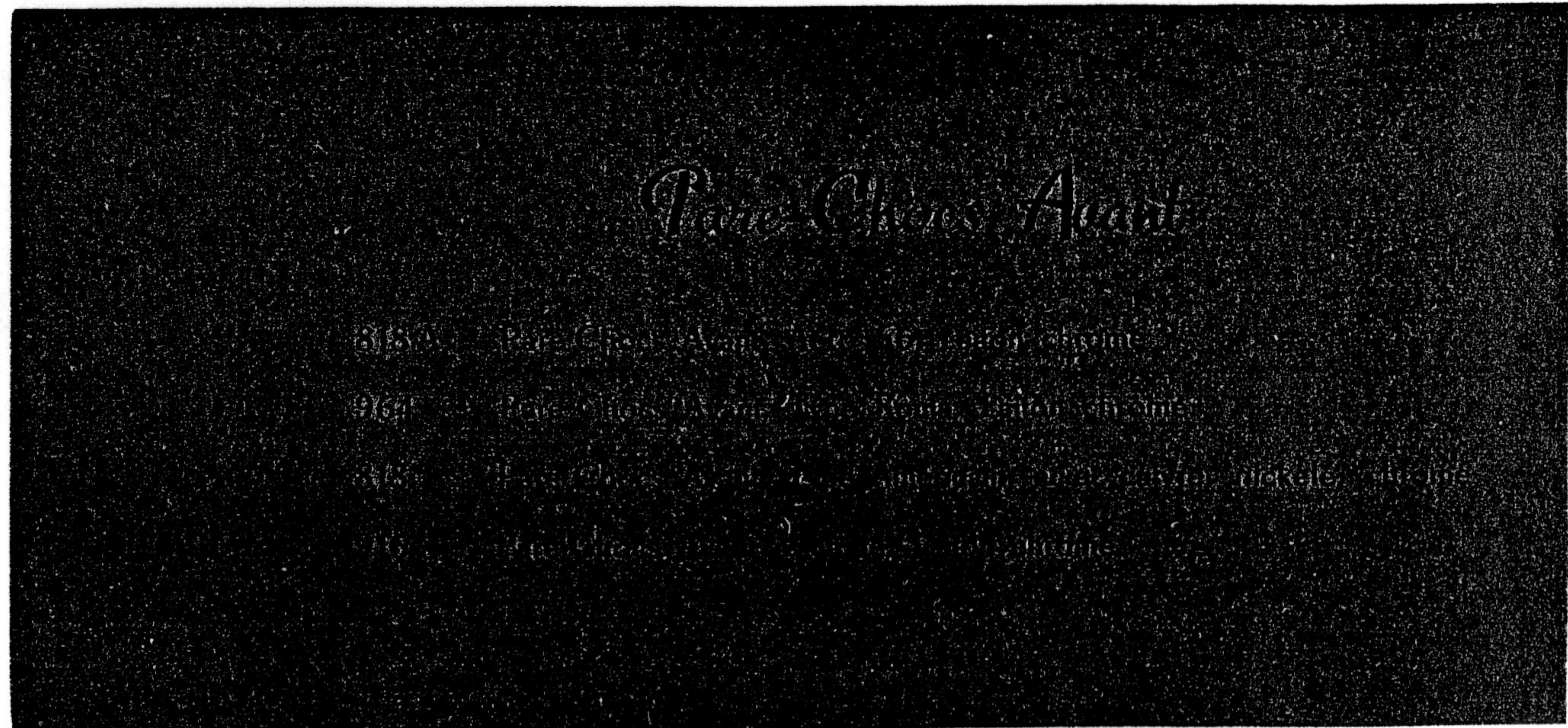

**De la part de
FAN DE SCOOTER**

1039

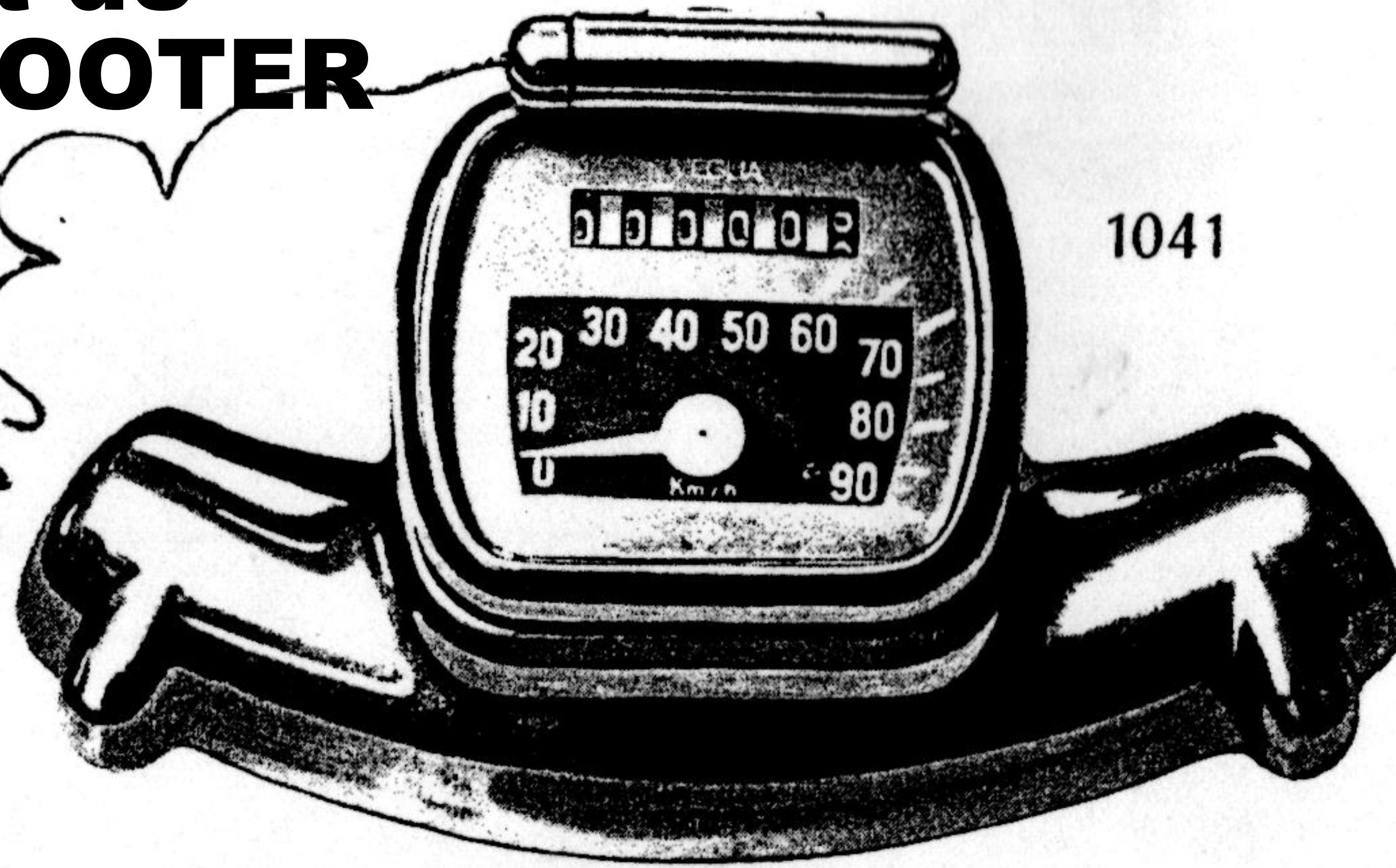

1041

1042

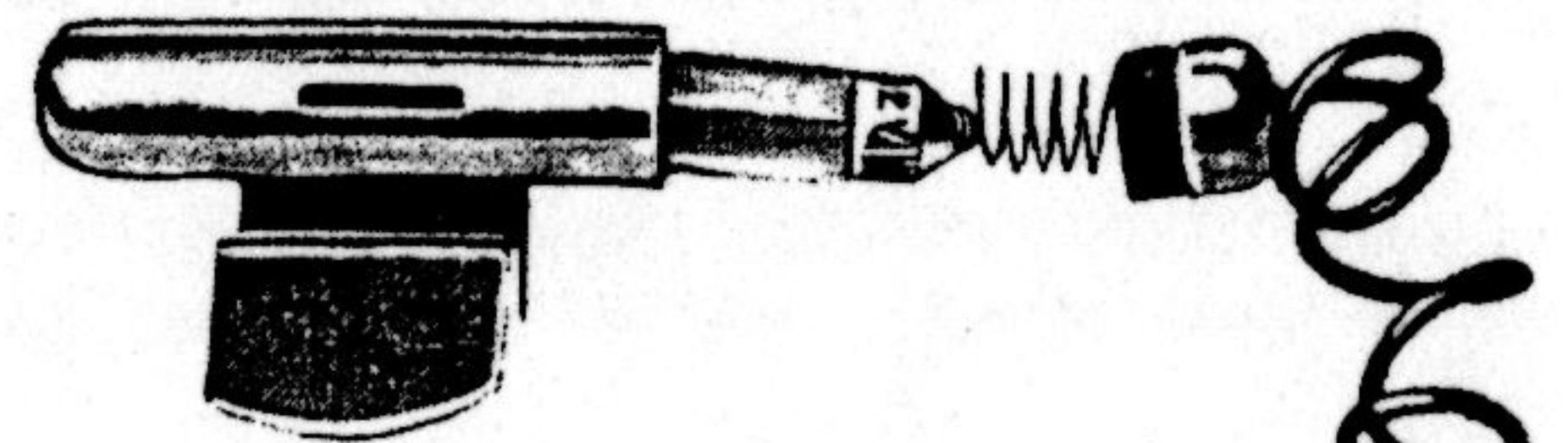

821

entier

821

Equipement Electrique

1039 - Compteur Complet avec Bloc adaptable pour Scooter modèle 52

1041 - Compteur Veglia Complet pour Scooter modèle 53 à 56

1042 - Bloc de Compteur nu

821 - Lampe d'éclairage du Compteur

768 - Faisceau d'éclairage 53/54

769 - > > 55/56

769A - > > Triporteur Vespa

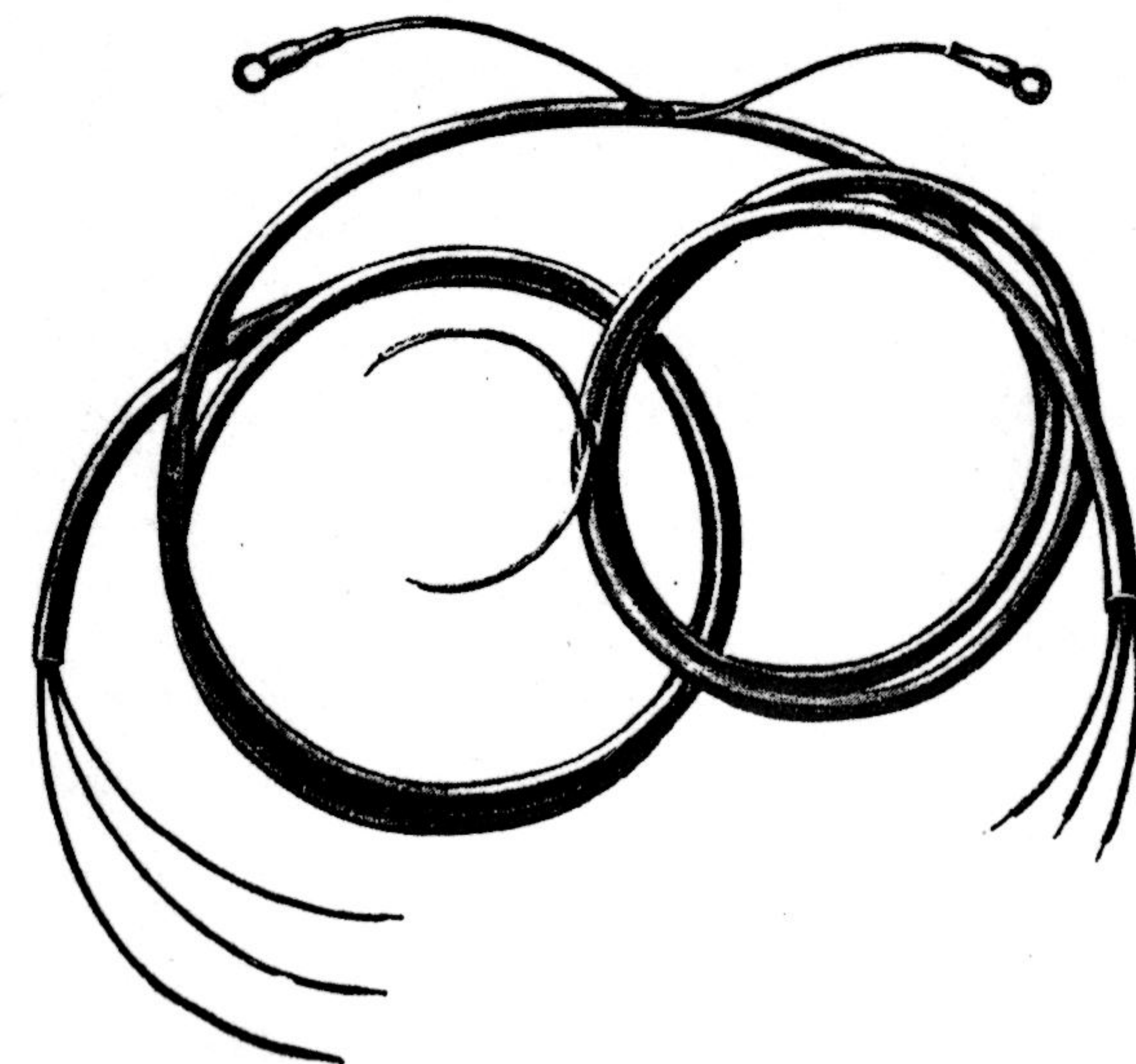
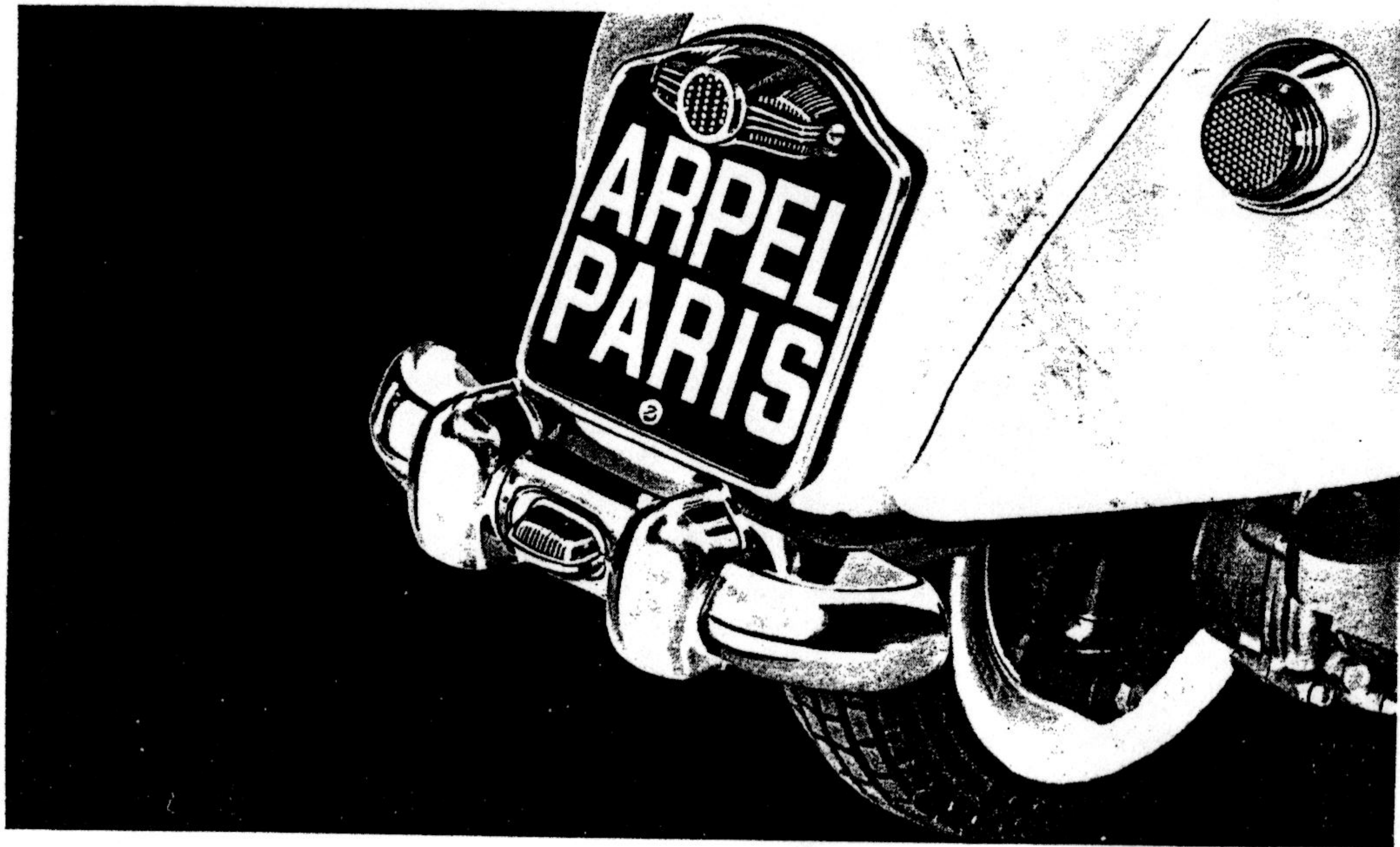

768
769
769 A

De la part de FAN DE SCOOTER



955
956

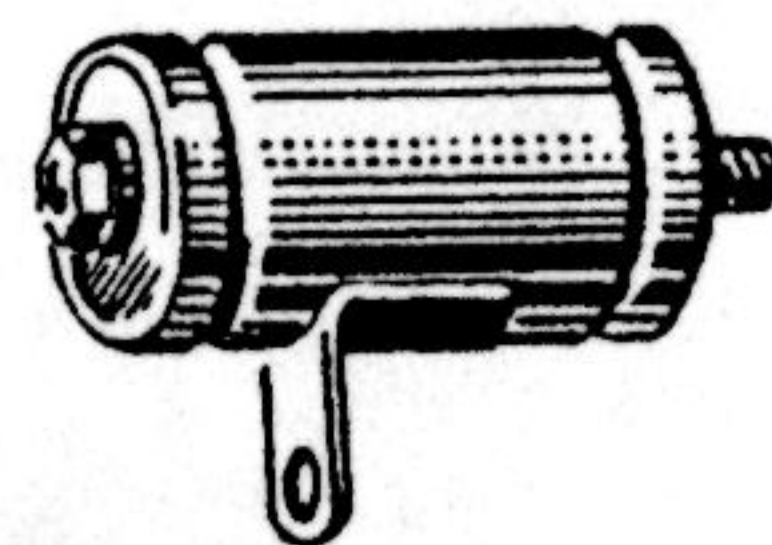

942

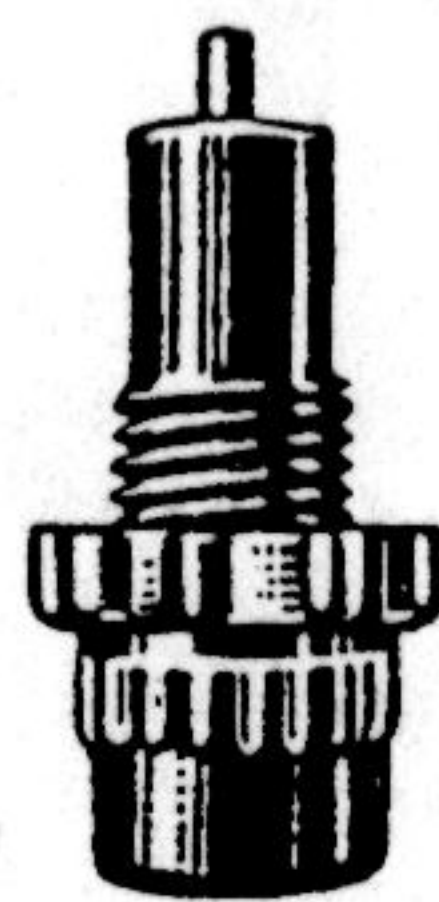

879

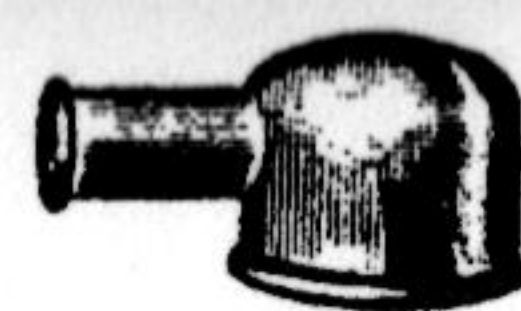

957

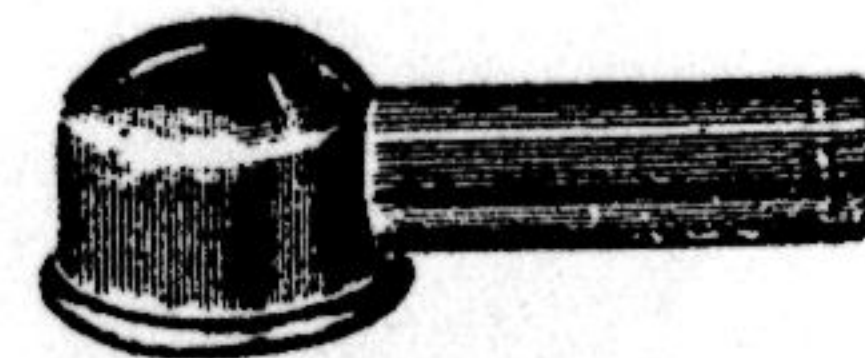

959

- 955 — Condensateur modèle 53
- 956 — » » 54, 55, 56
- 942 — Limiteur d'Intensité 6 volts
- 879 — Prise de Haute Tension
- 957 — Capuchon de Bougie, Petit Modèle
- 959 — » » Grand Modèle

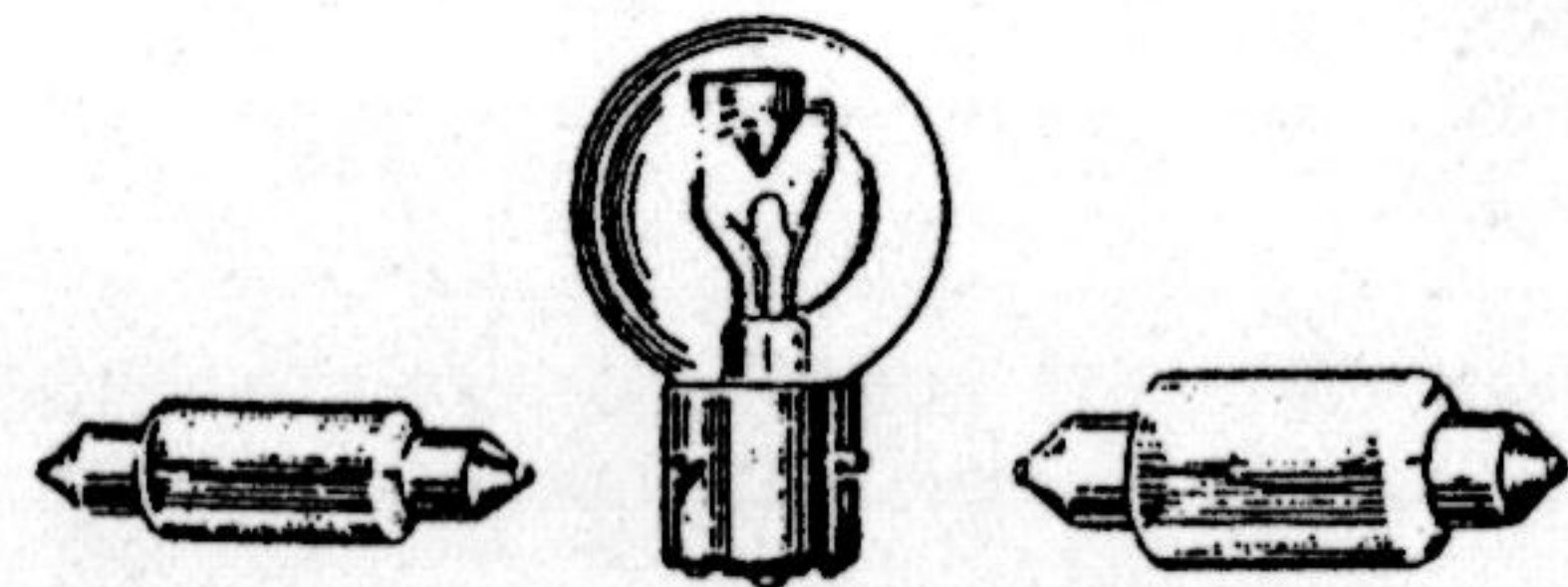

2028 à 2033

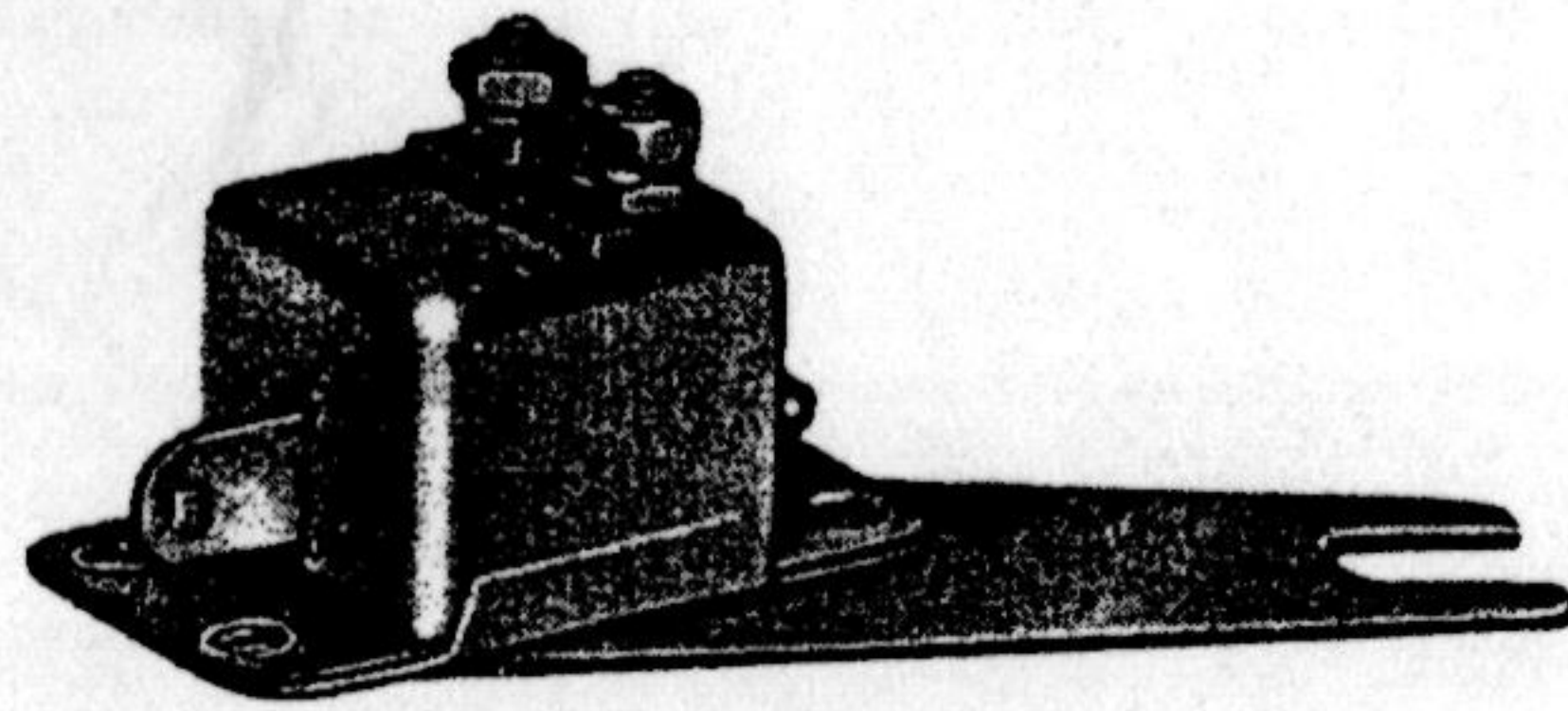

776

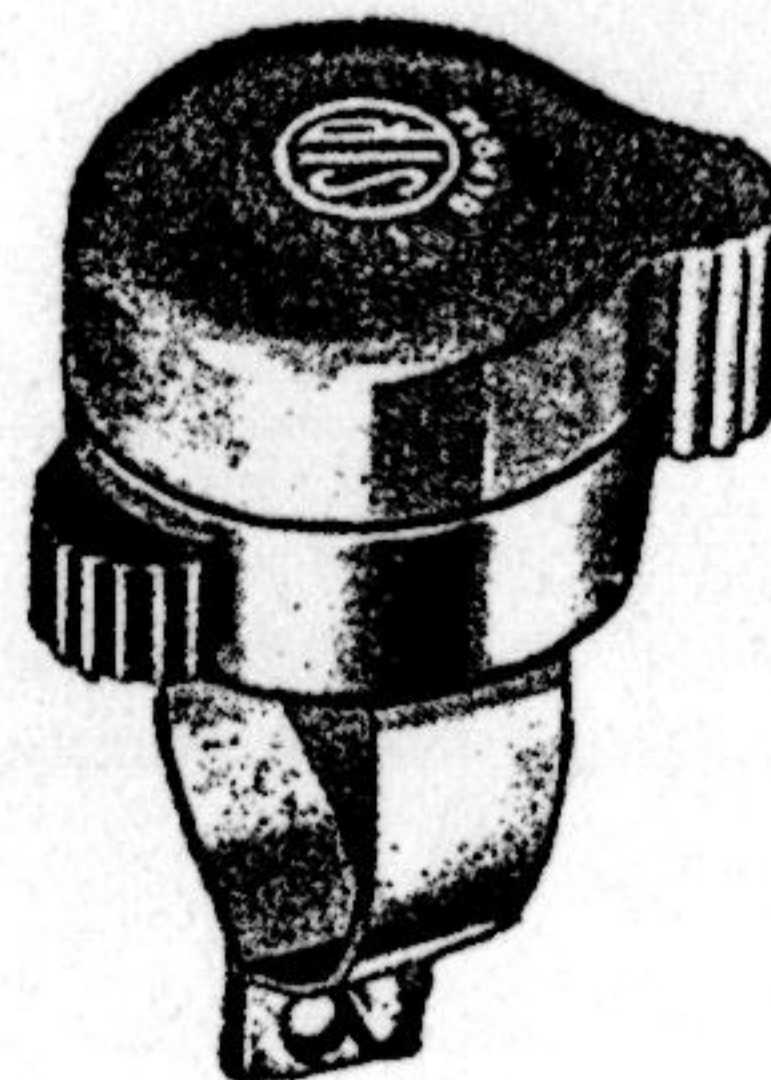

778

- 2028 — Lampe 6/36 Culot Bosch pour phare d'aile avant
- 2029 — Lampe Code jaune 6/25 Culot Bosch pour phare d'aile avant
- 2030 — Lampe Navette 6 volts 8/31
- 2031 — » » » 10/38
- 2032 — » » » 15 W 15/42
- 2033 — » Code jaune » 25/25
- 776 — Interrupteur Stop avec ressort
- 778 — Interrupteur de Clignoteur Spécial SIR 1000 Nouveau modèle, renforcé livré avec lampe

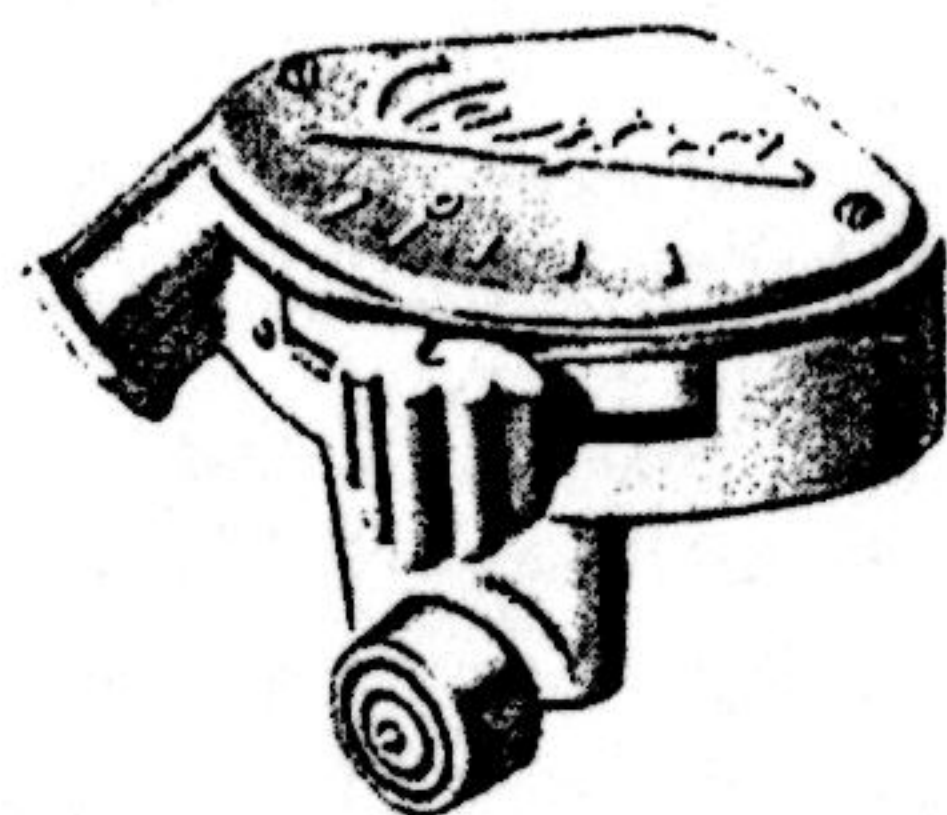

822

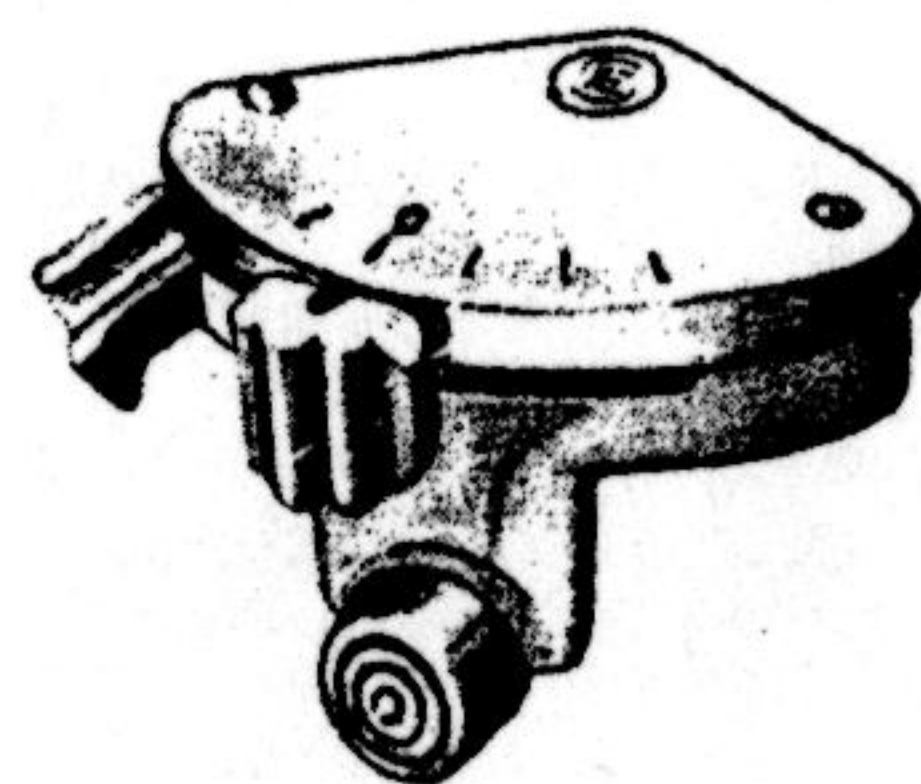

825

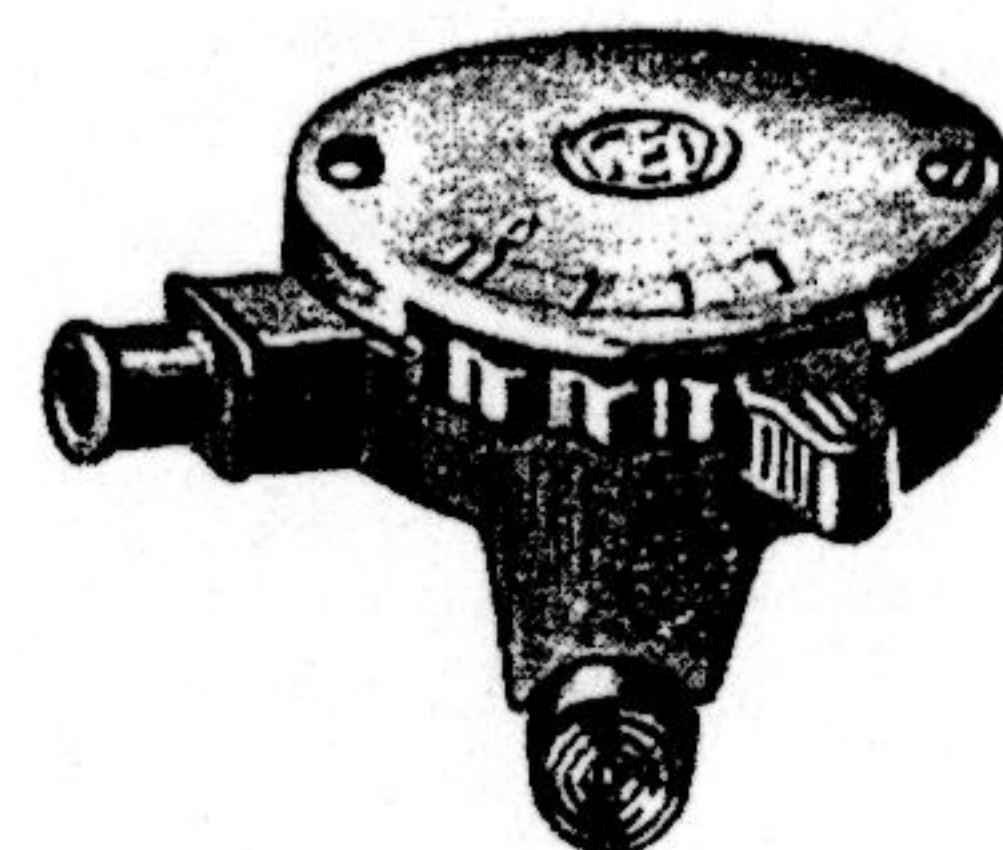

825 C

- 822 — Commutateur tous modèles avec Couvercle Bakélite
- 825 — Commutateur tous modèles avec Couvercle Chromé
- 825 C — Commutateur tous modèles avec Couvercle chromé. CEV Importation. Fixation à Vis

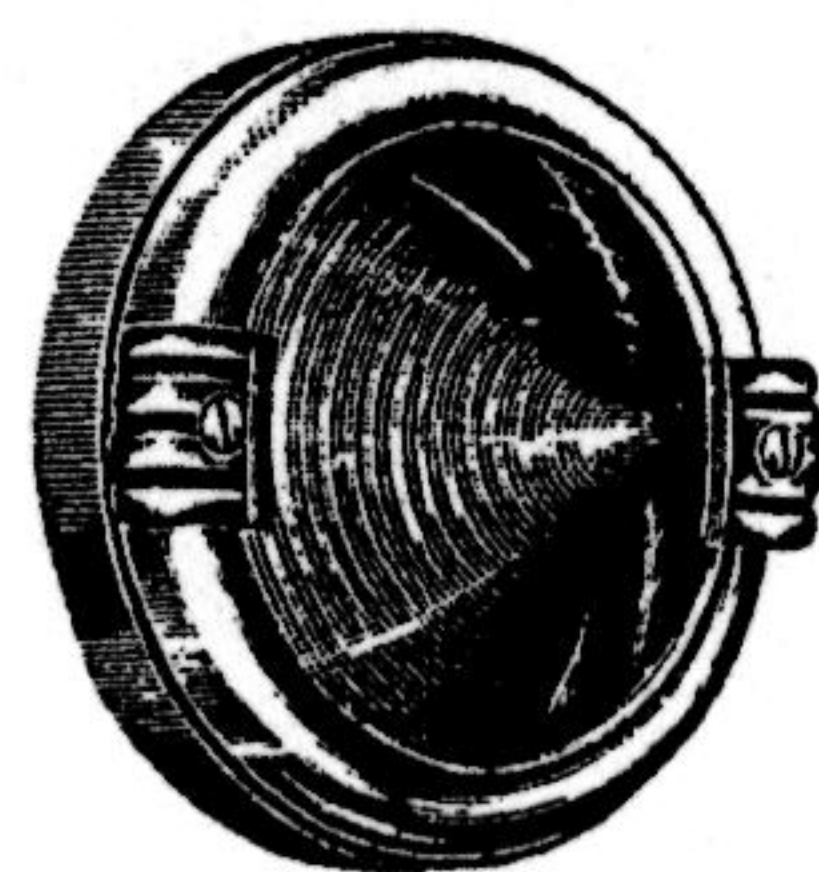

201 - 201 A
202 - 202 A

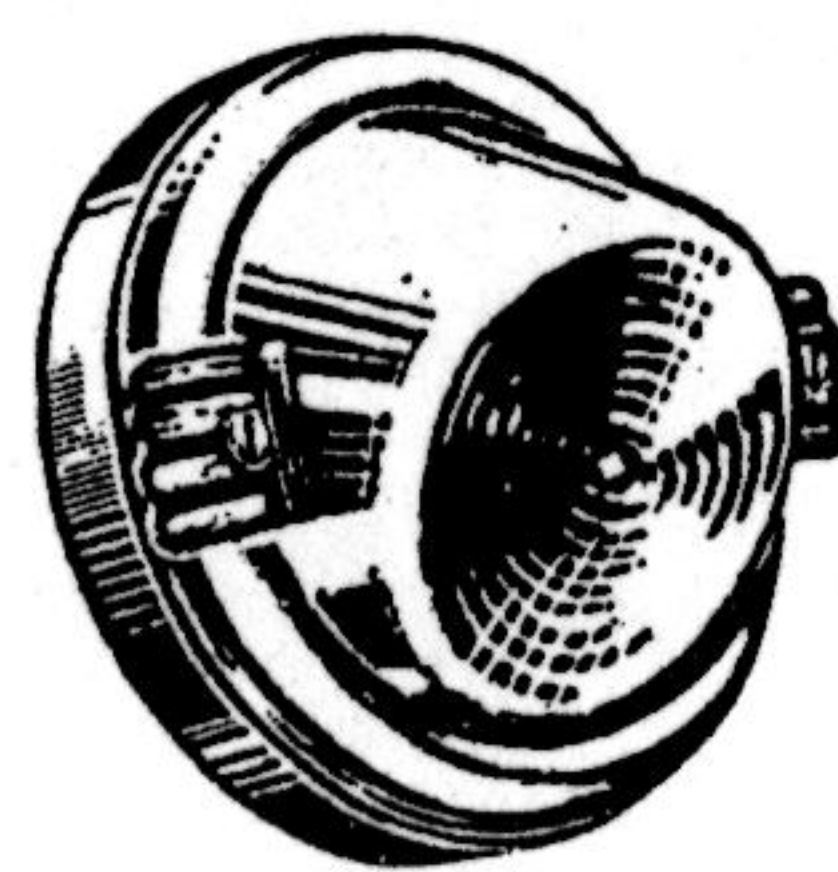

203 - 203 A

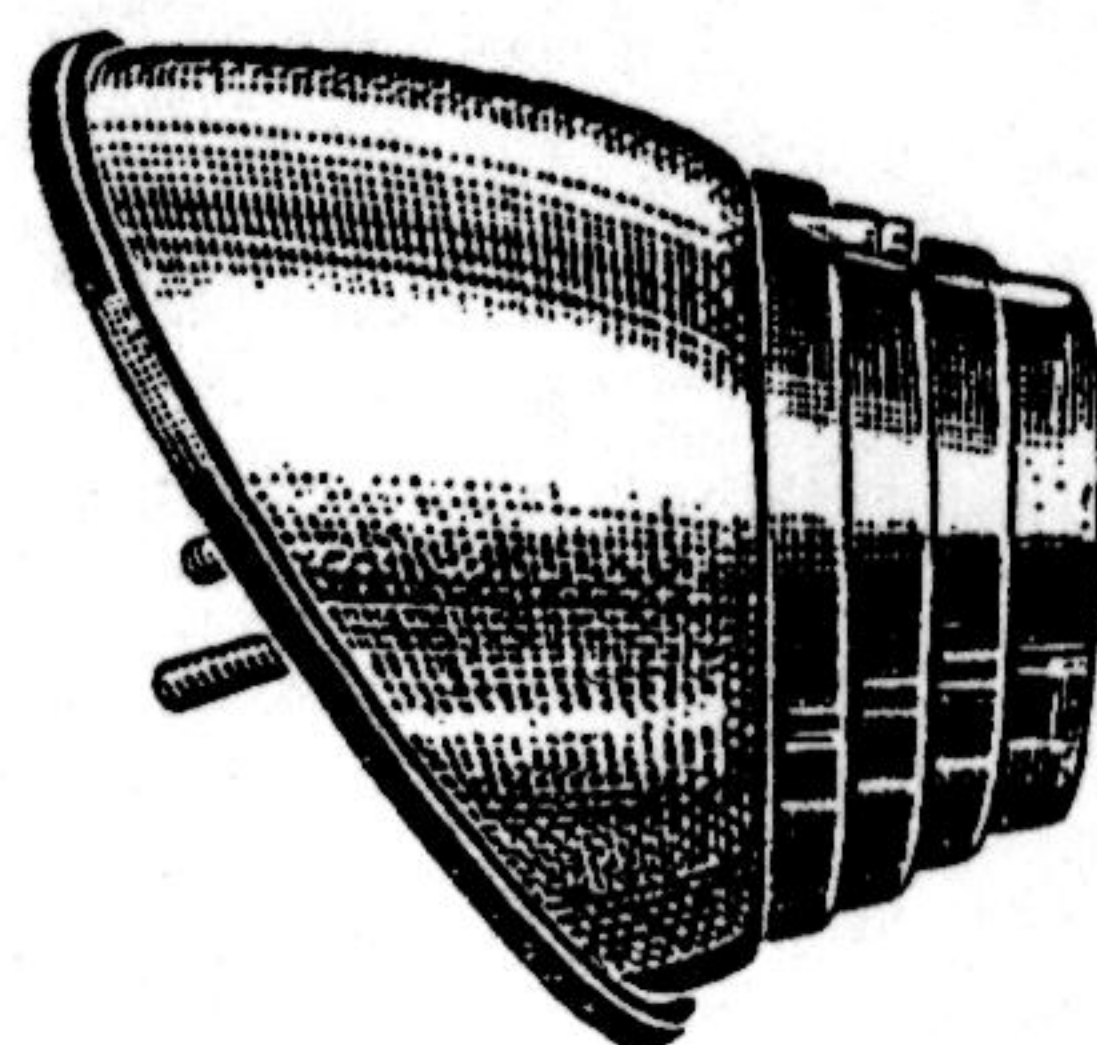

775 - 665

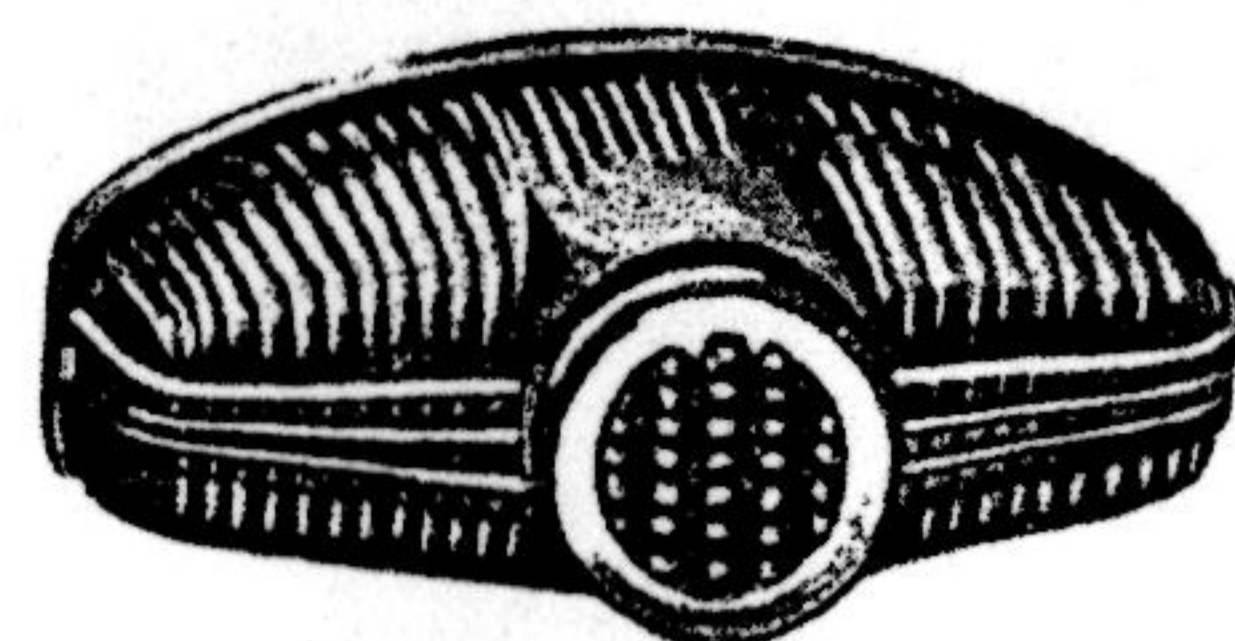

931 - 869
785 - 786

- 201 — Jeu de feux conique blanc
- 201A — Verre de rechange
- 202 — Jeu de Feux conique Rouge
- 202A — Verre de rechange
- 203 — Jeux de Feux incliné Rouge
- 203A — Verre de rechange
- 775 — Jeu de Feux Stop et Clignotant
- 665 — Verre de rechange
- 869 — Glace de Feu Arrière Autéroche 51 - 54
- 786 — » » » Maly 55 - 56
- 931 — Lanterne Arrière Autéroche 51-54 complète
- 785 — » » Maly 55-56 »

De la part de FAN DE SCOOTER

Cibié, Modèle 54/55

Auteroche Modèle 52

870
870A
870B

- 895 - Glace de Phare, Cibié
- 896 - » » Auteroche
- 876 - Porte de Phare Auteroche, à Visière, Modèle 56
- 877 - Porte de Phare Auteroche, sans Visière, Modèle 54/55
- 877/52 - Porte de phare Auteroche, Modèle 52
- 897 - » » Cibié, à Visière, Modèle 56
- 878 - Porte de Phare Cibié, sans Visière, Modèle 54/55
- 857 - Phare d'Aile Avant Emaillé, Complet
- 719 - Enjoliveur de Phare d'Aile Avant
- 720 - Glace de Phare d'Aile Avant
- 721 - Porte de Phare d'Aile Avant
- 722 - Réflecteur de Phare d'Aile Avant
- 723 - Porte-Lampe de Phare d'Aile Avant
- 724 - Agrafe

895
896

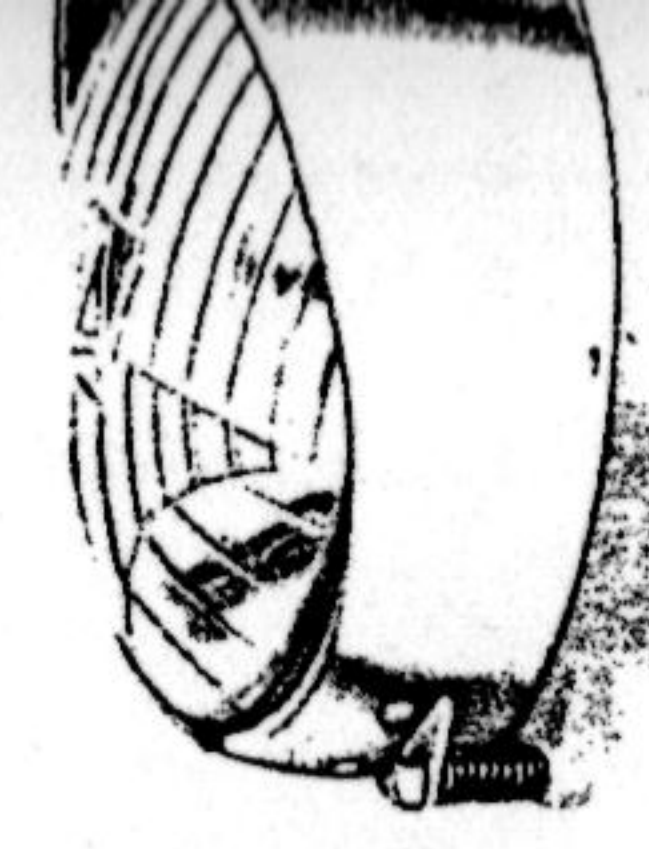

870
870 A
870 B

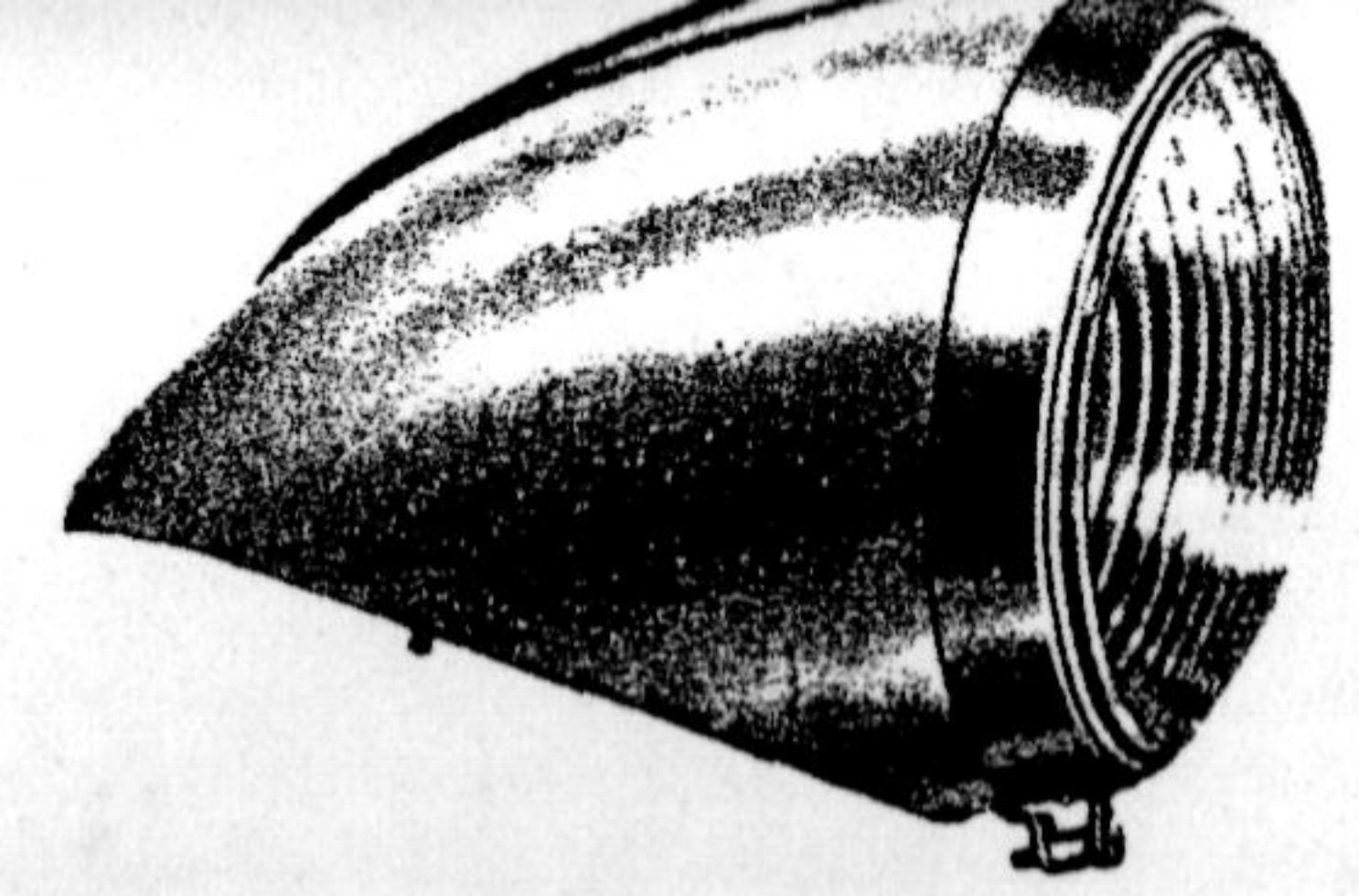

857

876
877
877-52
897
878



719

720



721

722



724

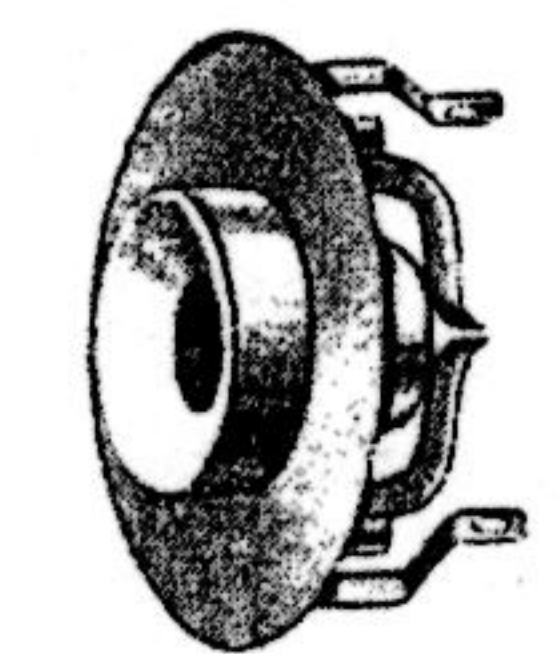

723

- 874 - Porte-Lampe Auteroche avec Veilleuse
- 875 - » » Cibié » »
- 881 - Réflecteur de Phare Auteroche
- 882 - Réflecteur de Phare Cibié
- 850 - Visière de Phare Grand Modèle, Laiton chromé
- 850A - Visière de Phare Modèle 56, Laiton chromé avec Voyant Rouge

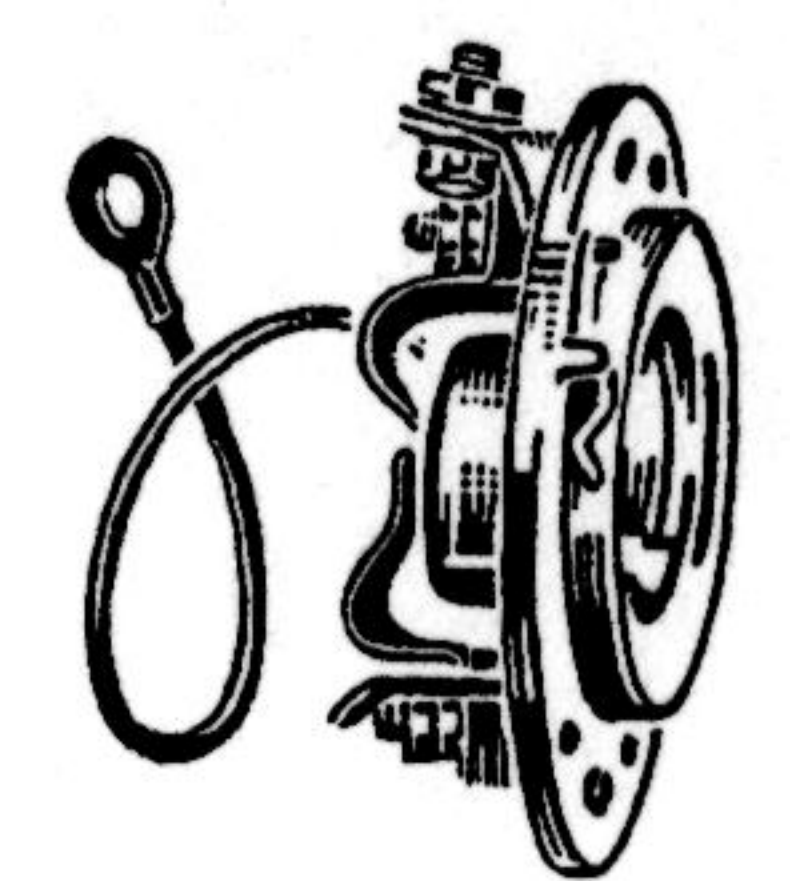

874 - 875

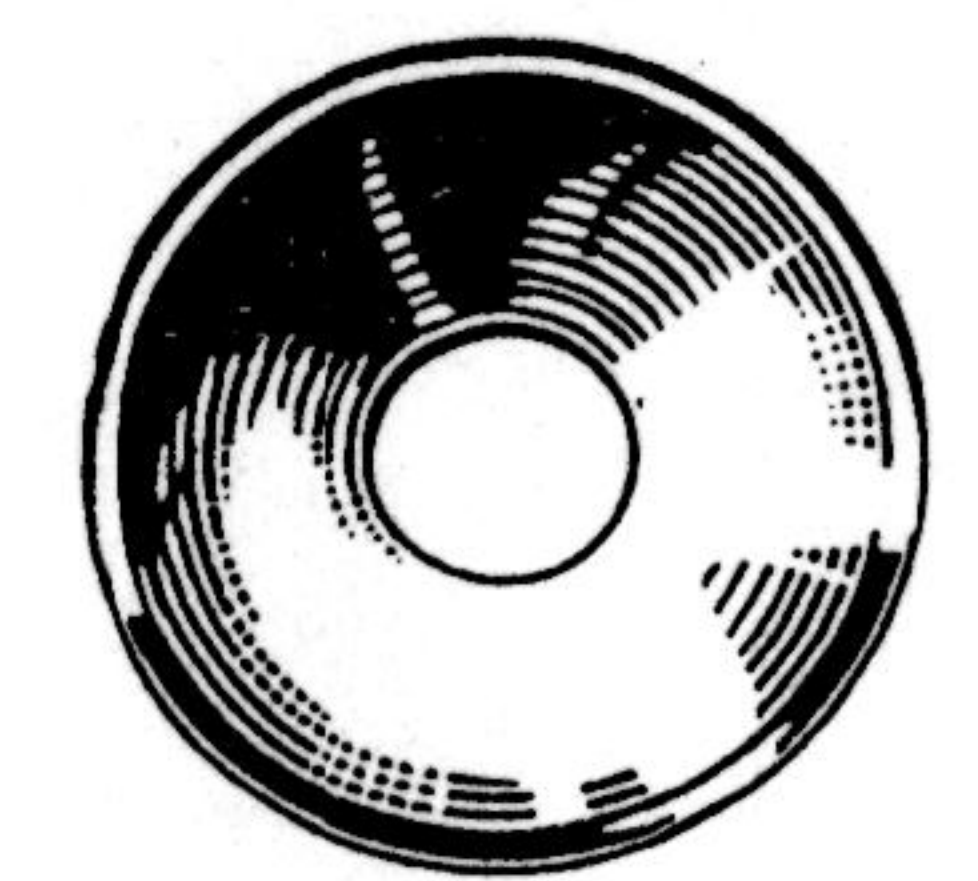

881 - 882

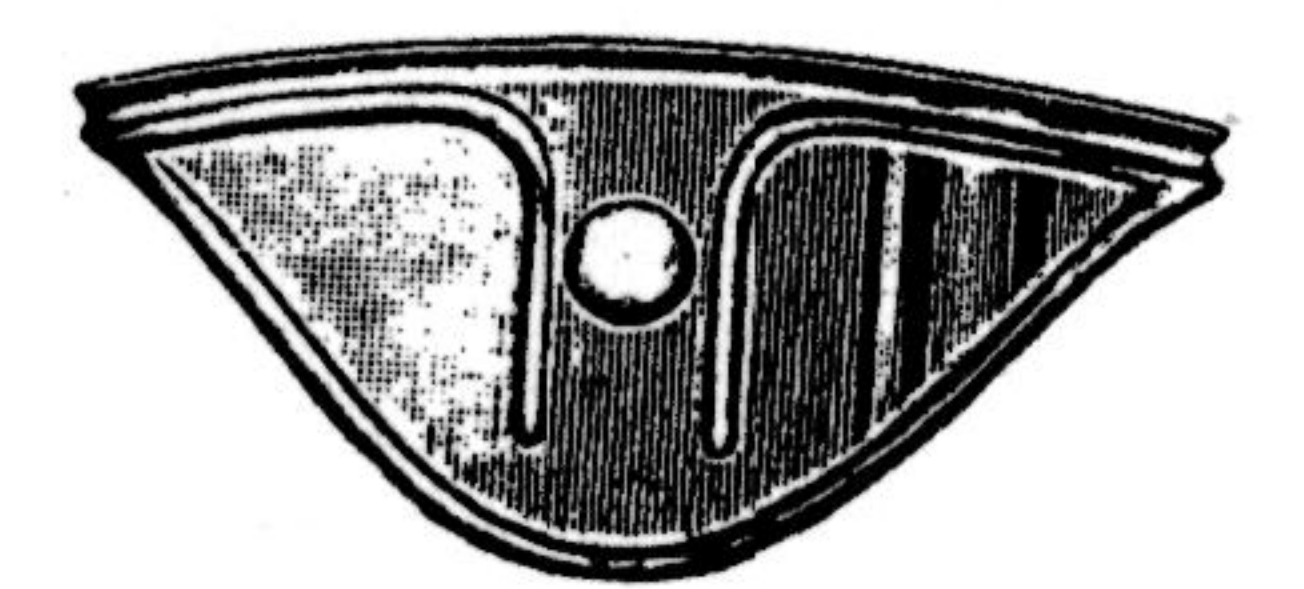

850 - 850 A

De la part de FAN DE SCOOTER

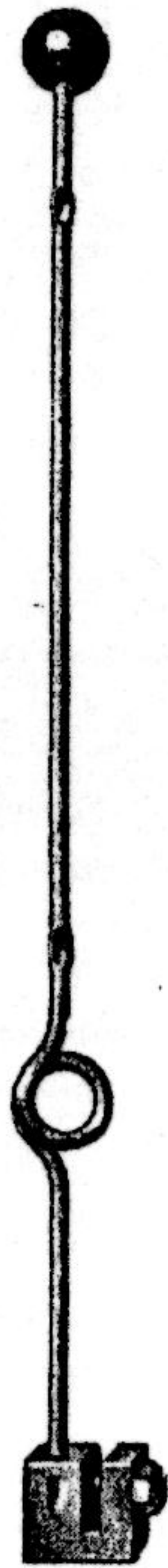

809

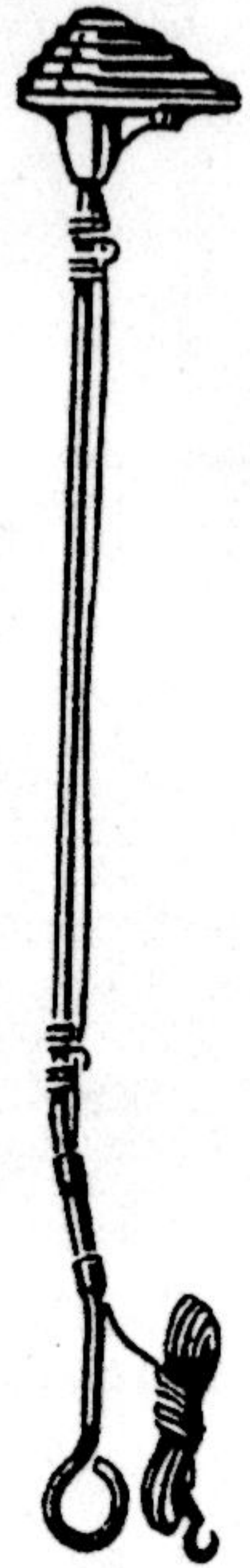

939



938



934



922



770 A

770 A

770

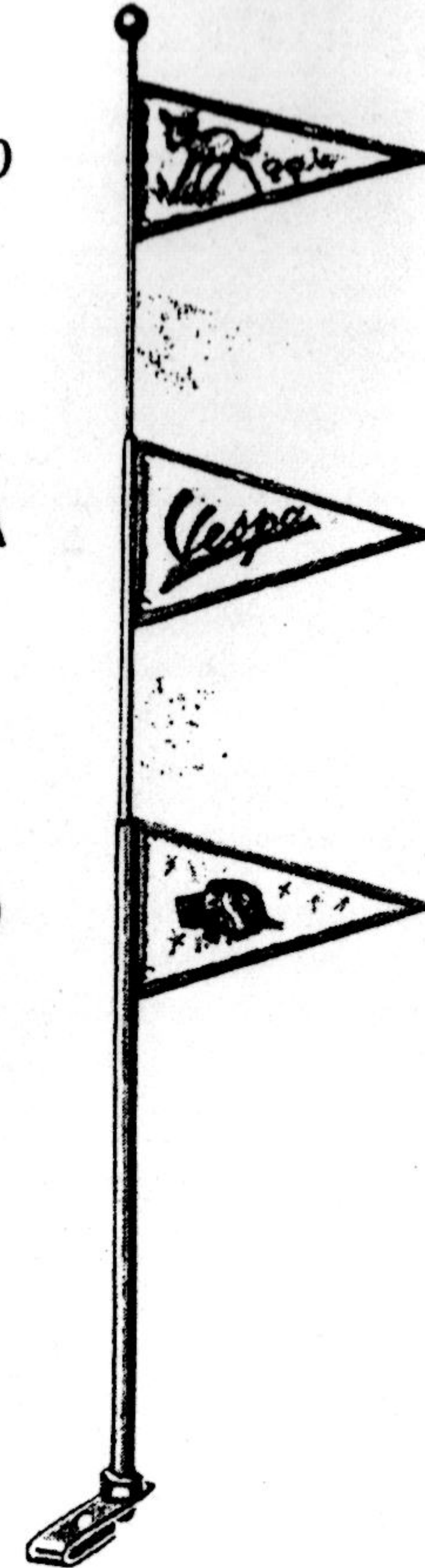

935

809 - Porte-Fanion luxe

939 - Porte - Fanion avec motif éclairé

938 - Porte - Fanion avec tête d'indien éclairée

934 - Motif d'aile AV tête d'indien éclairée

922 - Porte-Fanion, grand luxe à ressort

935 - Porte-Fanion, grand modèle télescopique

770 - Fanion avec motifs Walt Disney divers

770A- Fanion Vespa



804

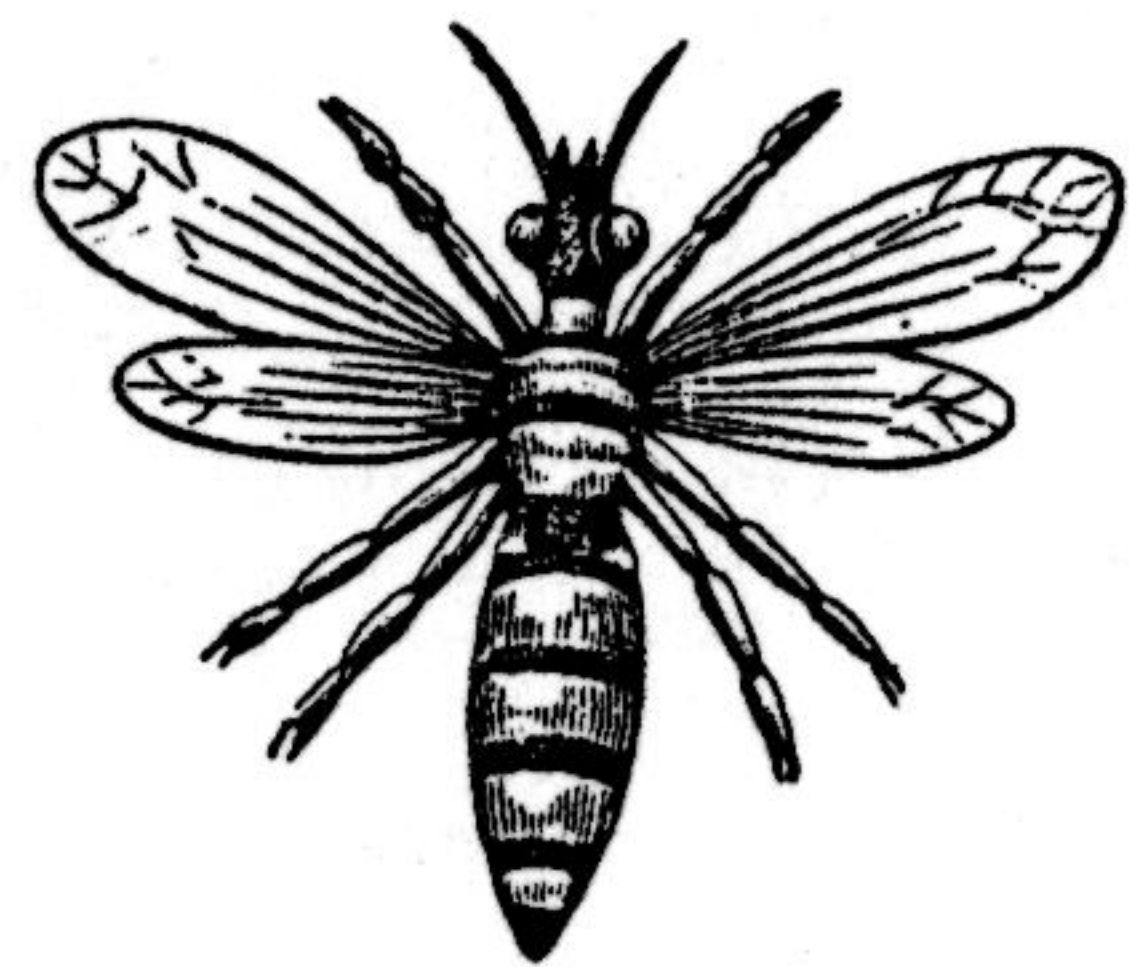

886

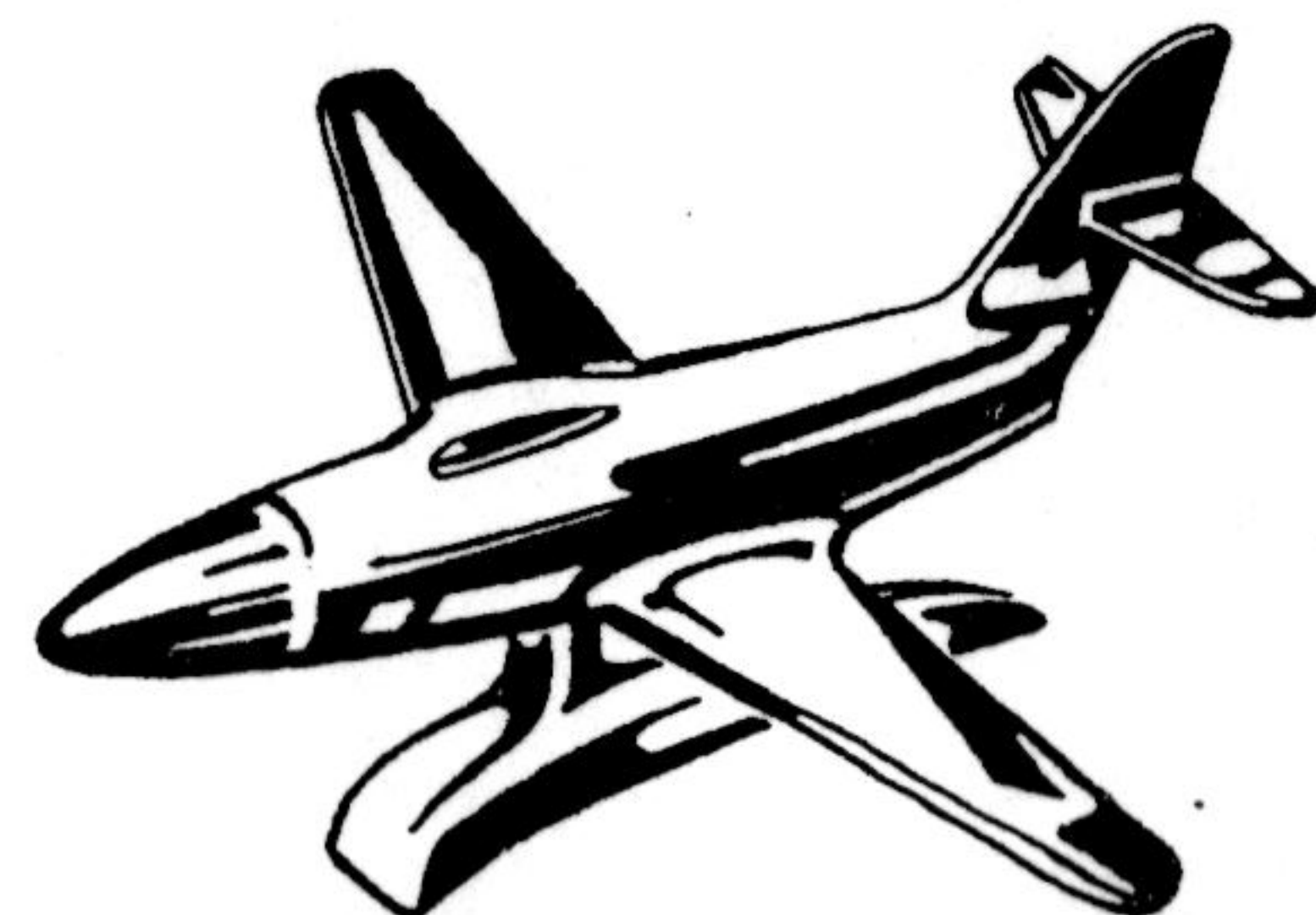

905

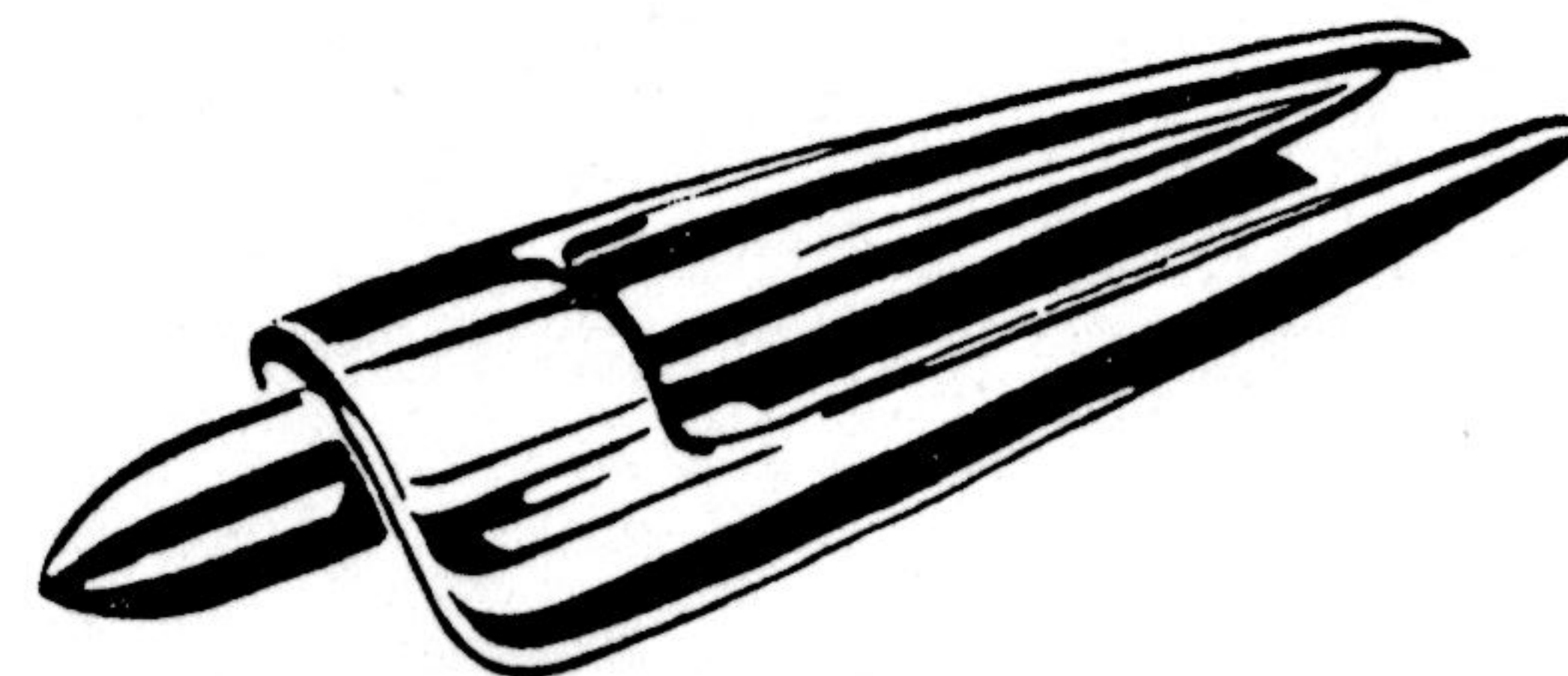

970

804 - Lettre F nylon, noir sur fond blanc

886 - Guêpe décorative caoutchouc

905 - Motif d'aile AV avion chromé

970 - Motif d'aile AV Hirondelle grand luxe chromé.

Caps

847 Caps...
848 Caps...
849 Caps...
850 Caps...

Profiles

747 Profile...
748 Profile...
749 Profile...
750 Profile...

Straps

971 Straps...
972 Straps...

Buckles

843 Buckles...
843 A Buckles...

780 Buckles...
977 Buckles...

843 Buckles...

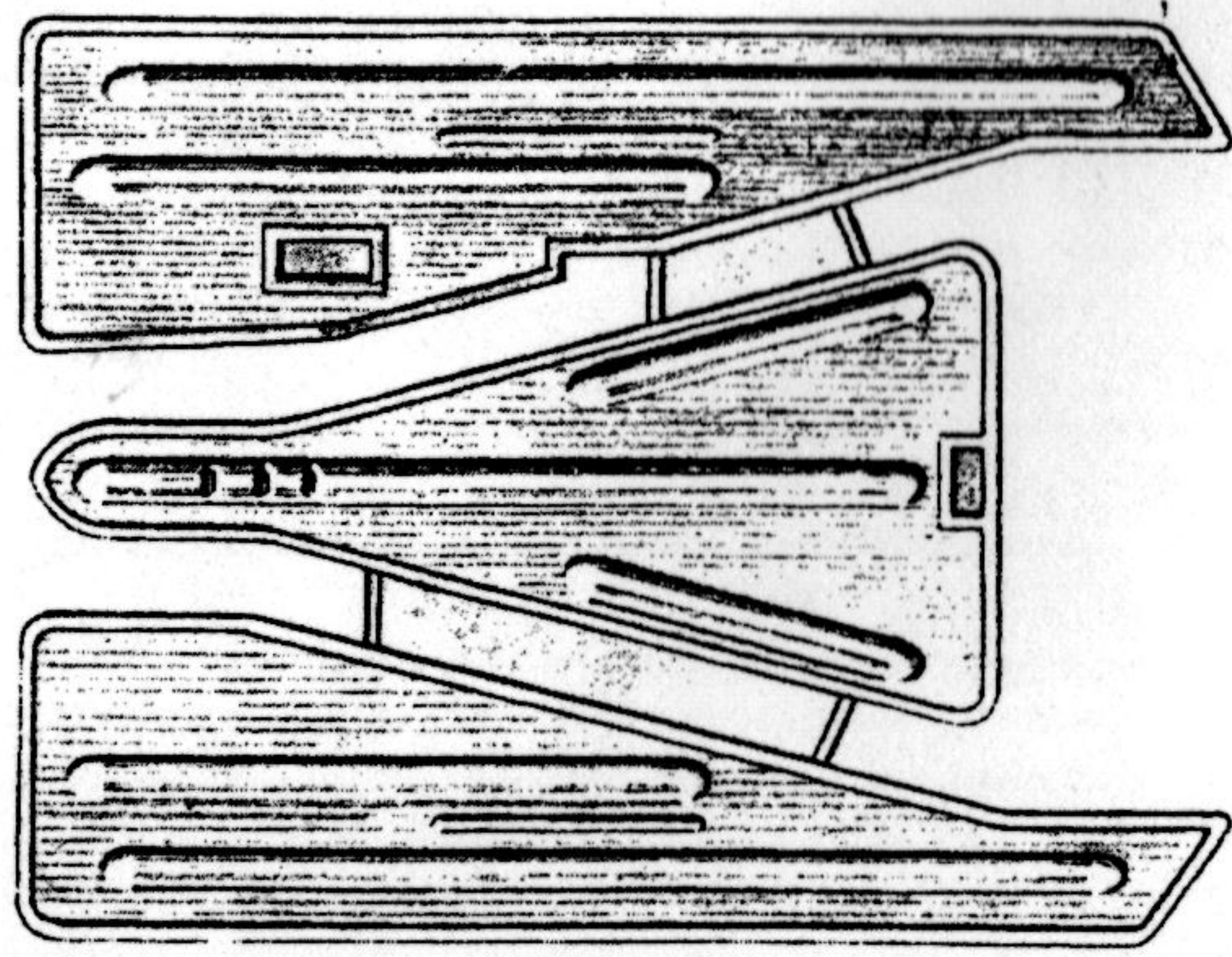

847

747

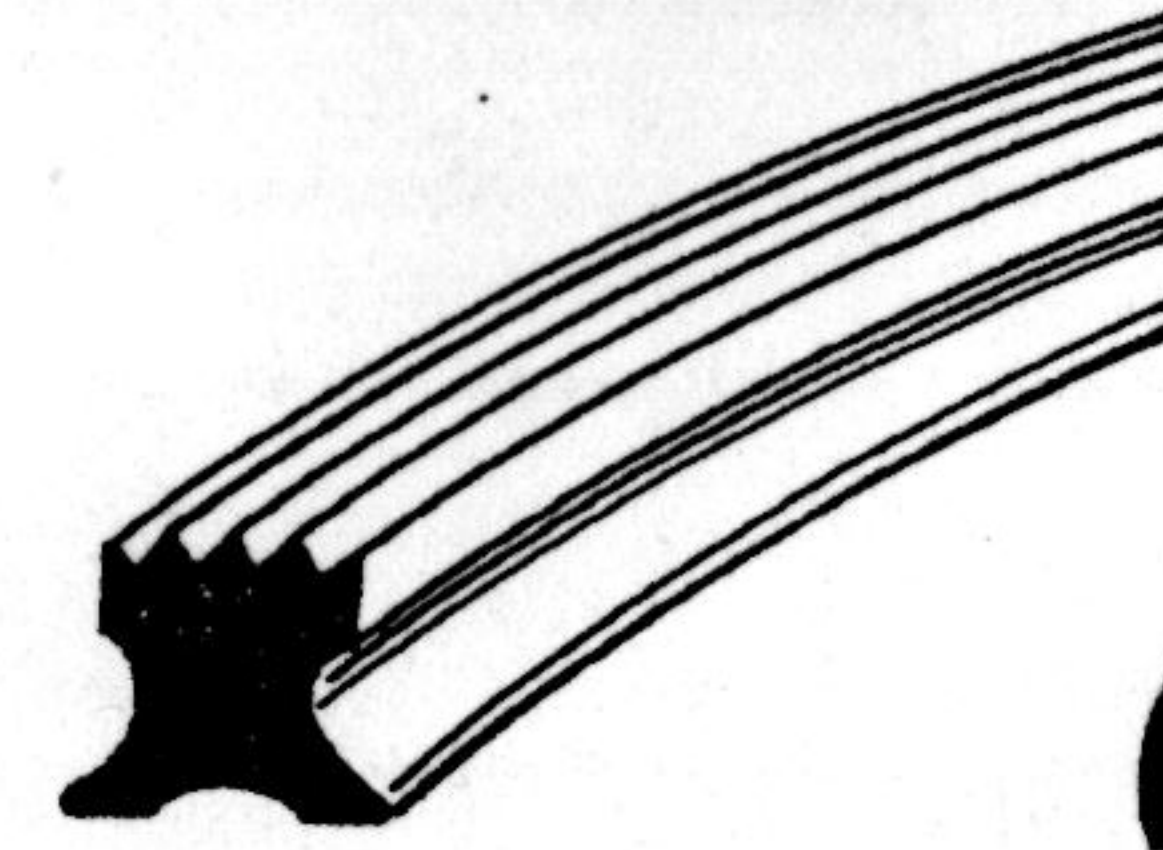
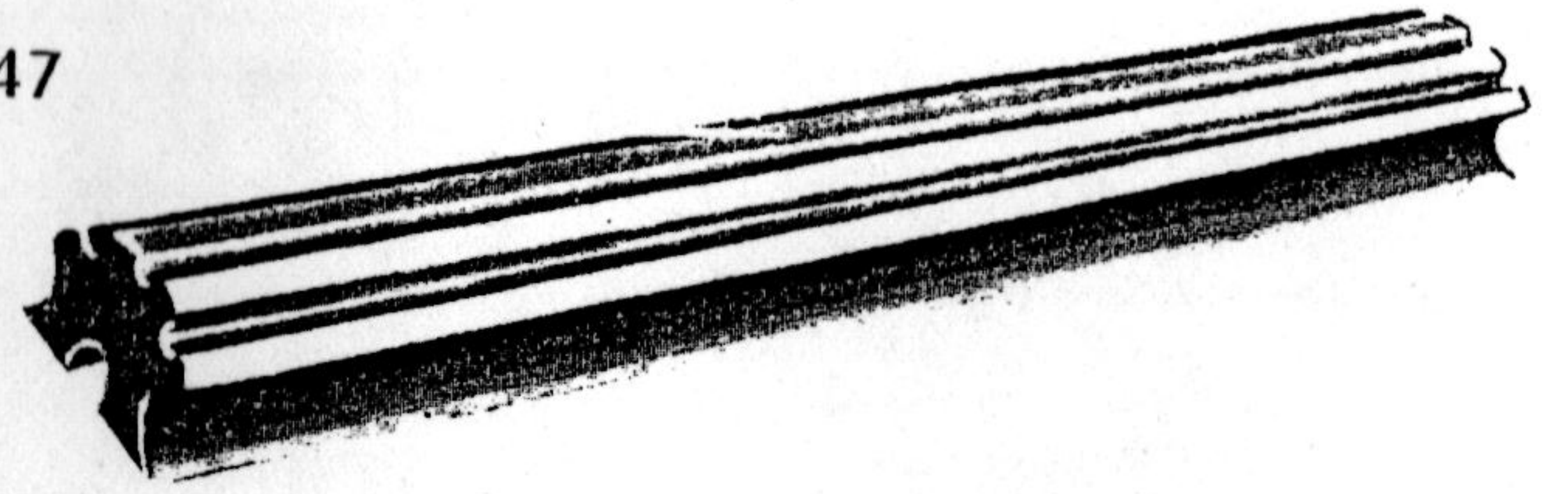

748

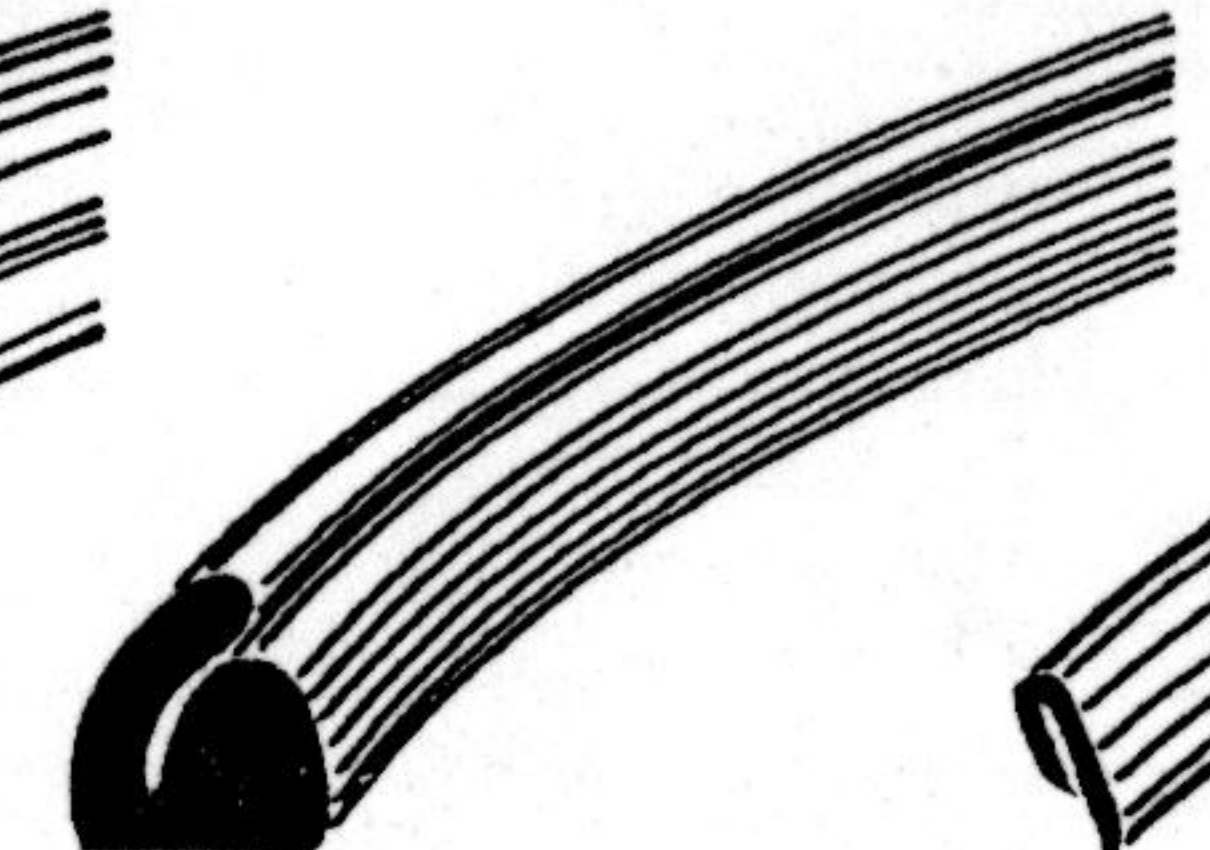

749



736

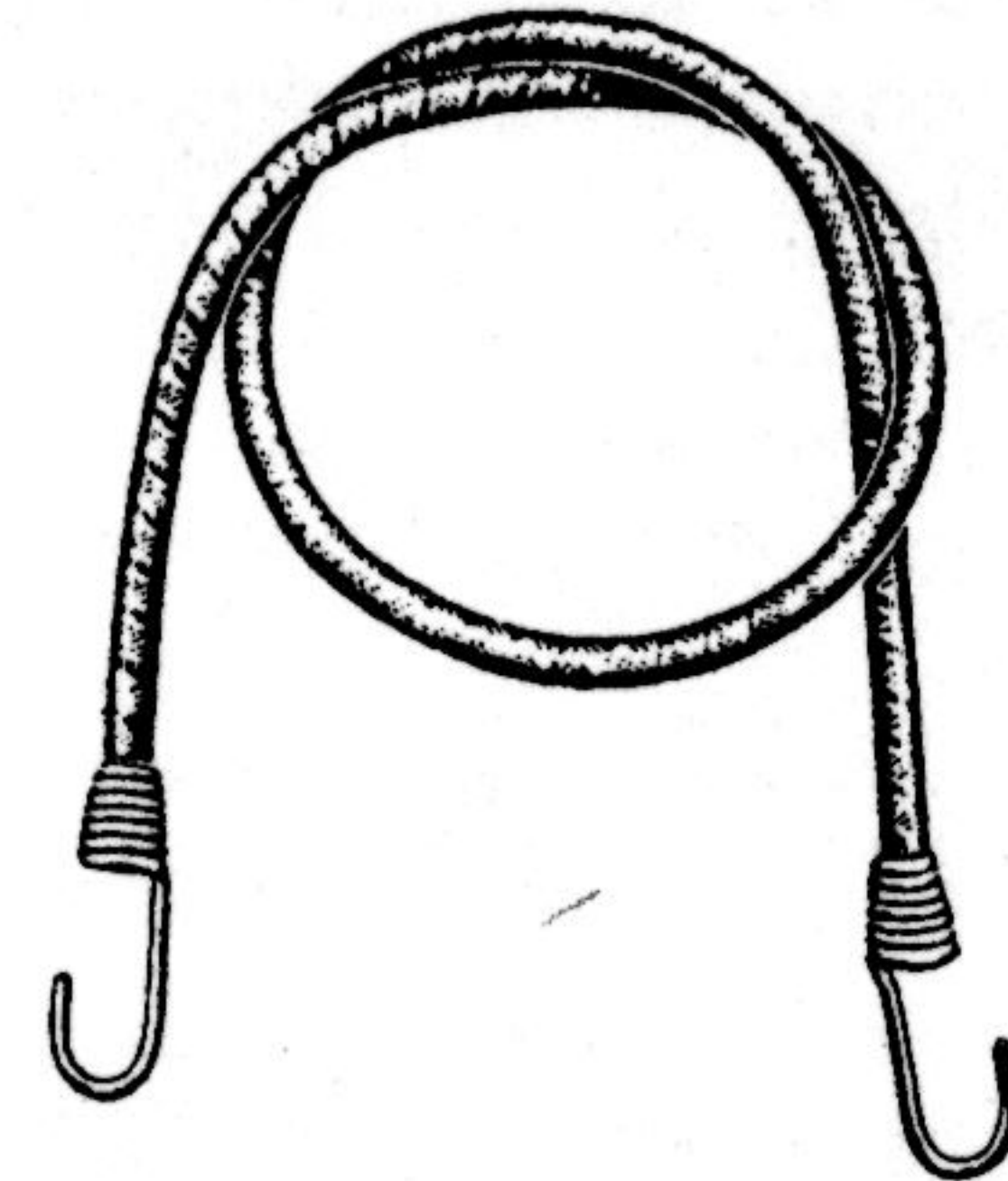

971

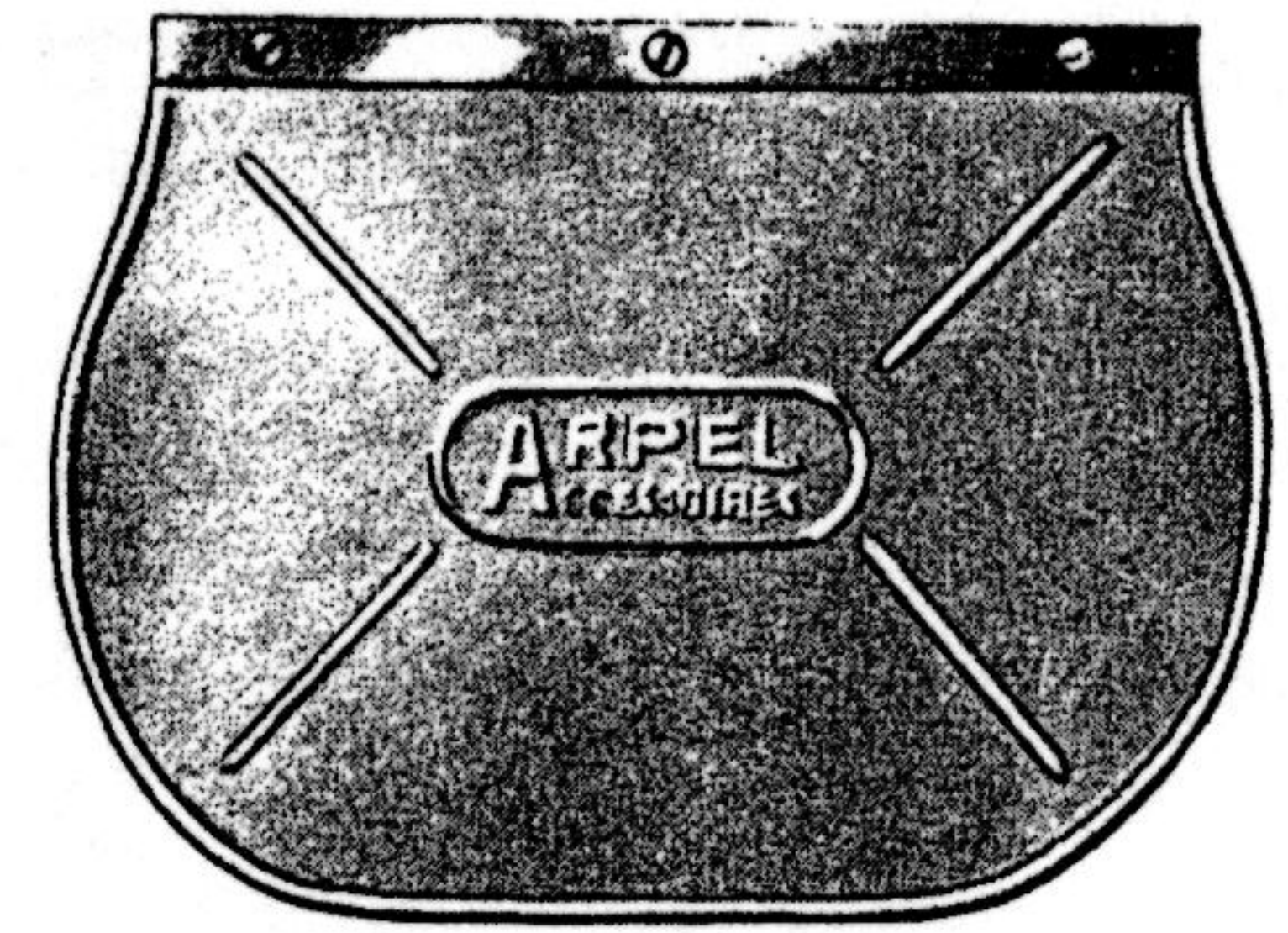

932

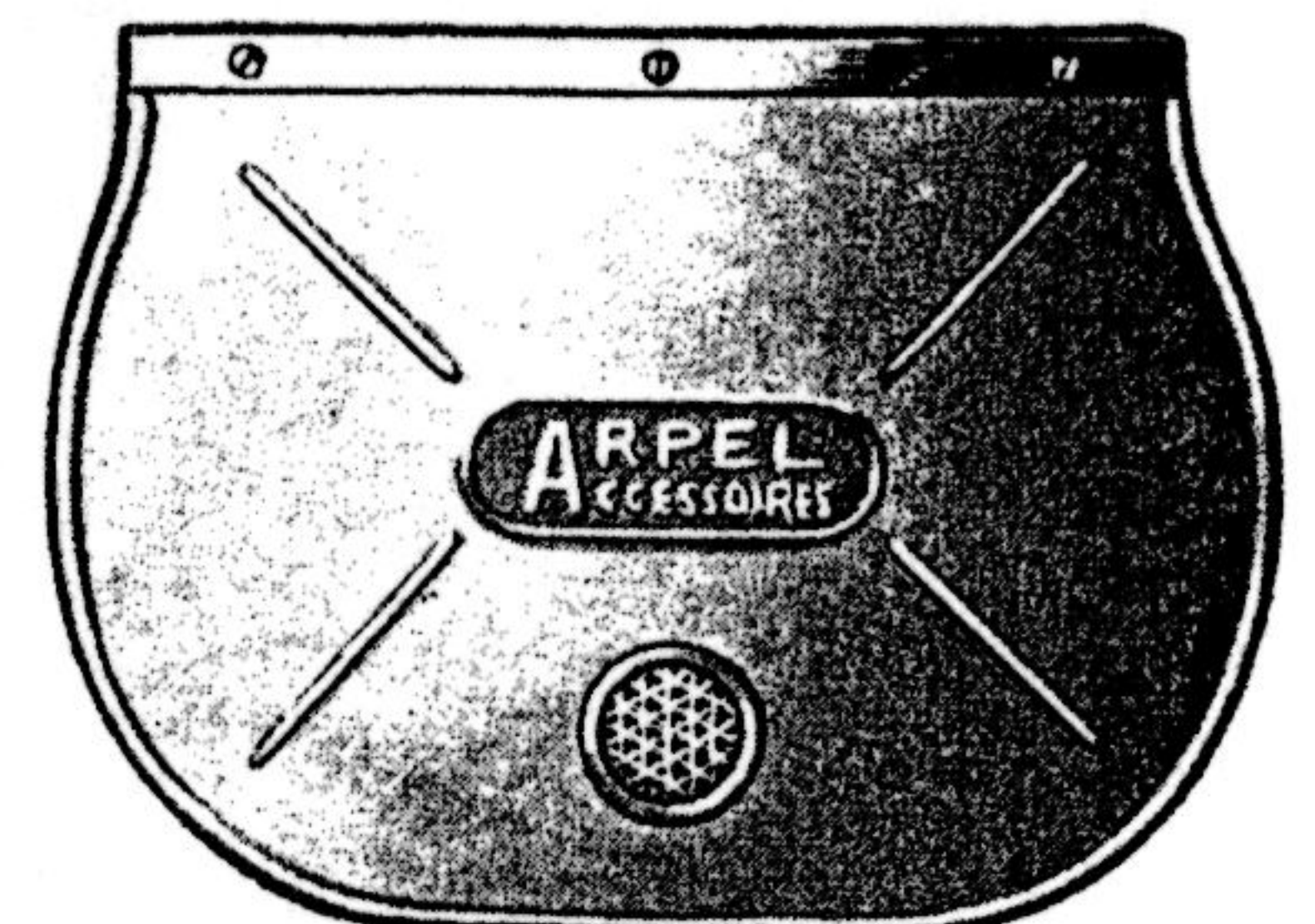

929

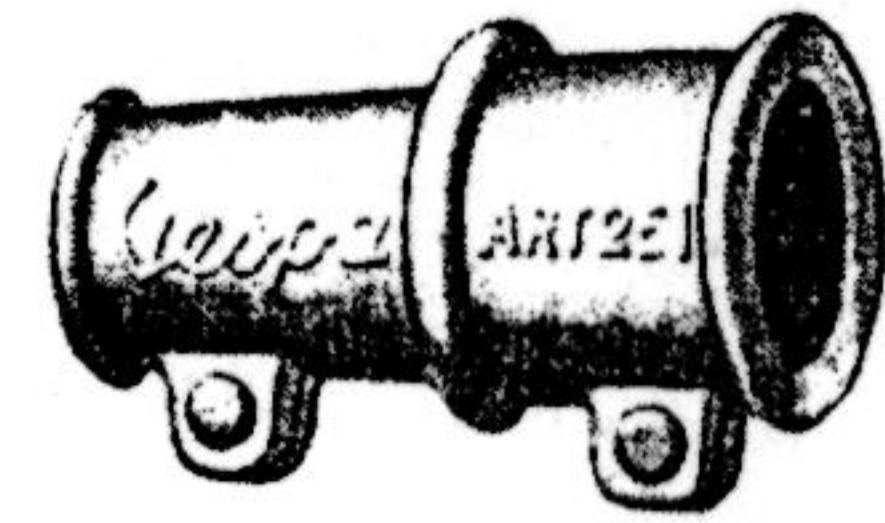

780

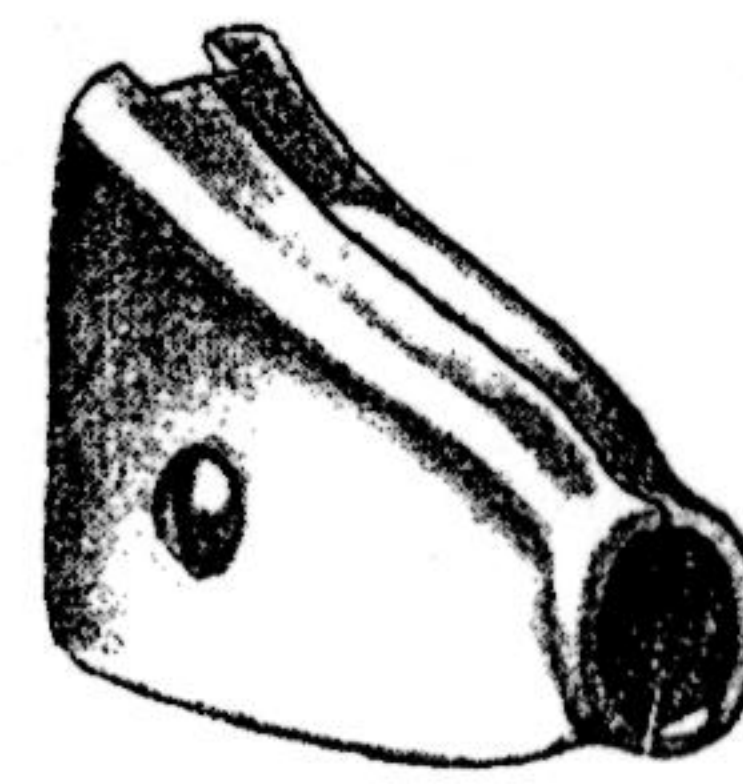

977

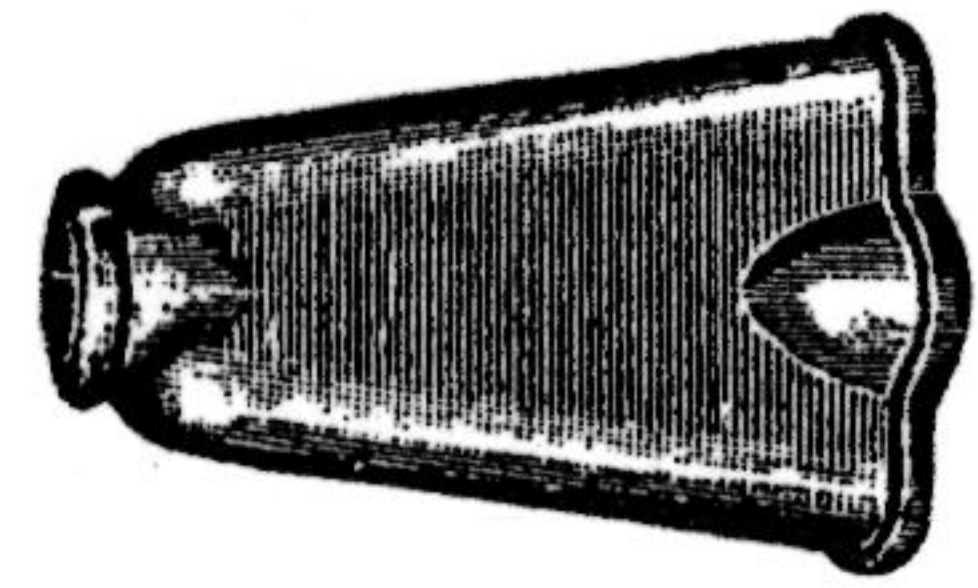

843

843 A

De la partie
FAN DE S



802
 802 A

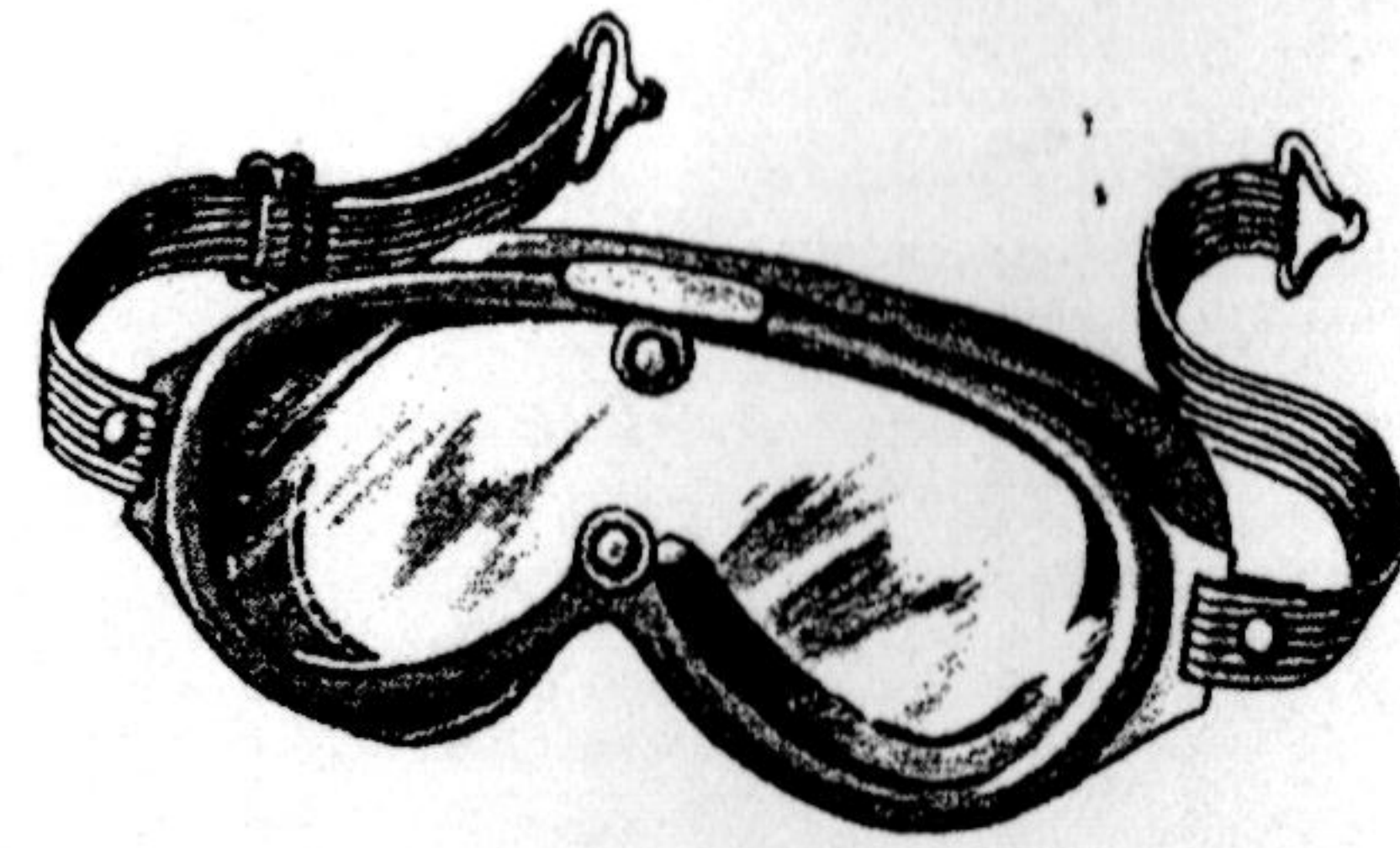

904

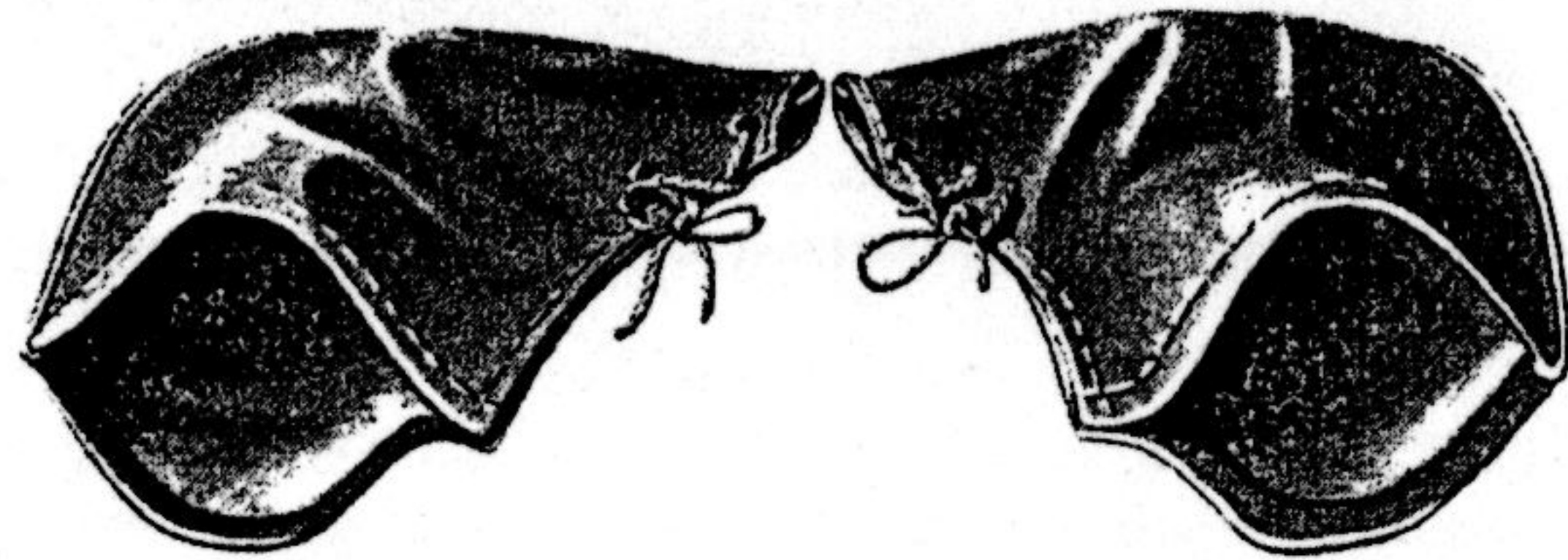

923

930

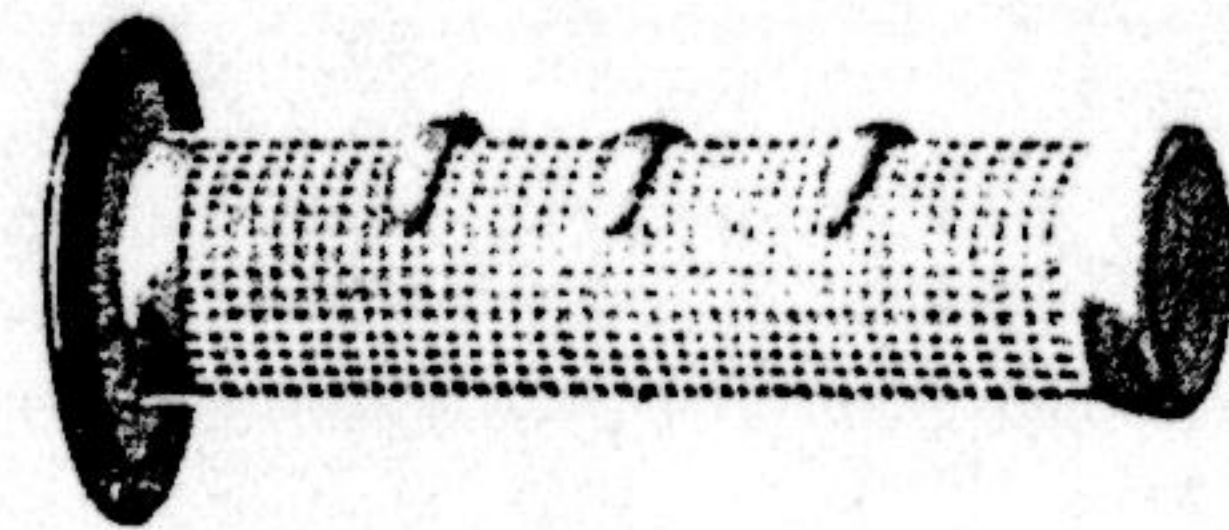

762

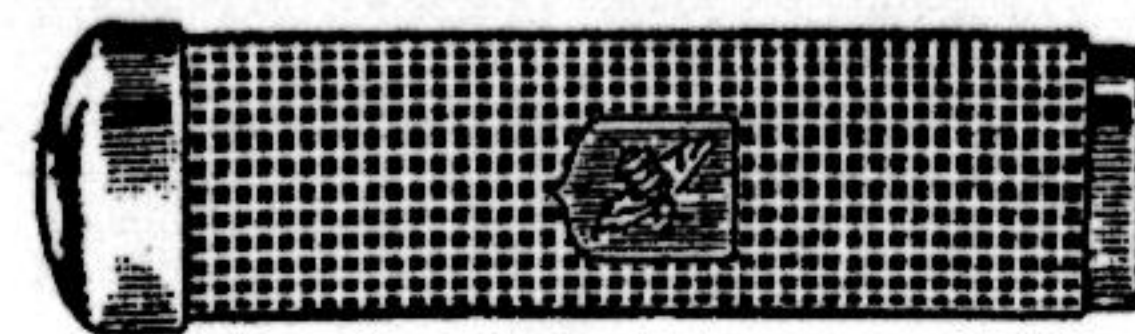

865

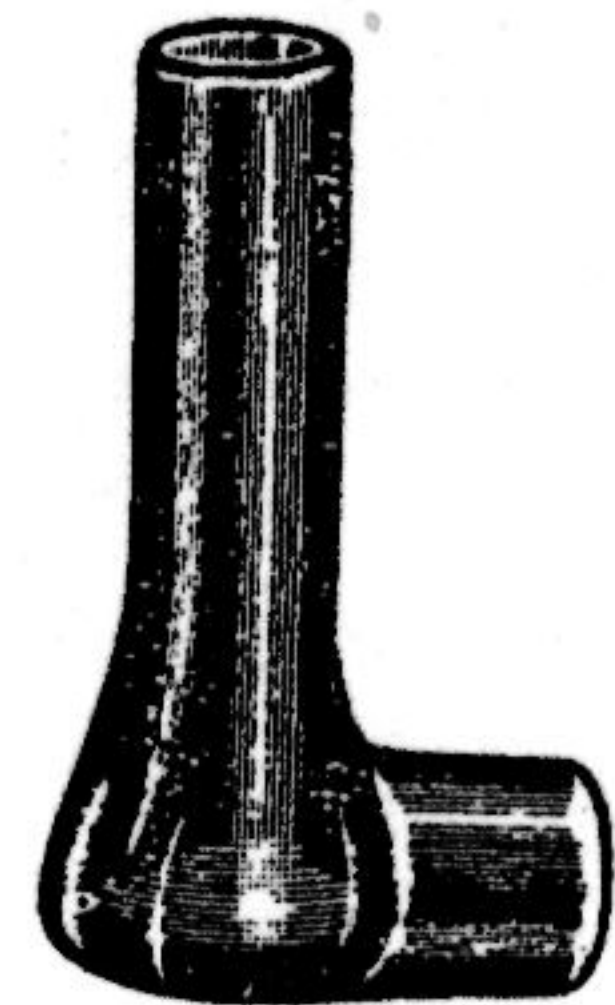
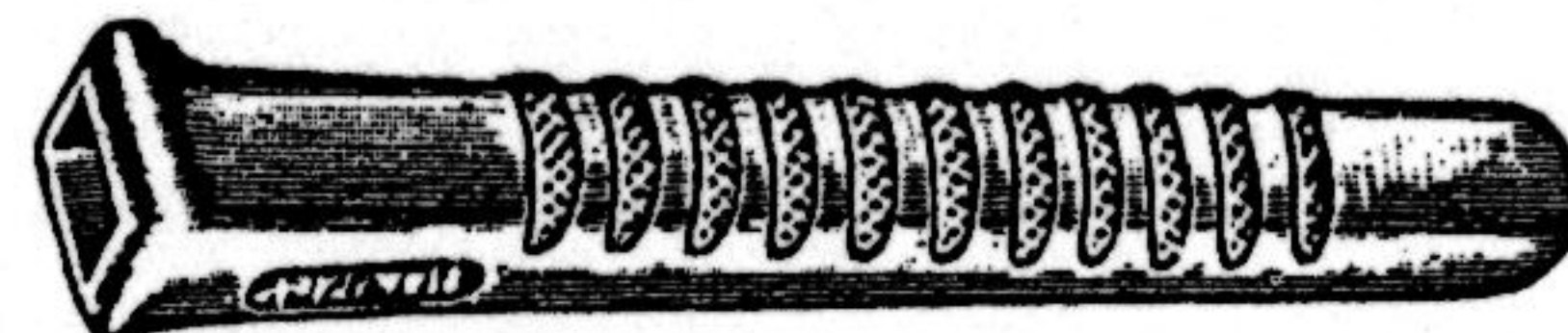

760

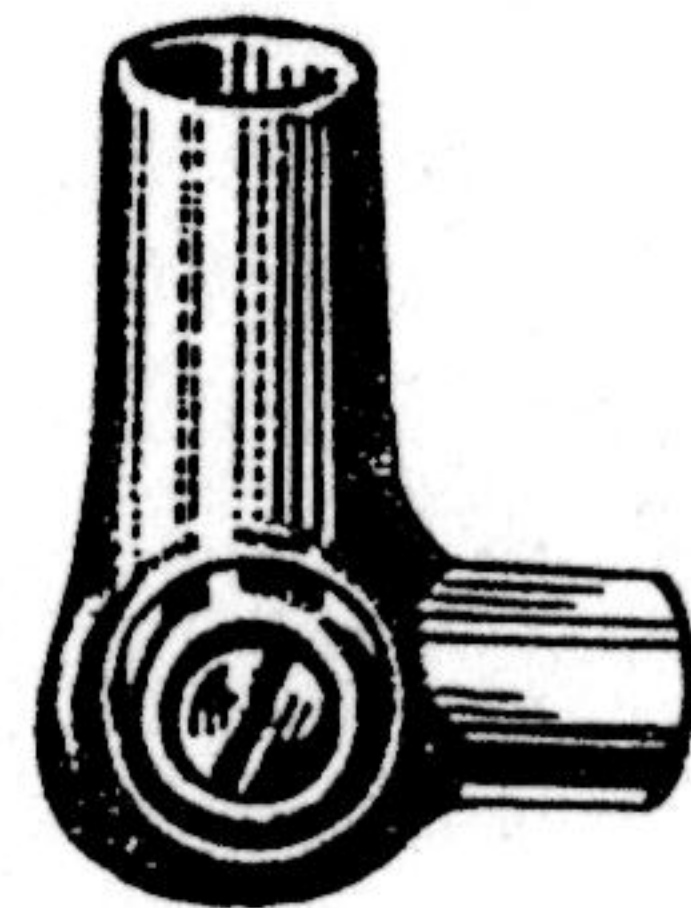

824

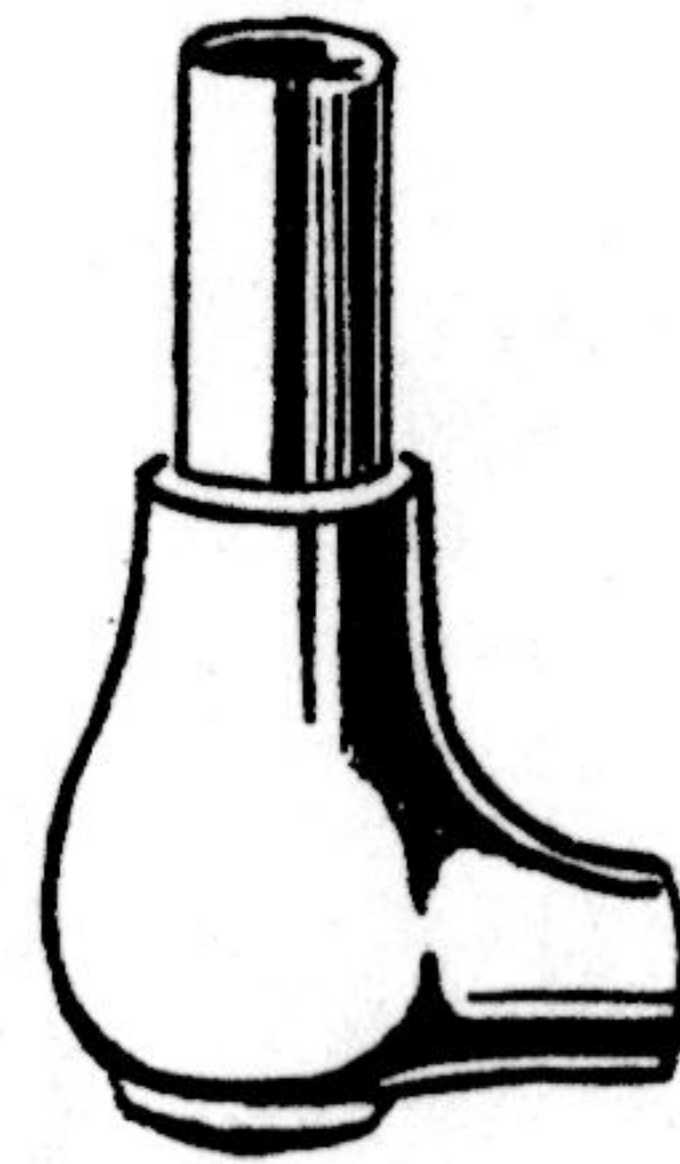

823

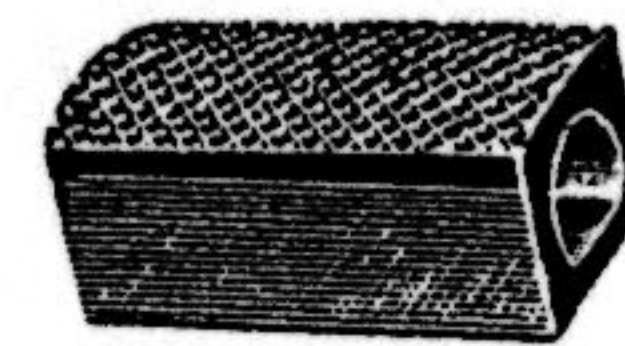

765



764

802 Casque métal, miroir, filtre
 cailloux 55/56
 802 A Casque métal, miroir, filtre
 cailloux 55/56

Exemples

910 Casque métal, miroir, filtre

Modèles

923 Goggles, métal, miroir, filtre
 mollardine 55/56

930 Casque métal, miroir, filtre
 cailloux 55/56

762 Casque métal, miroir, filtre
 cailloux 55/56

865 Casque métal, miroir, filtre
 cailloux 55/56

Exemples

760 Casque métal, miroir, filtre
 cailloux 55/56

824 Casque métal, miroir, filtre
 cailloux 55/56

823 Casque métal, miroir, filtre
 cailloux 55/56

765 Casque métal, miroir, filtre
 cailloux 55/56

764 Casque métal, miroir, filtre
 cailloux 55/56

De la part de FAN DE SCOOTER

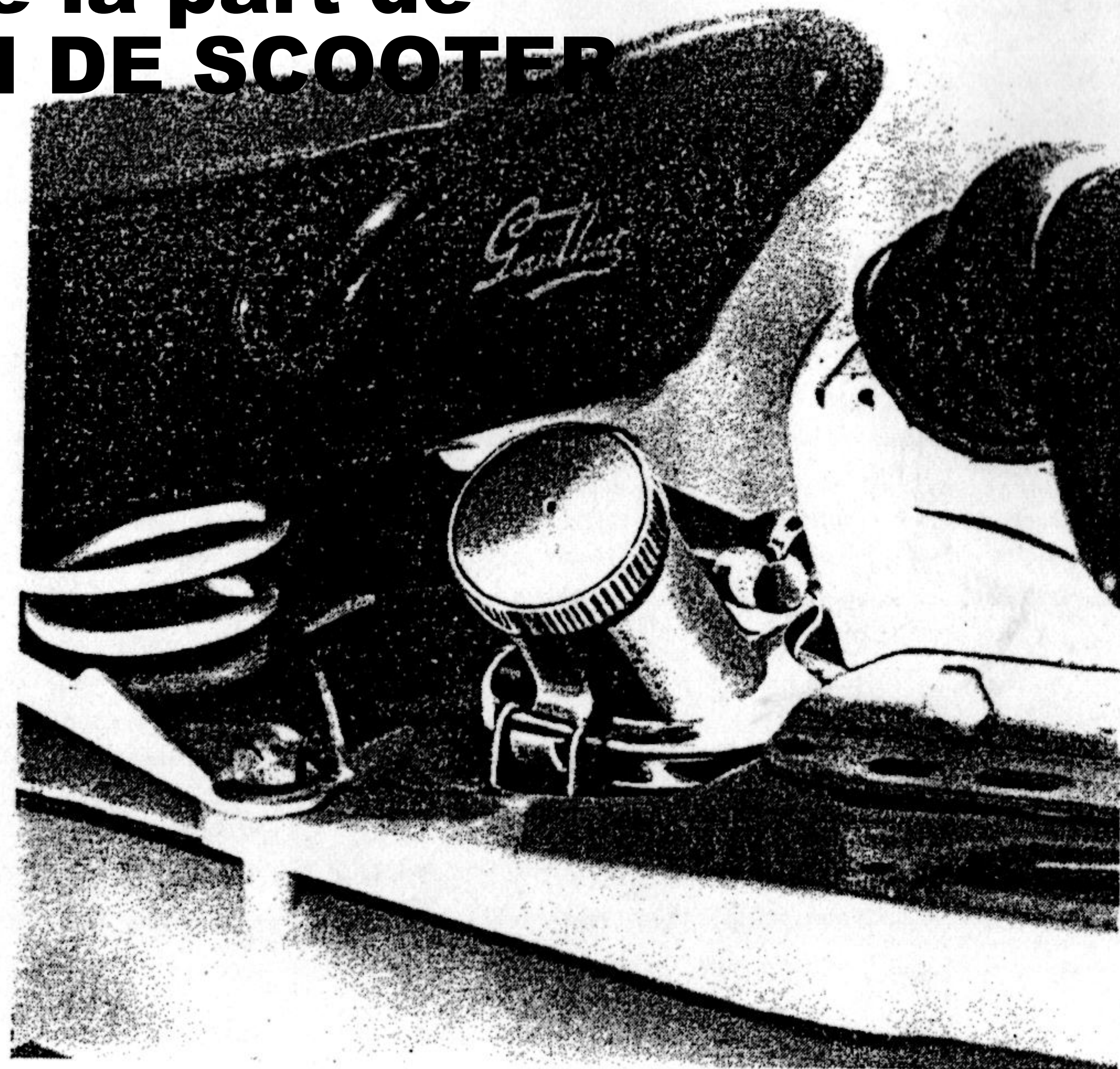

937 - Jauge fermée

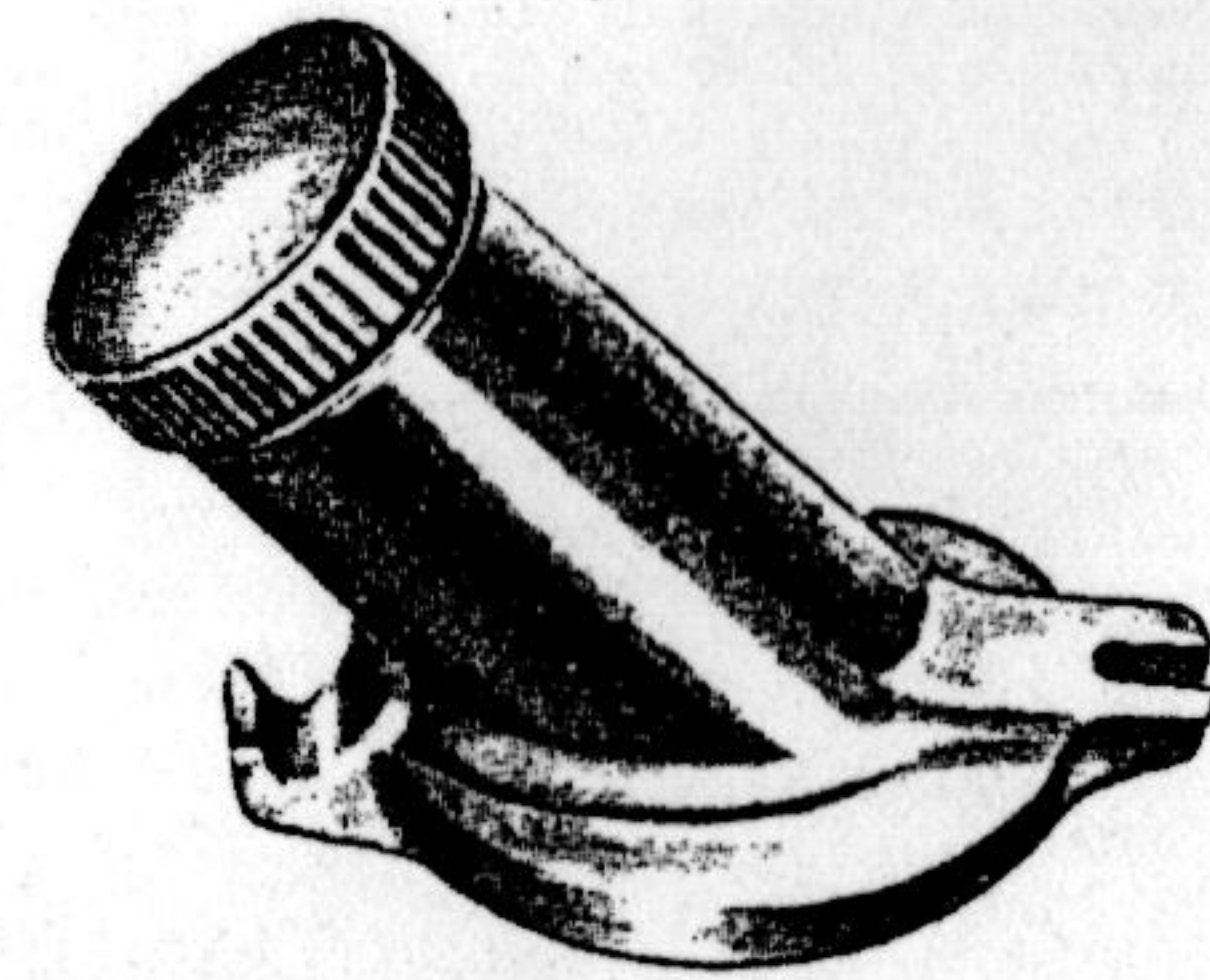
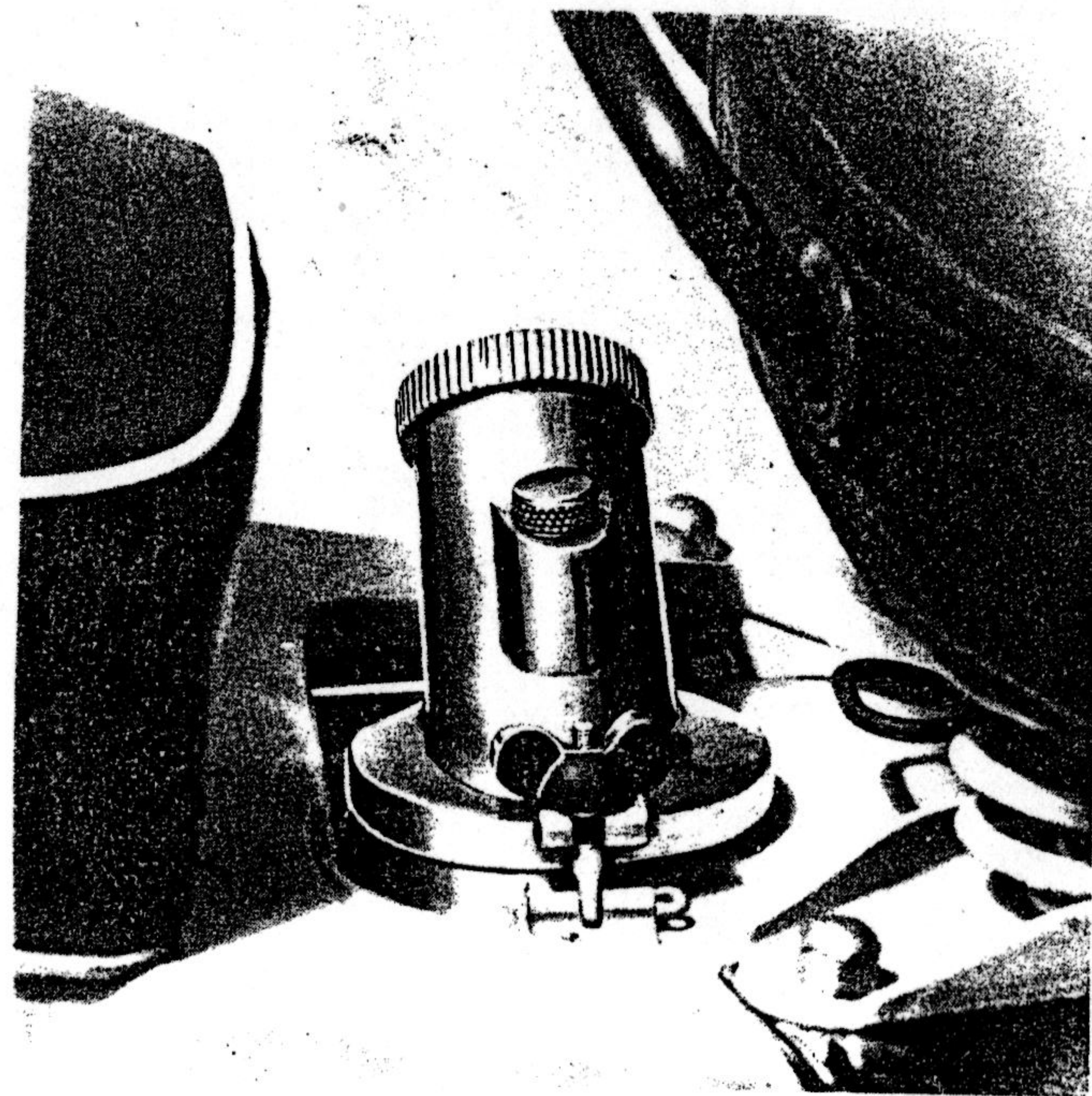

927

937 - Jauge ouverte

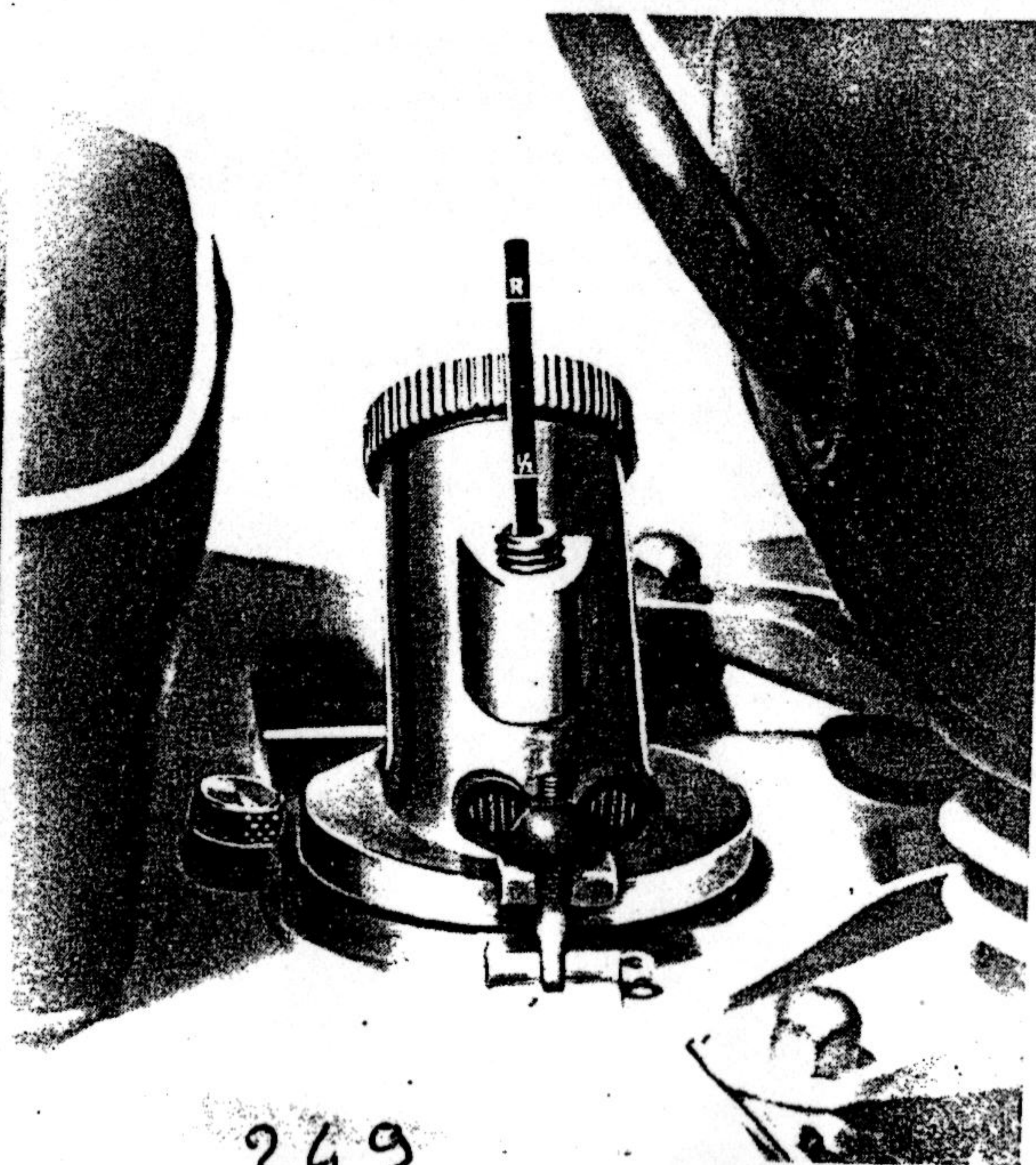

249

Bouchons de Réservoir

927 - Bouchon Tube Verseur, sans jauge

937 - Bouchon Tube Verseur, avec jauge flottante escamotable

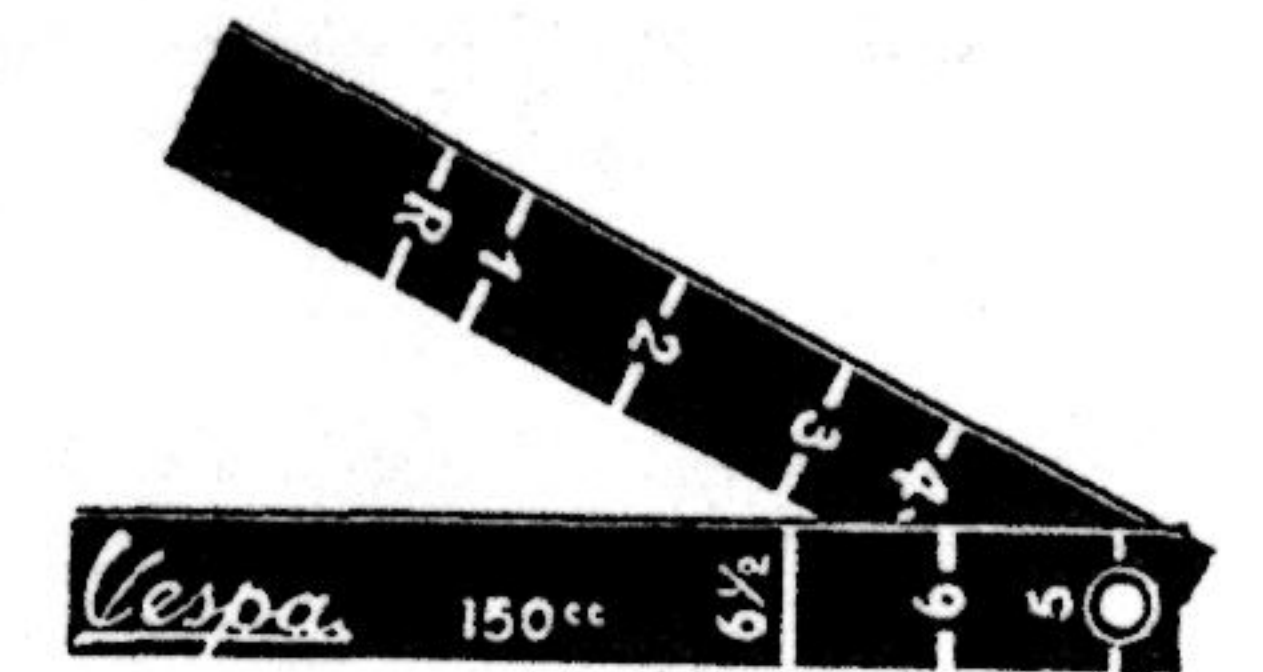

925

Jauges

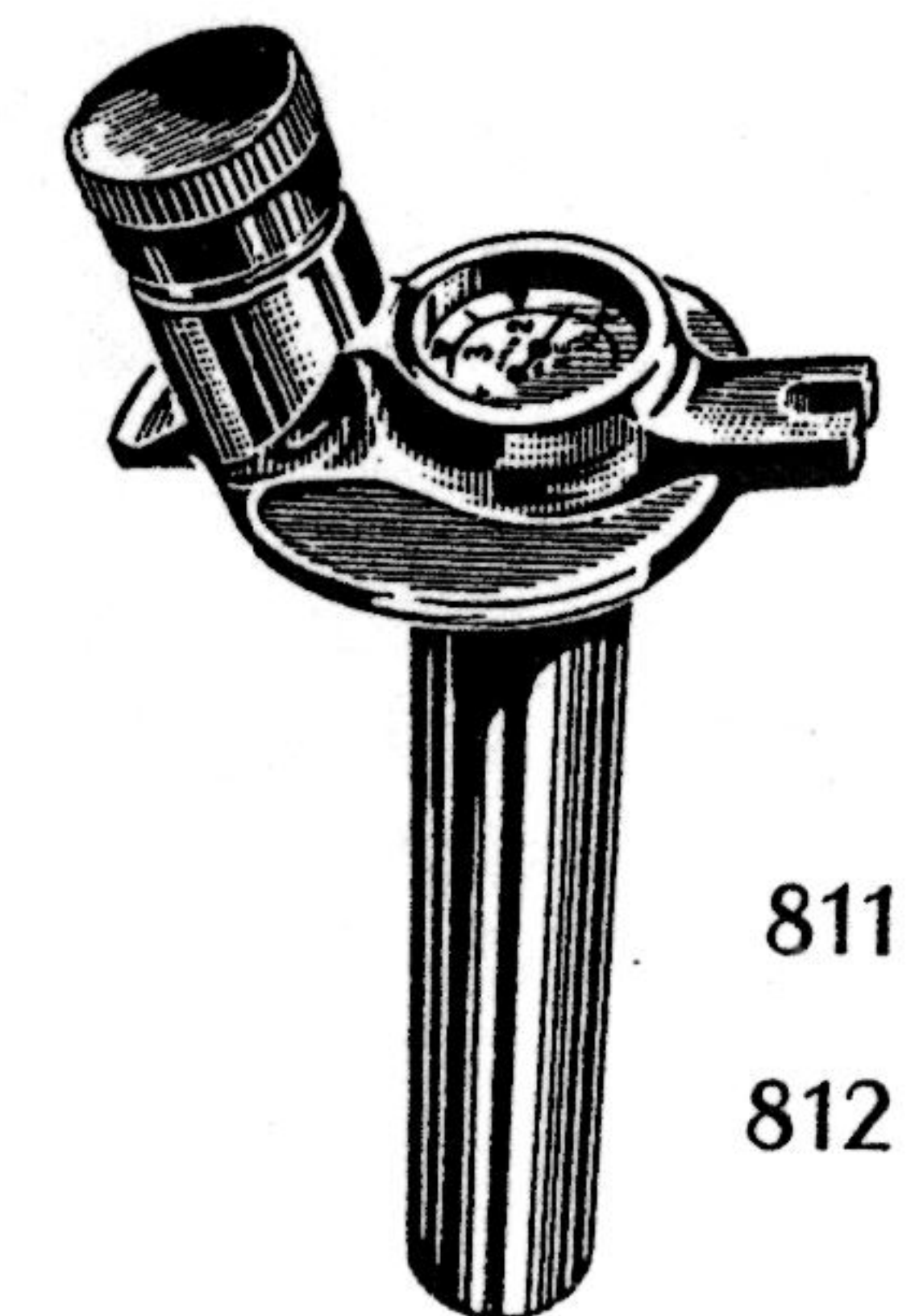

811

812

925 - Jauge Règlette

811 - Jauge Extra Luxe à Cadran

812 - Jauge Luxe à Cadran

De la part de FAN DE SCOOTER

928 - Jerrycan 5 litres, couleur 56,
Aubry

928

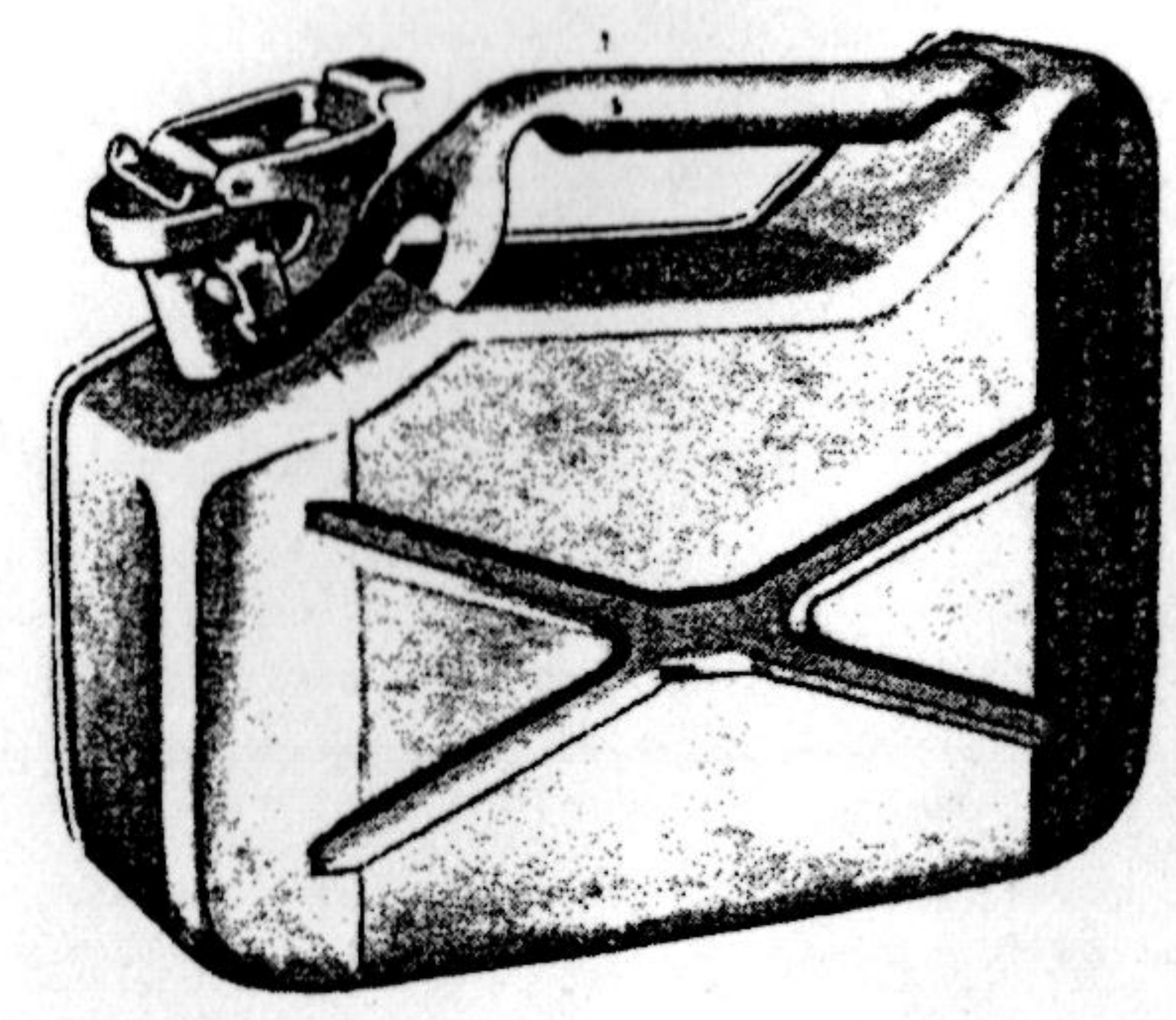

926 - Bec verseur pour Jerrycan

926

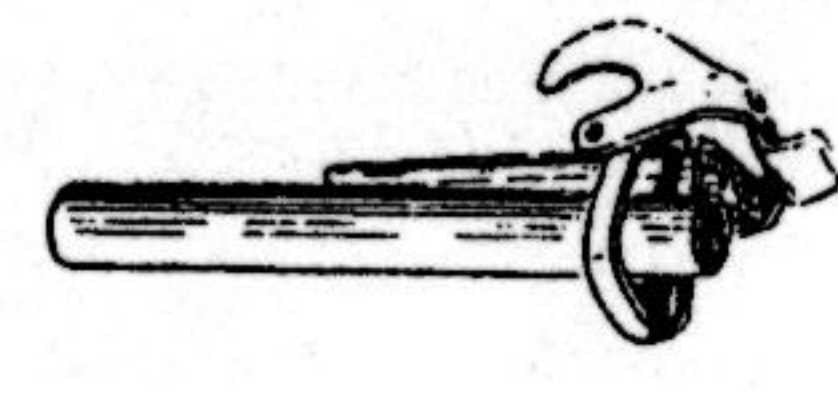

*

864 - Porte-Bidon Mérat, type Universel

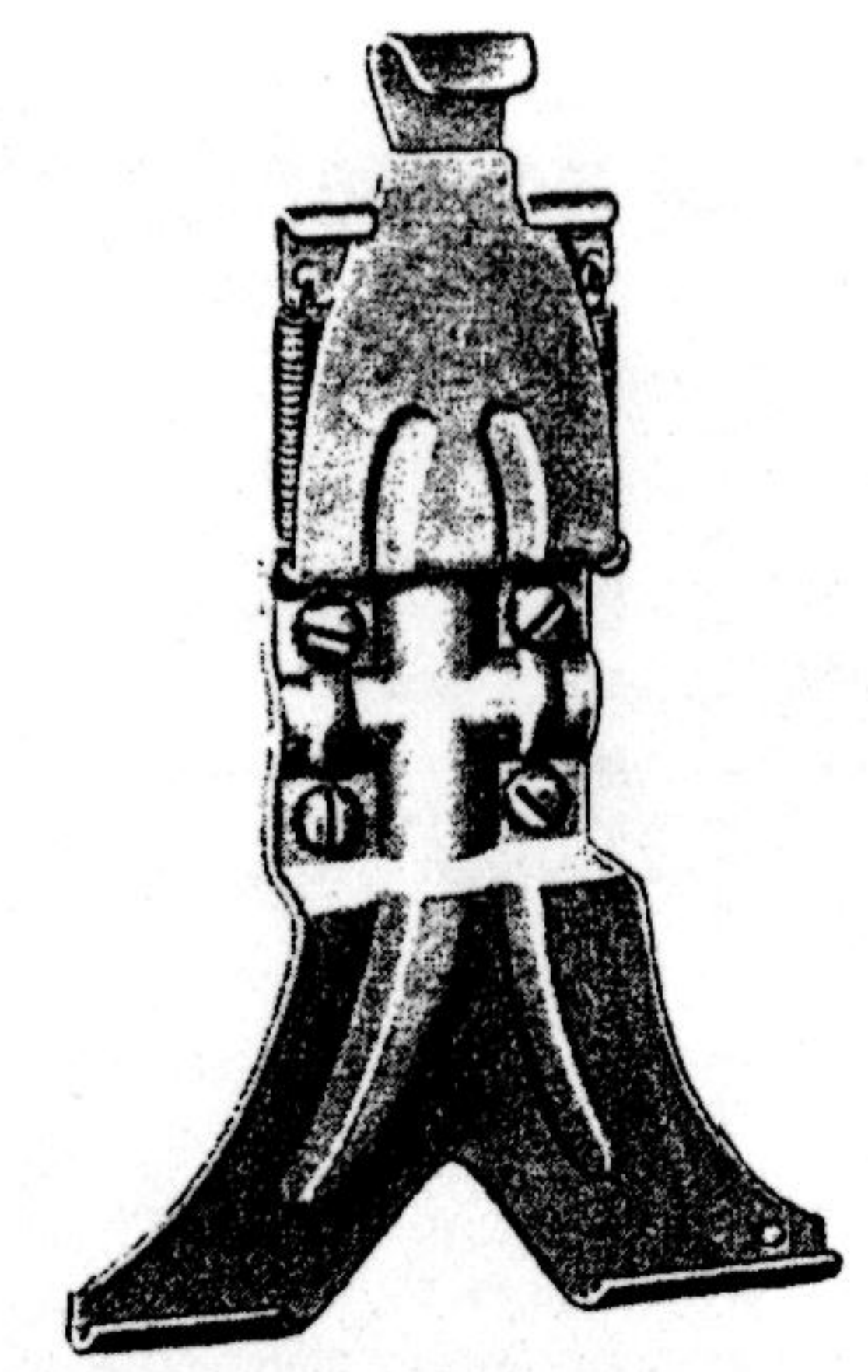

864

892 - Tuyau d'échappement double
chromé, modèle 52, 53

892

893 - Tuyau d'échappement double
chromé, modèle 54, 56

893

885 - Tuyau d'échappement
Type "Reactor 55"

885

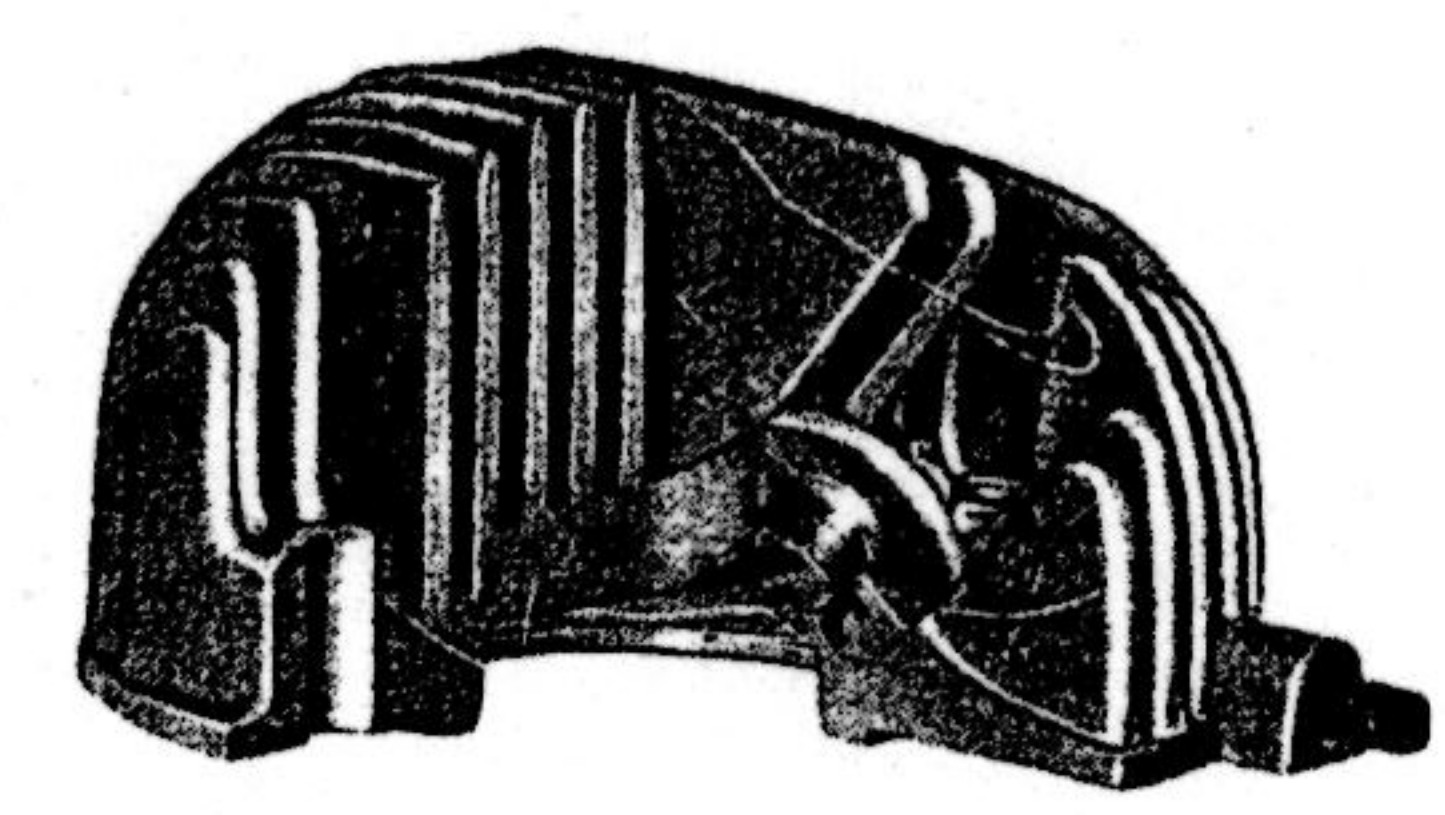
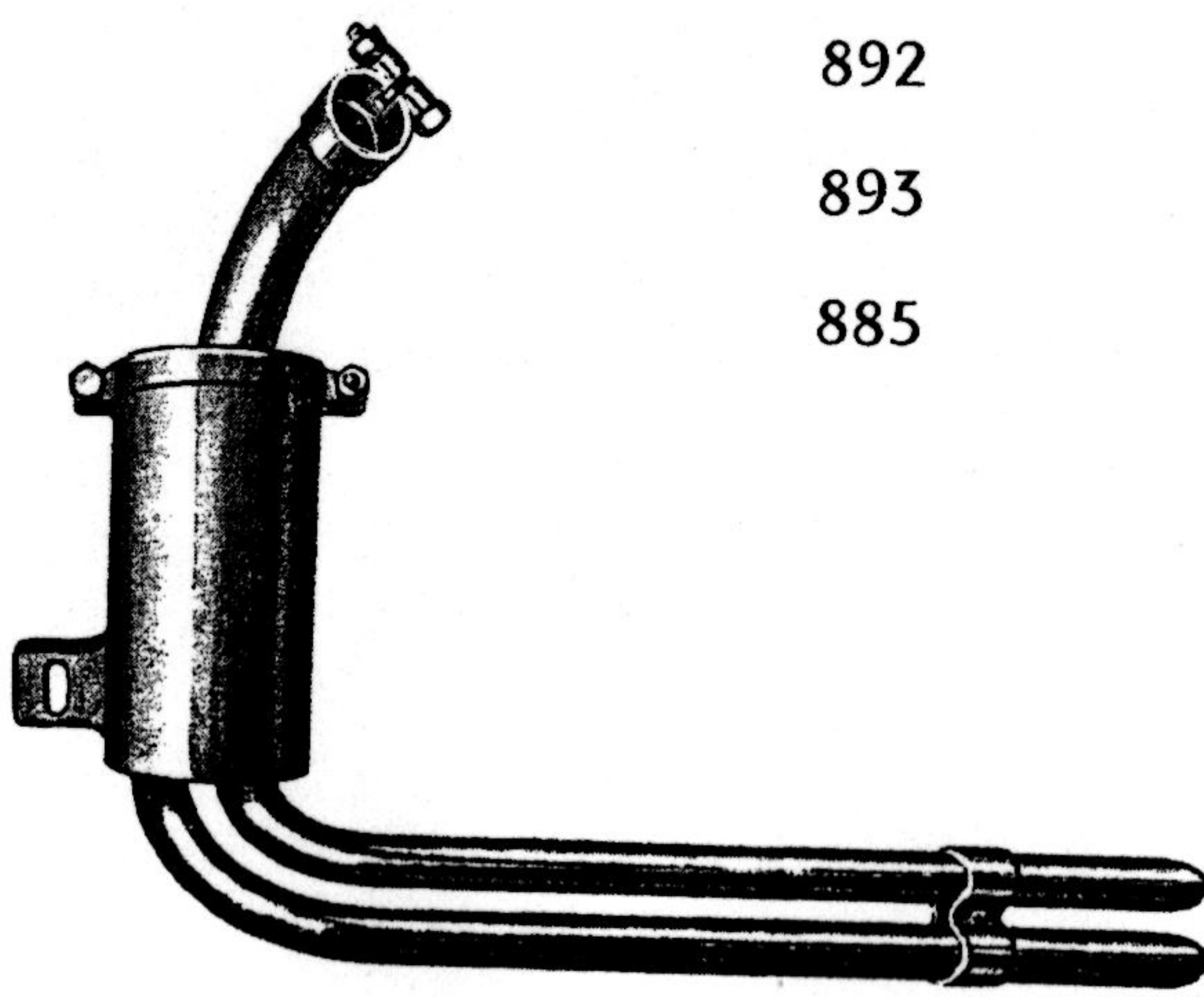

861

*

861 - Super Culasse VORTEX

*

814 - Enjoliveur de silencieux

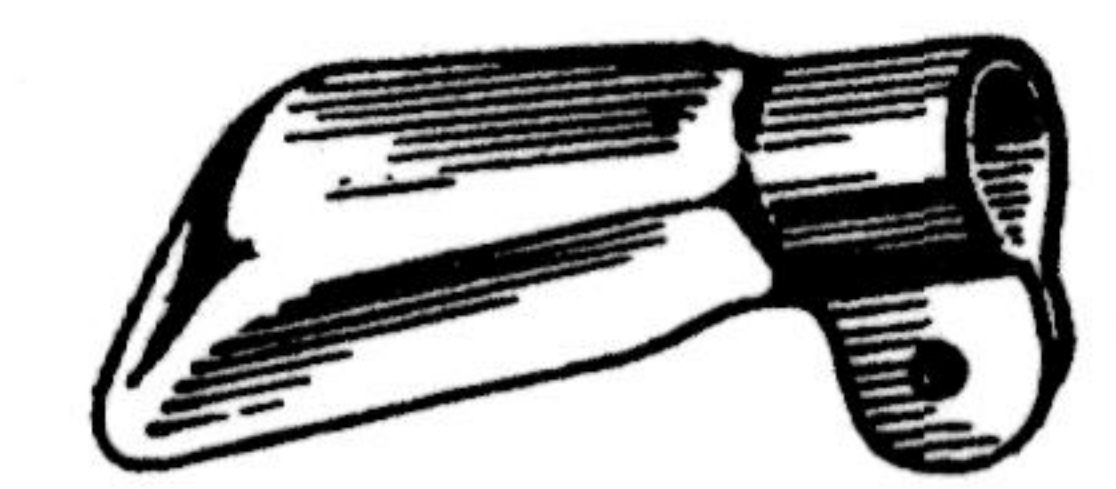

814

250

De la part de FAN DE SCOOTER

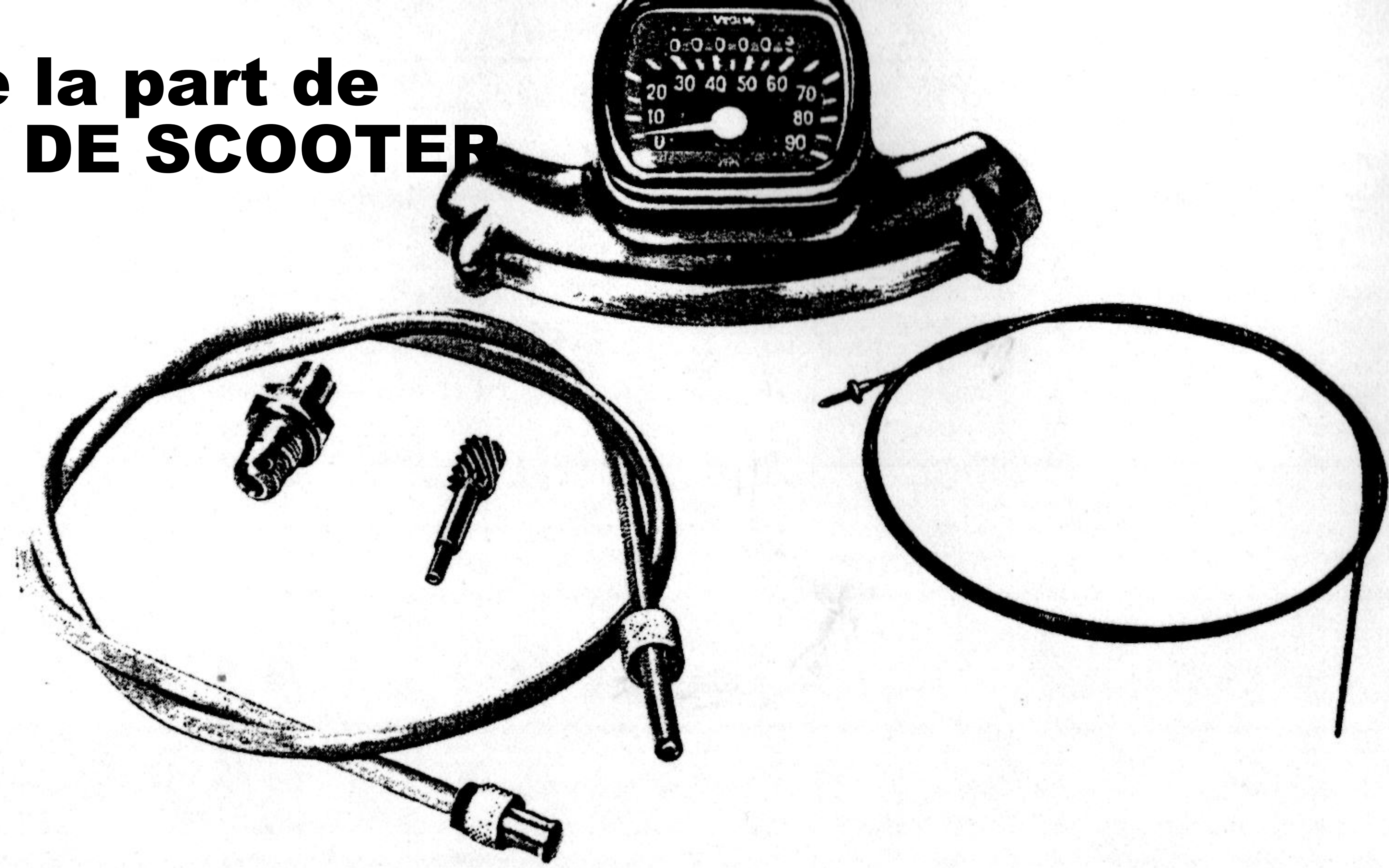

- 1039 - Compteur complet avec Bloc adaptable pour Scooter 52
- 1041 - Compteur Veglia complet, modèles 53, 56
- 1042 - Bloc de Compteur nu
- 758 - Câble de Compteur Veglia ED
- 759 - Transmission de Compteur Veglia

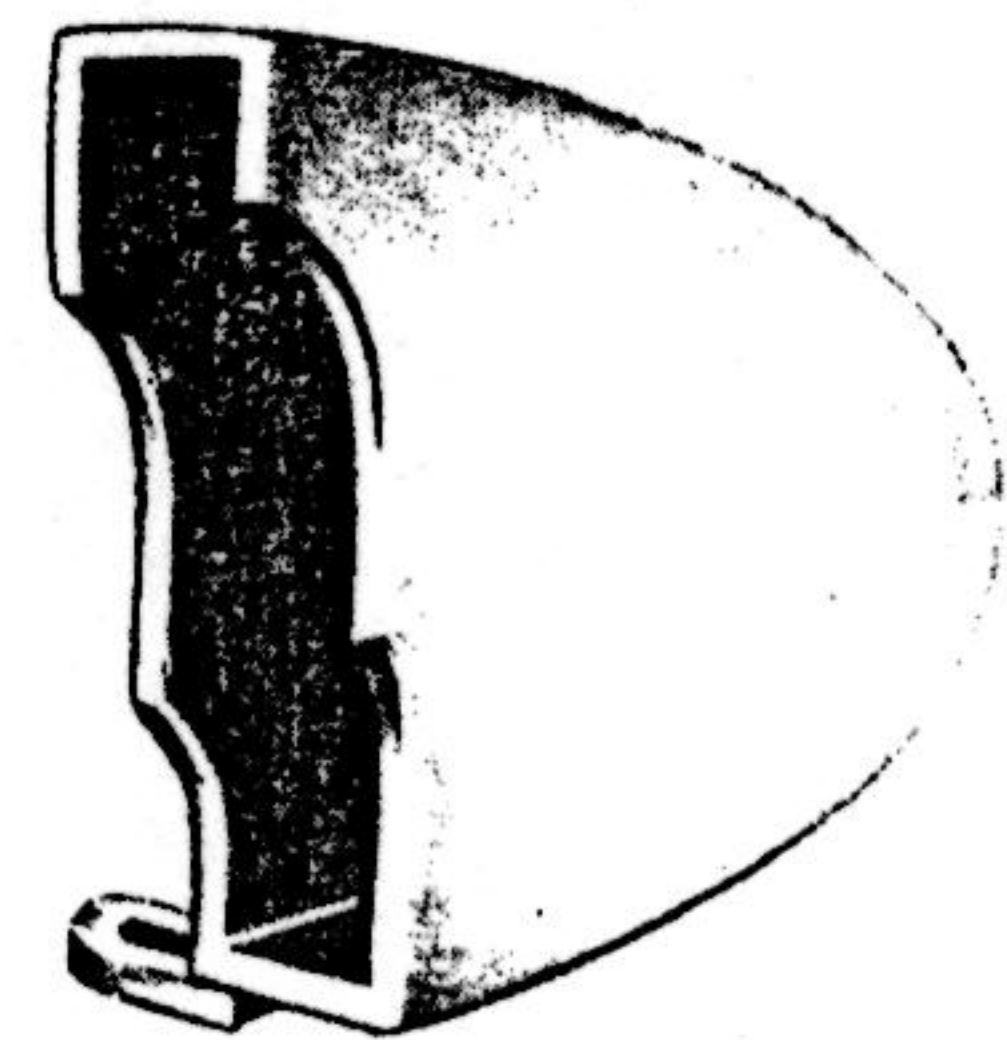

803 -

Cache-Selecteur

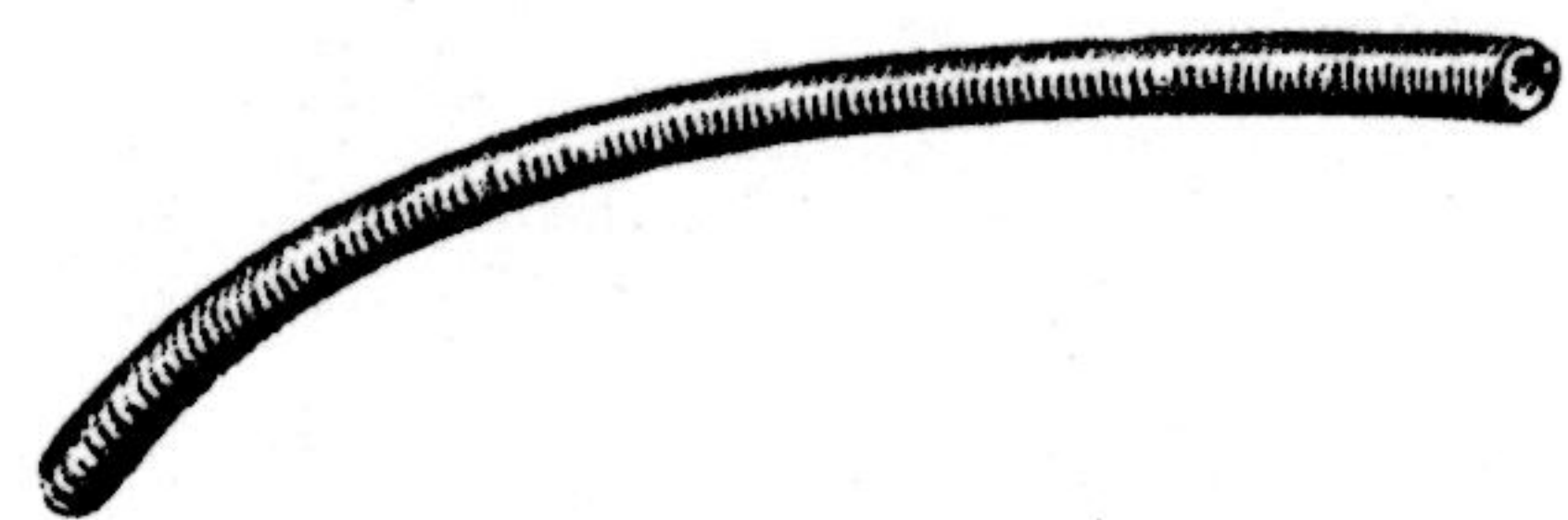

- 772 - Gaine de Transmission en couronne de 20 mètres

Compteurs et Accessoires

Câbles et Gaines

Câble

- 752 - Câble d'embrayage ancien et nouveau modèle
- 753 - Câble de changement de vitesses
- 754 - Câble de Frein Avant
- 755 - Câble de Frein Arrière
- 756 - Câble de Gaz
- 757 - Câble d'Embrayage Tri
- 753A - Câble de changement de vitesses Tri
- 754A - Câble de Frein Avant Tri
- 756A - Câble de Gaz Tri

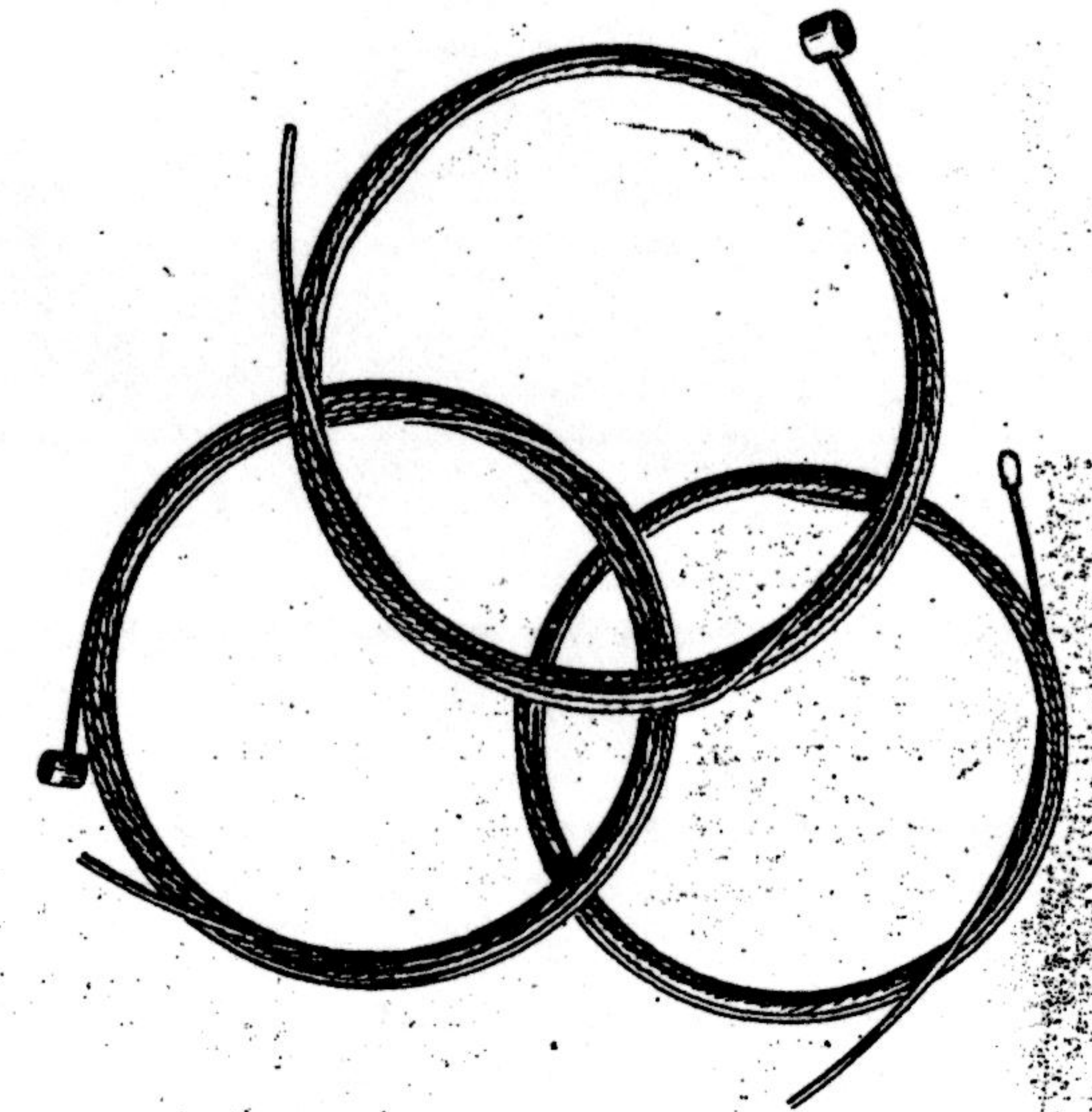

Transmission

- 742 - Transmission d'Embrayage
- 743 - Transmission de changement de vitesses
- 744 - Transmission de Frein AV
- 745 - Transmission de Frein AR
- 746 - Transmission de Gaz
- 742A - Transmission d'embrayage Tri
- 743A - Transmission de vitesses Tri
- 744A - Transmission de Frein AV Tri
- 746A - Transmission de gaz Tri

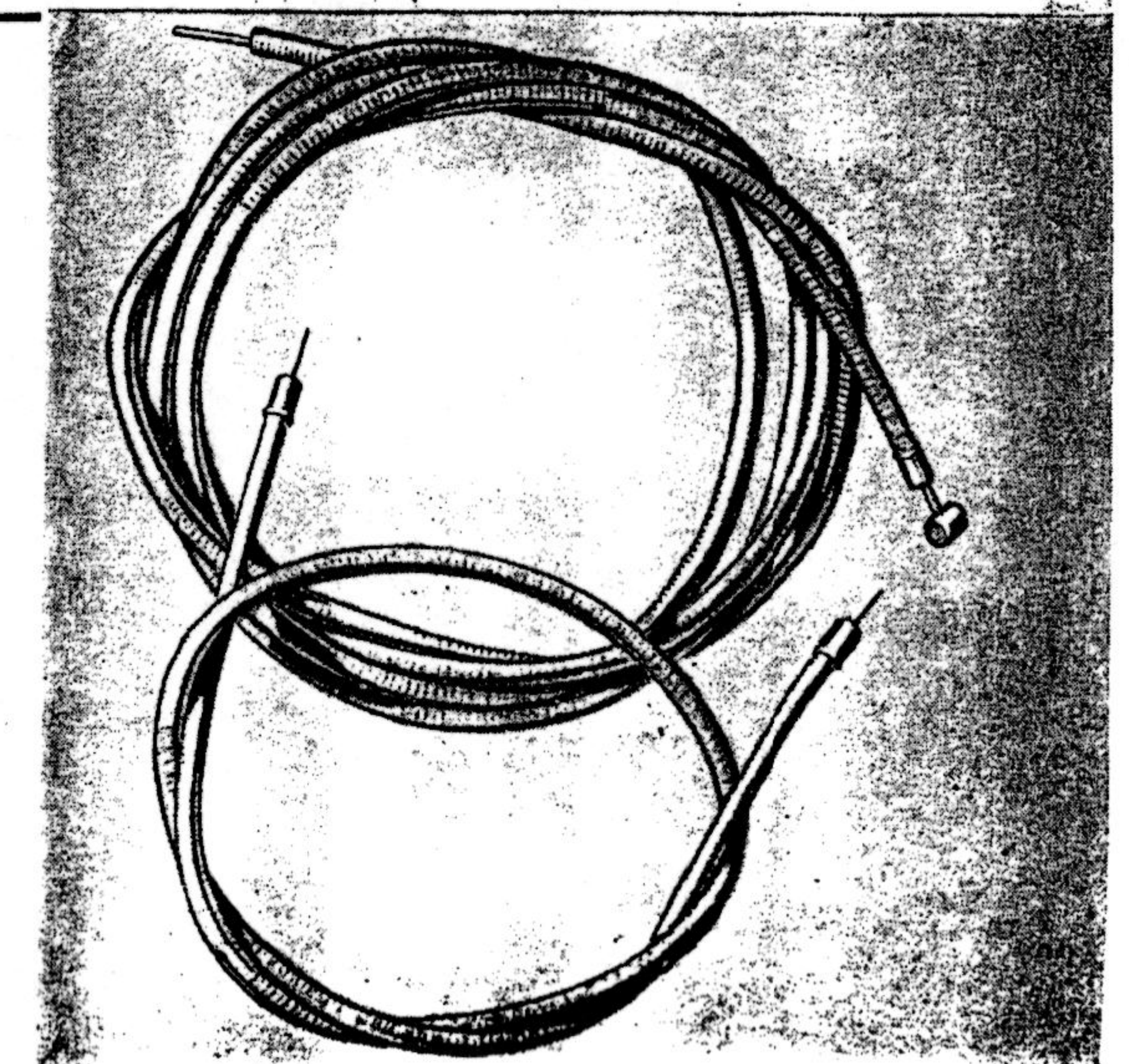

De la part de FAN DE SCOOTER

VUE DE FACE

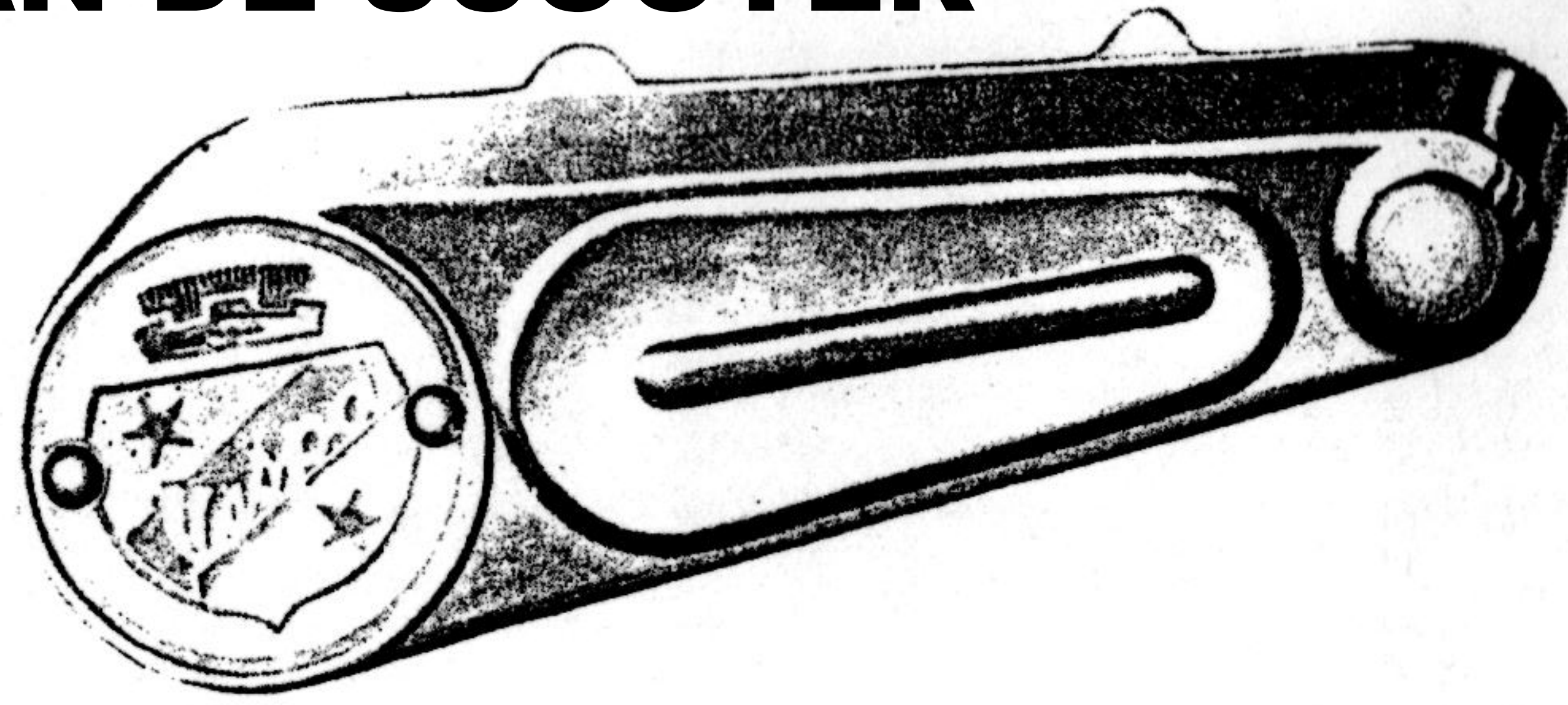

827 - Enjoliveur de Bras d'Amortisseur, laiton chromé.

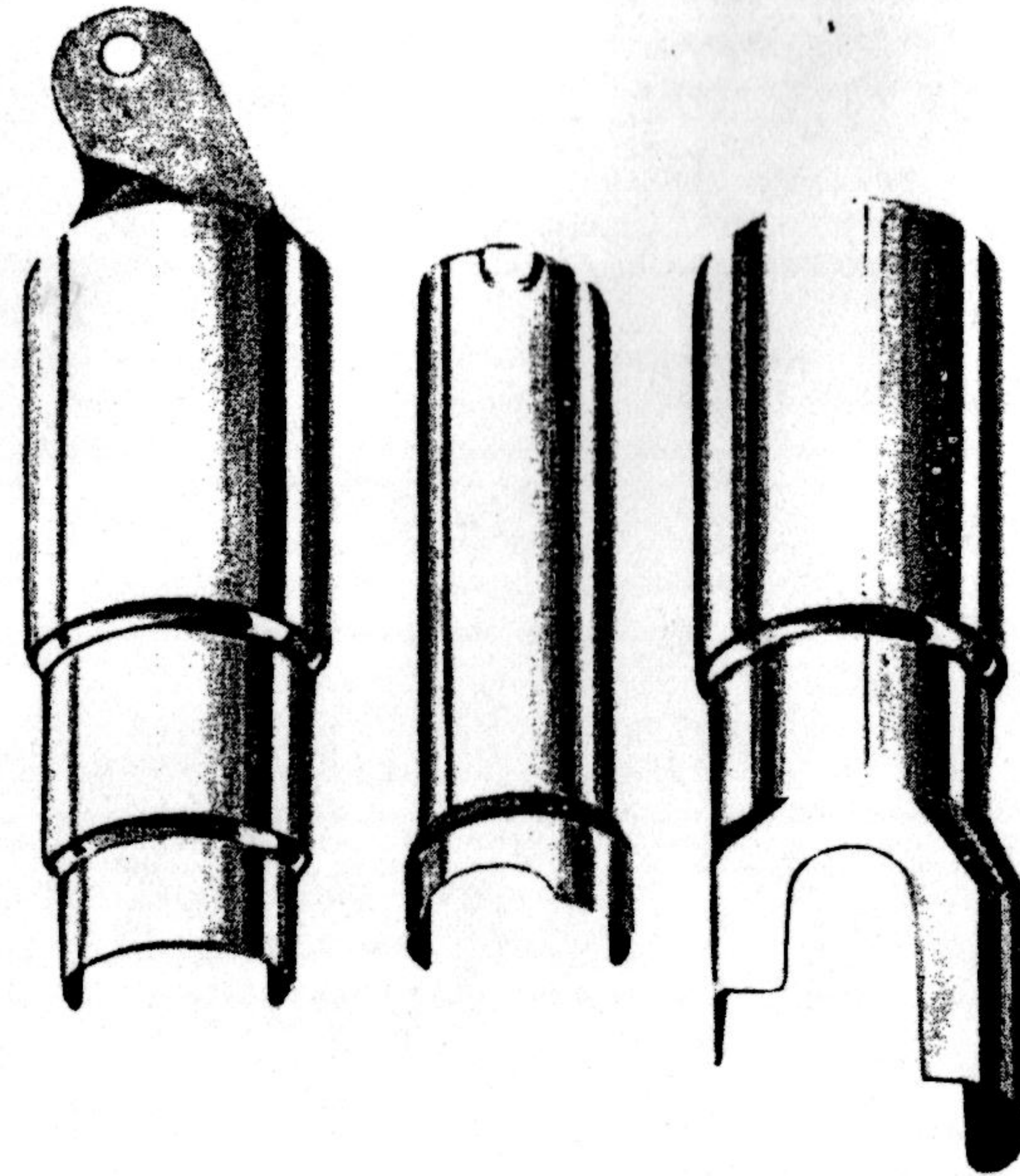

977 - Enjoliveur de Suspension AV 4 pièces entièrement chromé, pièce coulissante, laiton chromé.

Fixation sans perçage par collier de serrage.

VUE DE DOS

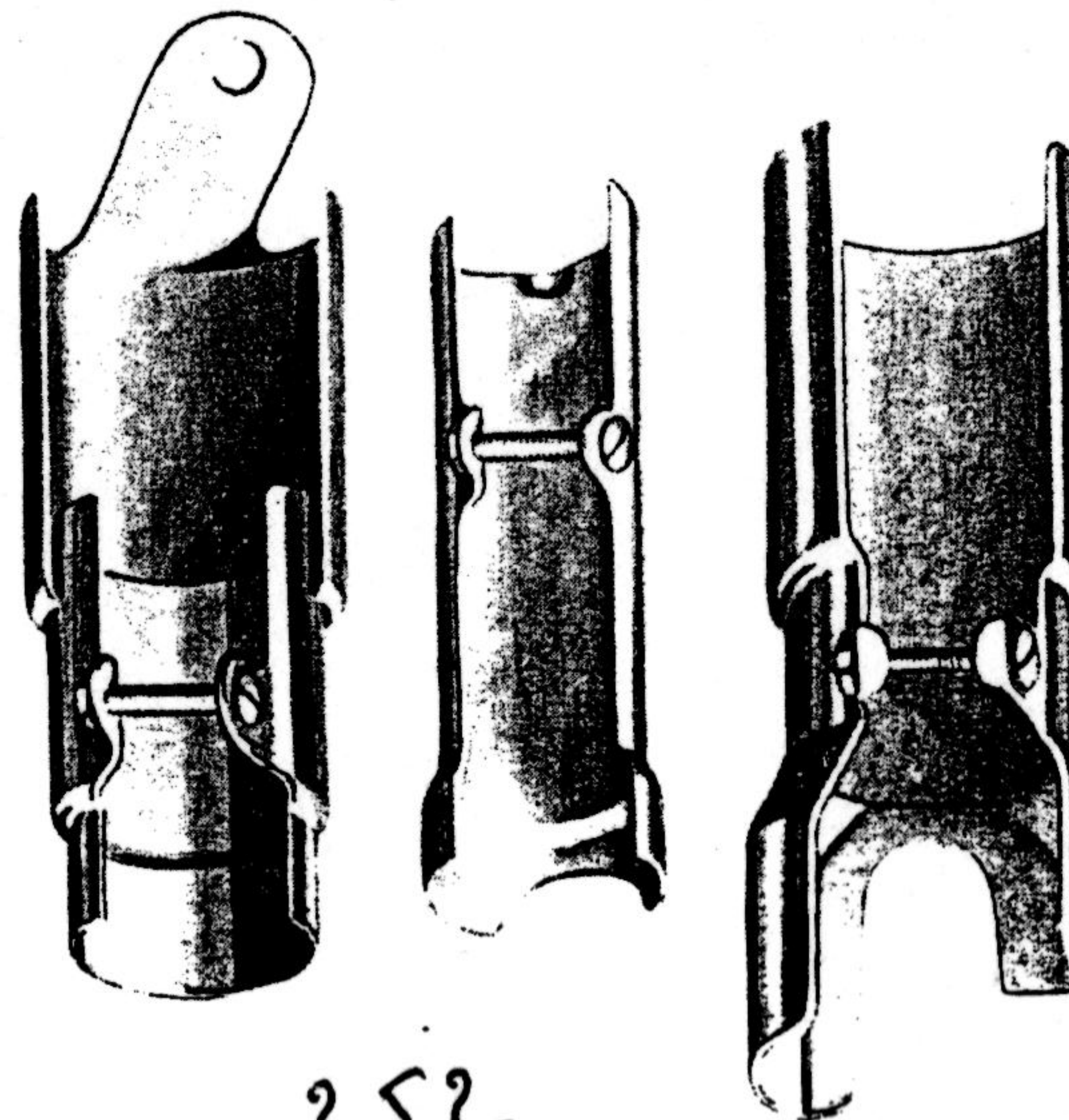

252



815 C - Enjoliveur à Rayons croisés. Laiton chromé.

990 - Enjoliveur à Rayons, laiton chromé, avec Sous-Enjoliveur à Rayons Rouge.

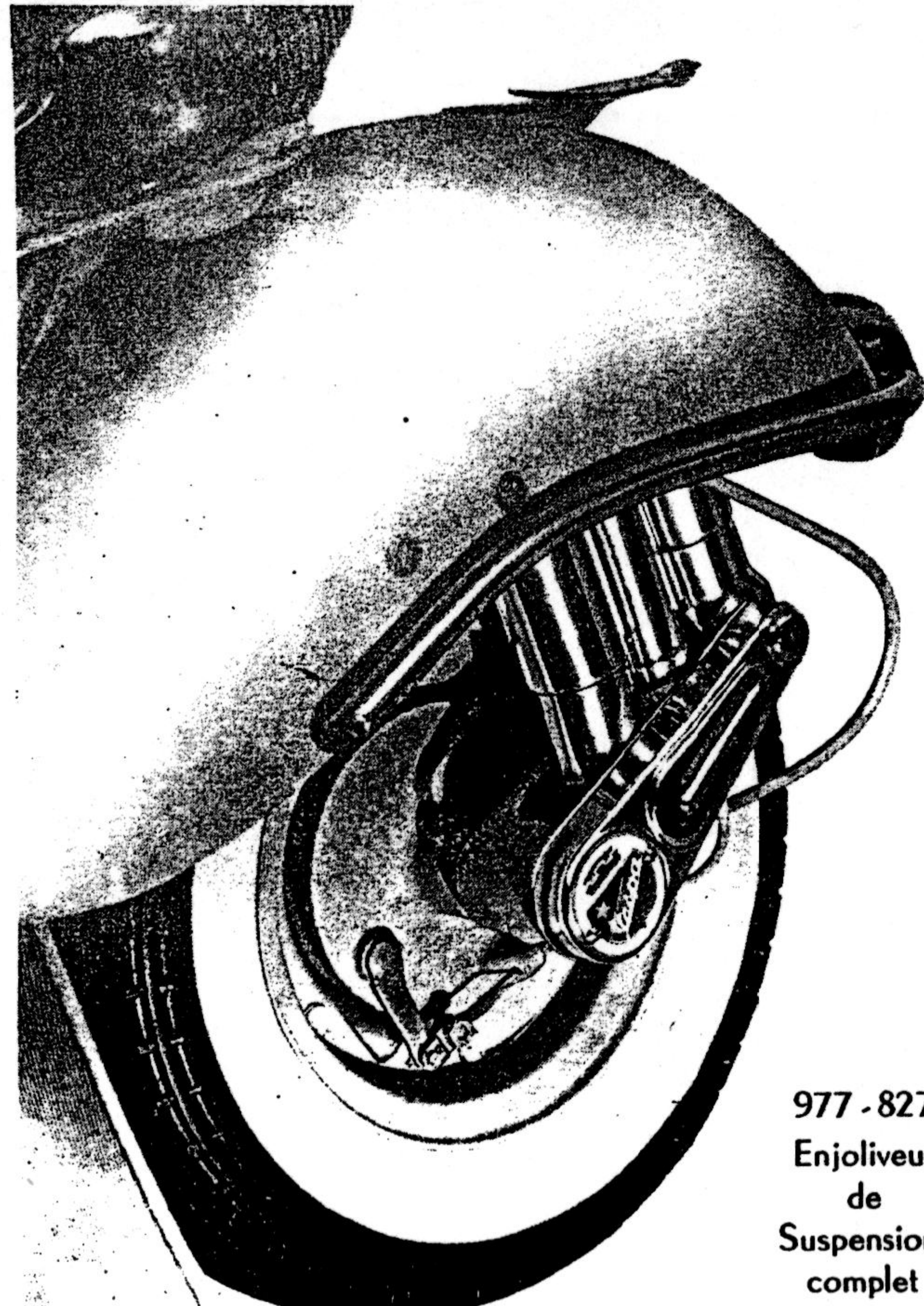

977 - 827
Enjoliveur
de
Suspension
complet

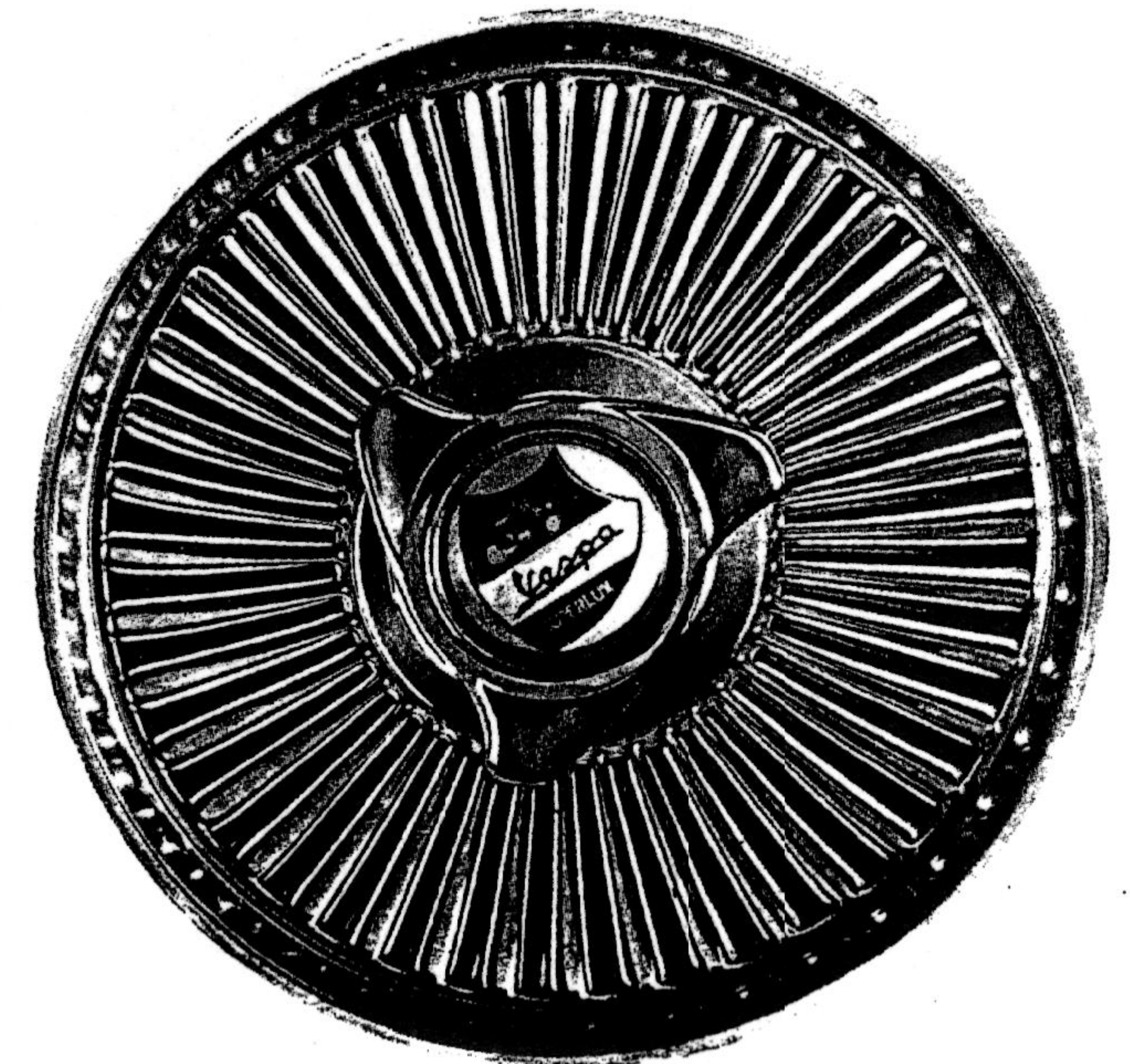

De la part de AN DE SCOOTER



1061

1062 - Parure 3 pièces comprenant :

1059 - Couvre-Selle Avant deux tons, tissu grain fourrure, fond matelassé.

1060 - Couvre-Selle Arrière deux tons, tissu grain fourrure, fond matelassé.

1061 - Couvre-Roue de Secours deux tons, tissu grain fourrure.

Se vend également séparément.

Se fait également uni.

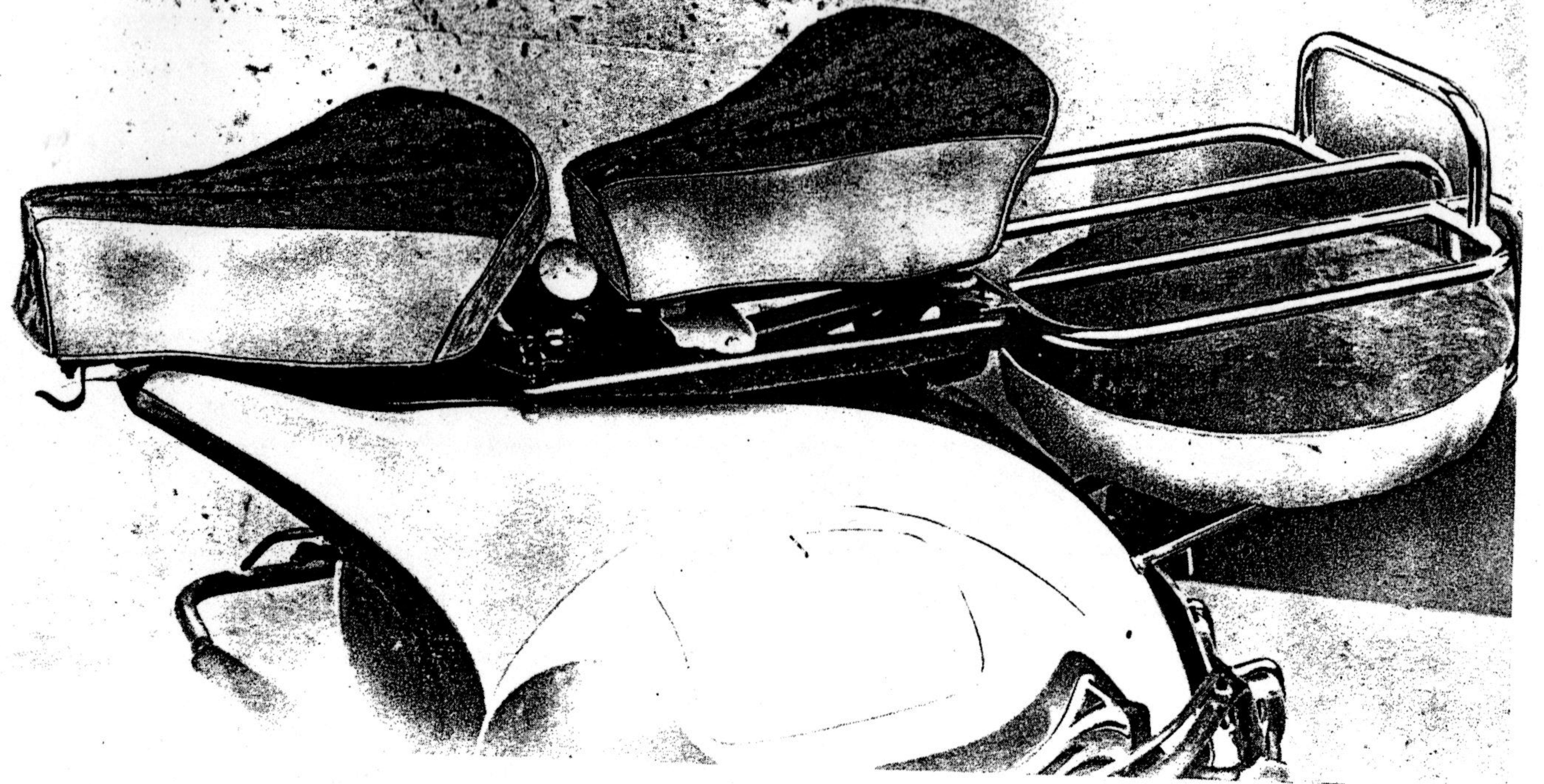

1062



1060



1059

De la part de
FAN DE SCOOTER



989

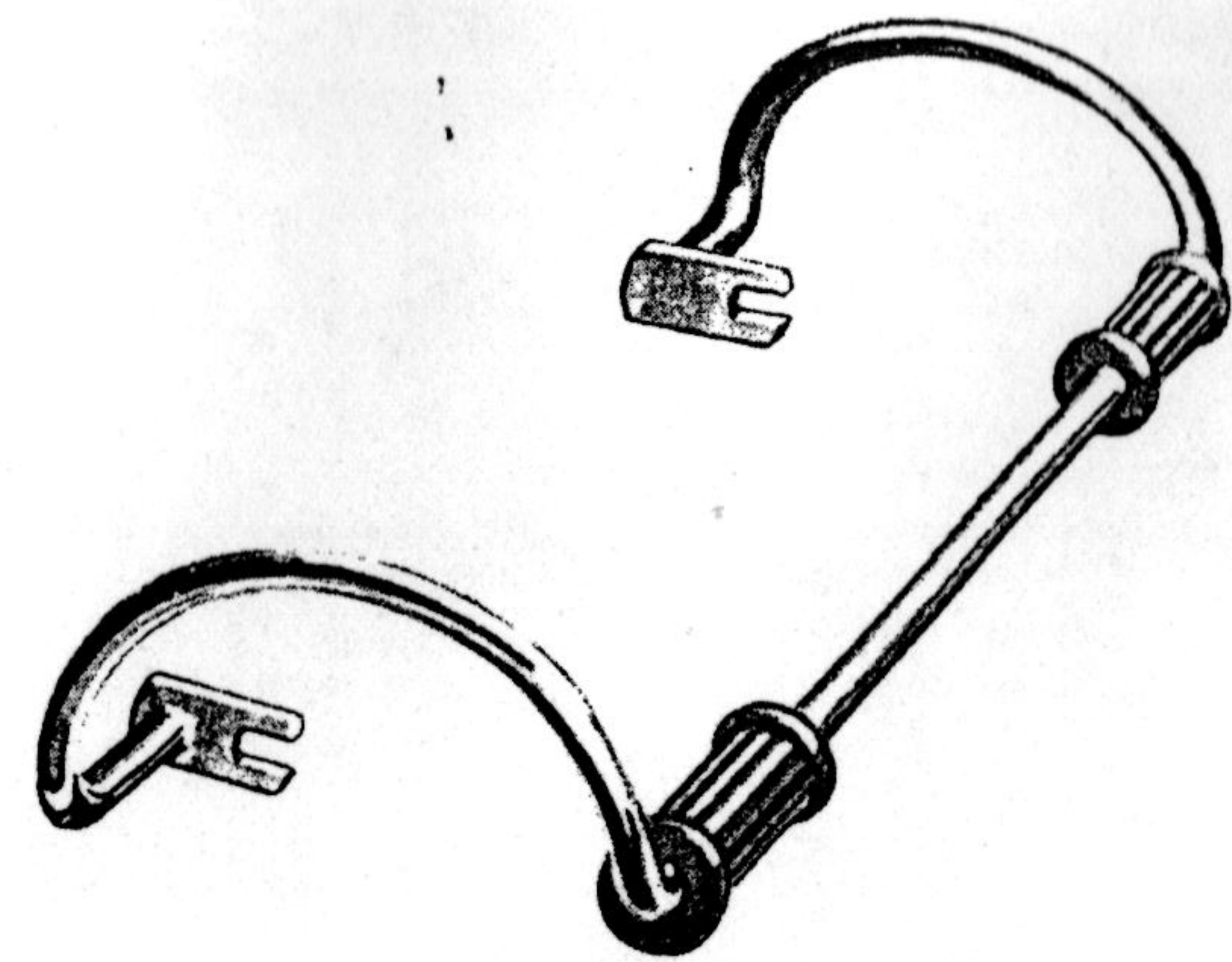

1072

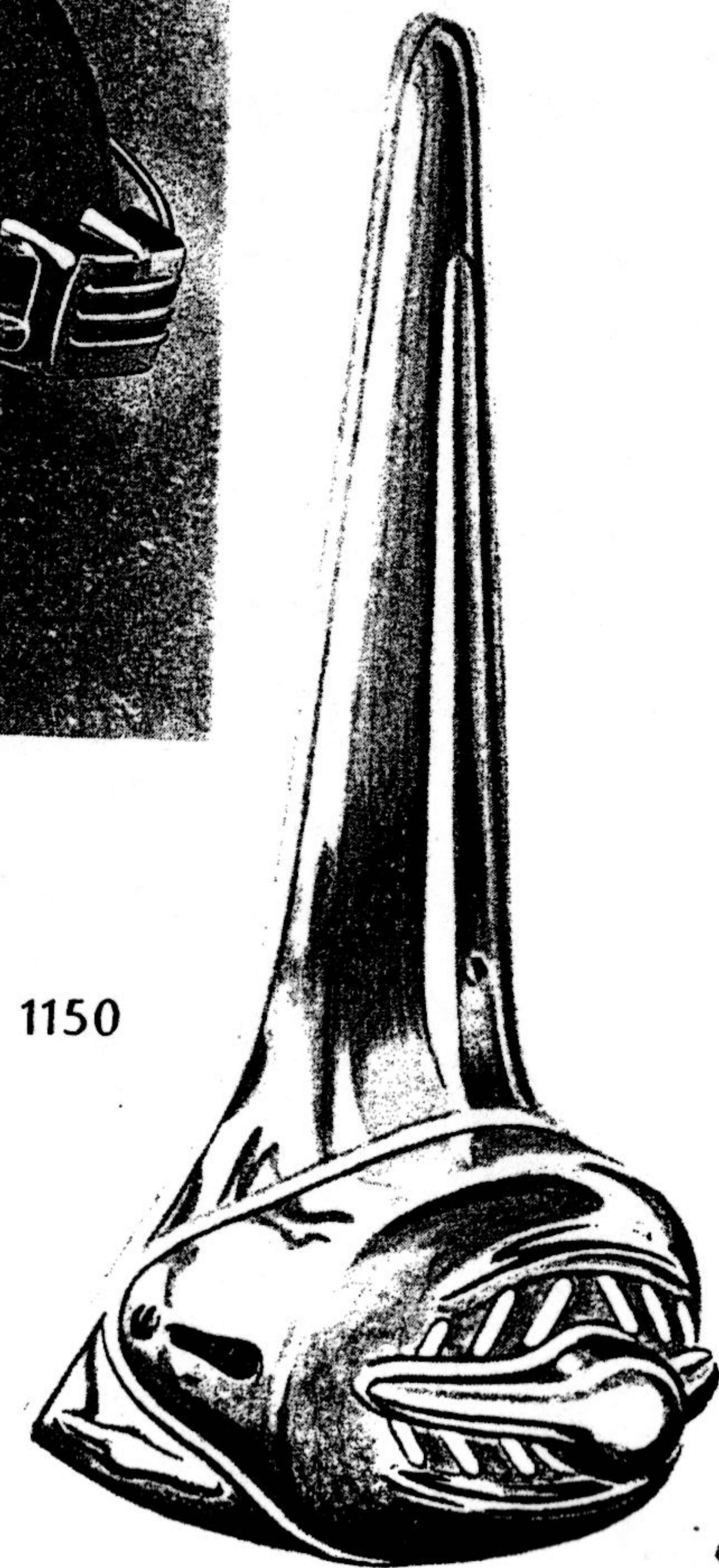
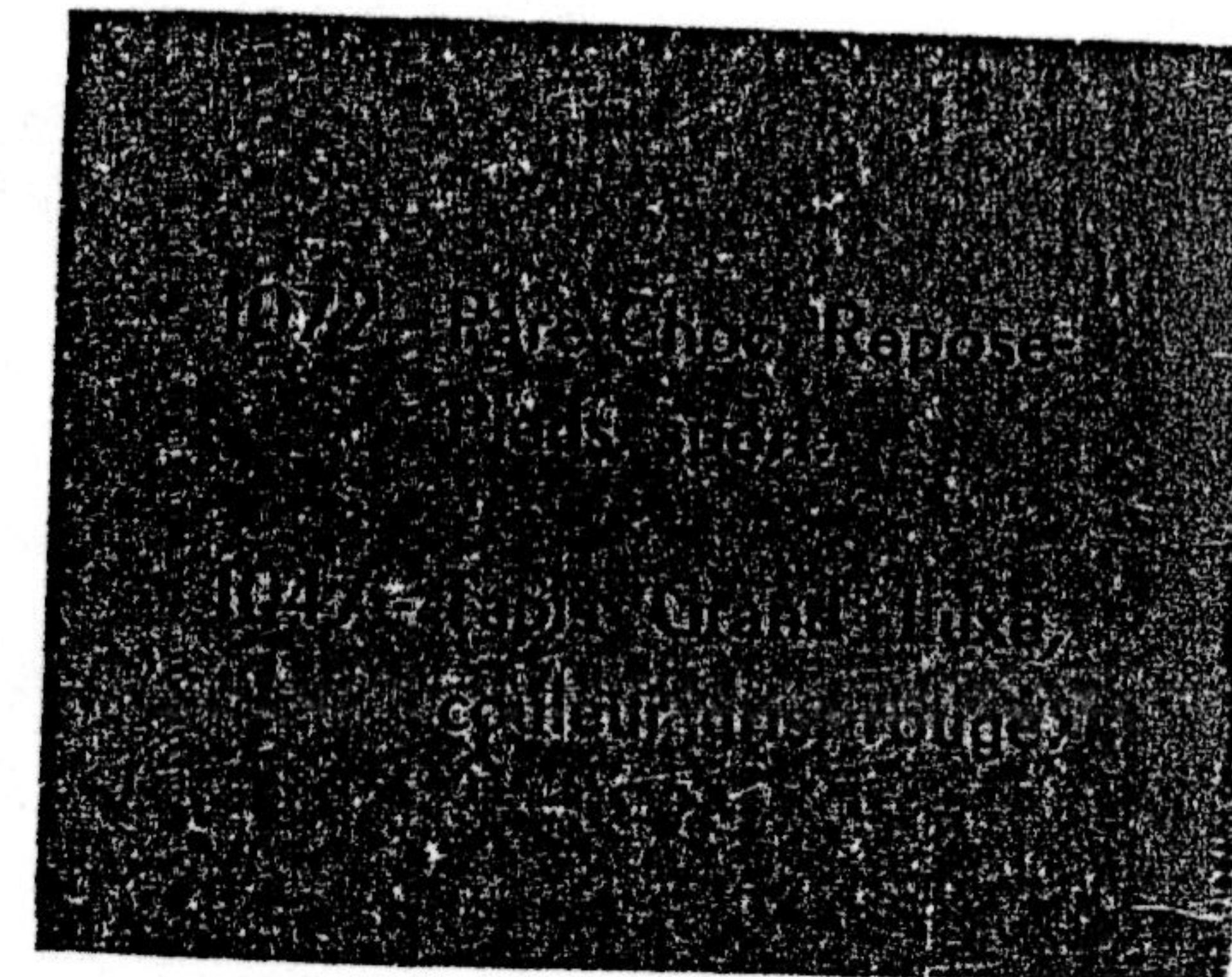

1150

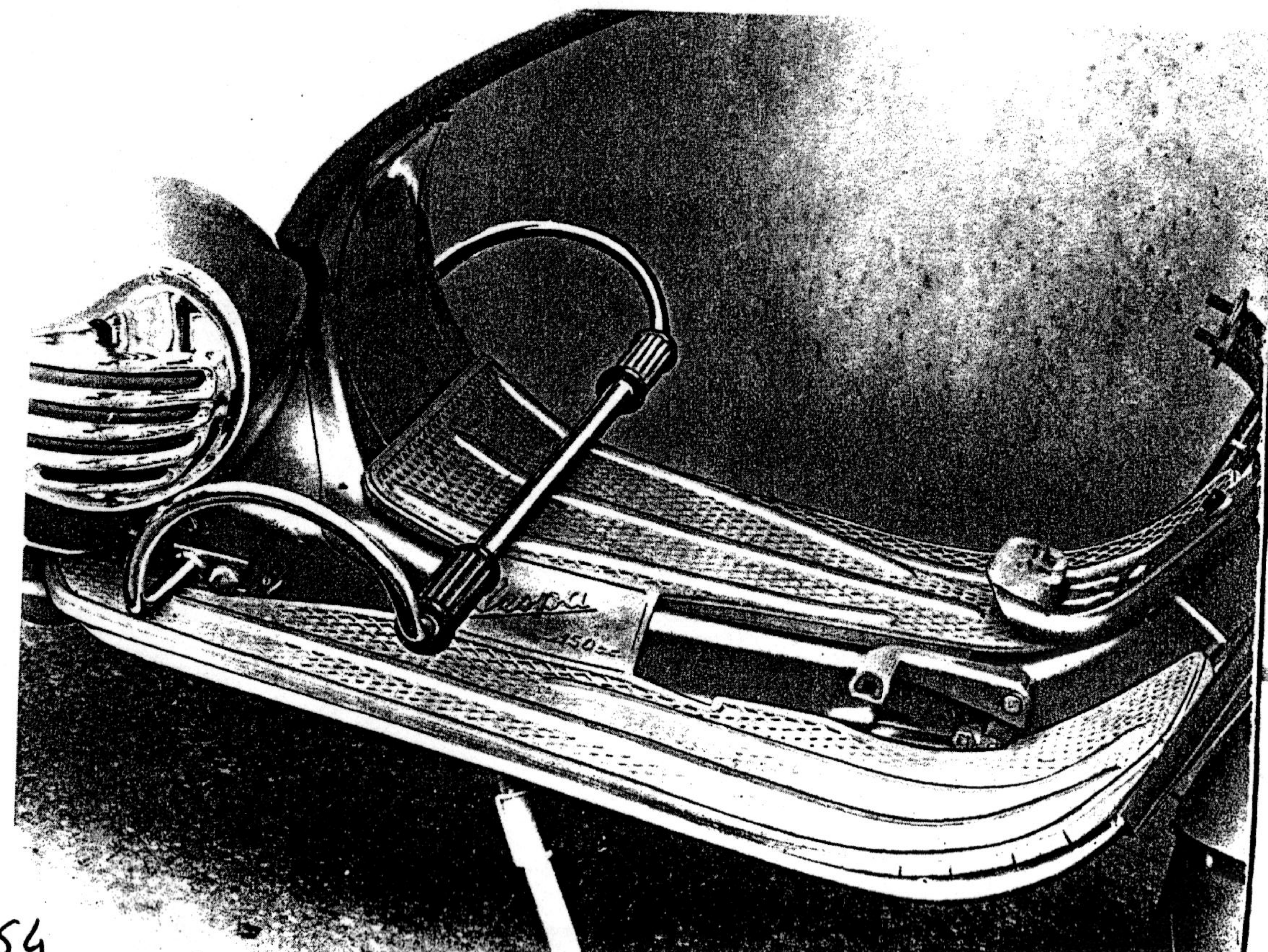

254

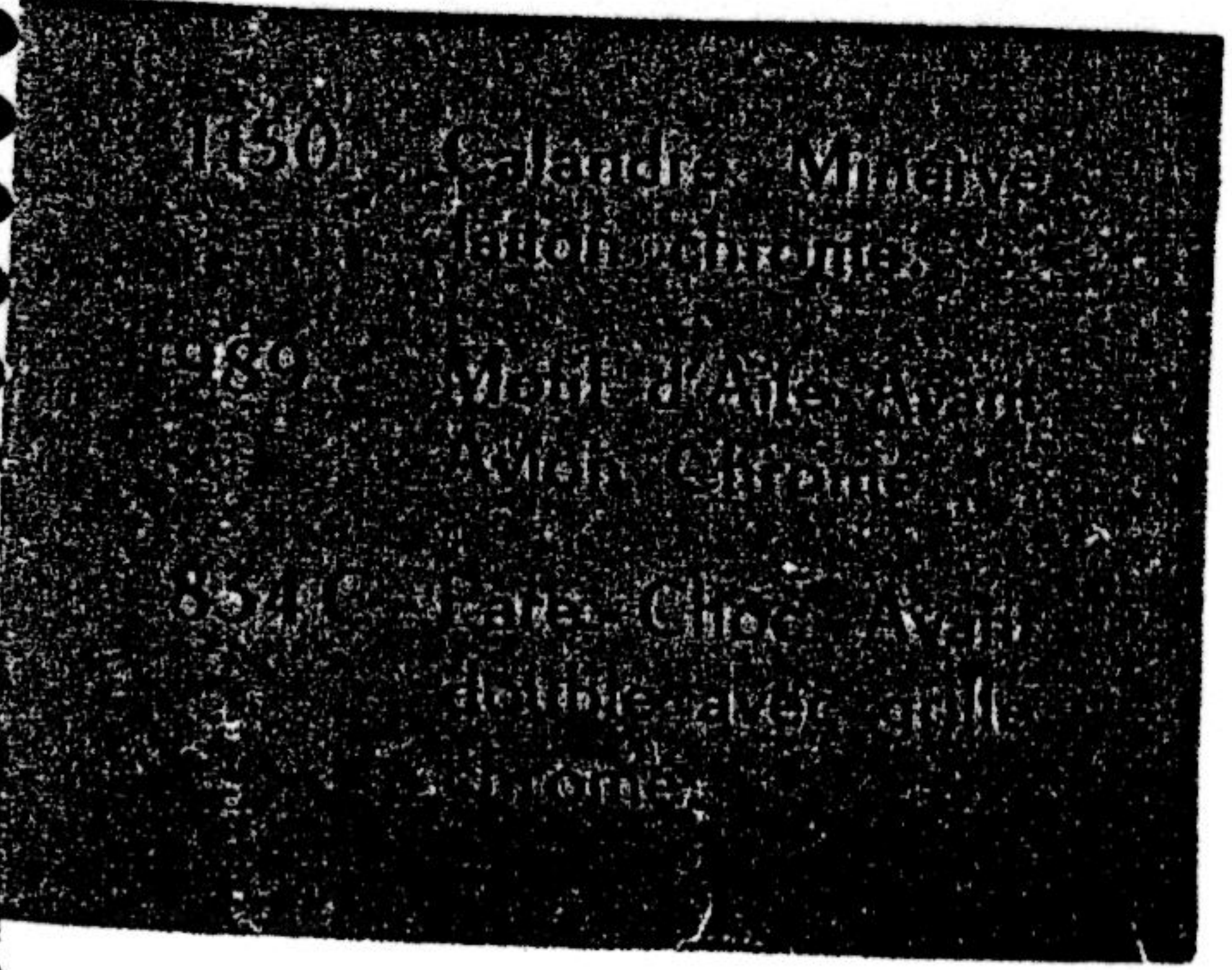

De la part de
FRAN DE SCOOTER

Porte-Bagages AR

1078 - Porte-Bagages AR Horizontal,
Poignée pliante à ressort, en-
tièrement chromé.

Système breveté.

Permet la pose d'un enjoliveur
de roue et d'un antivol de roue.

Se monte également sur 150 GL

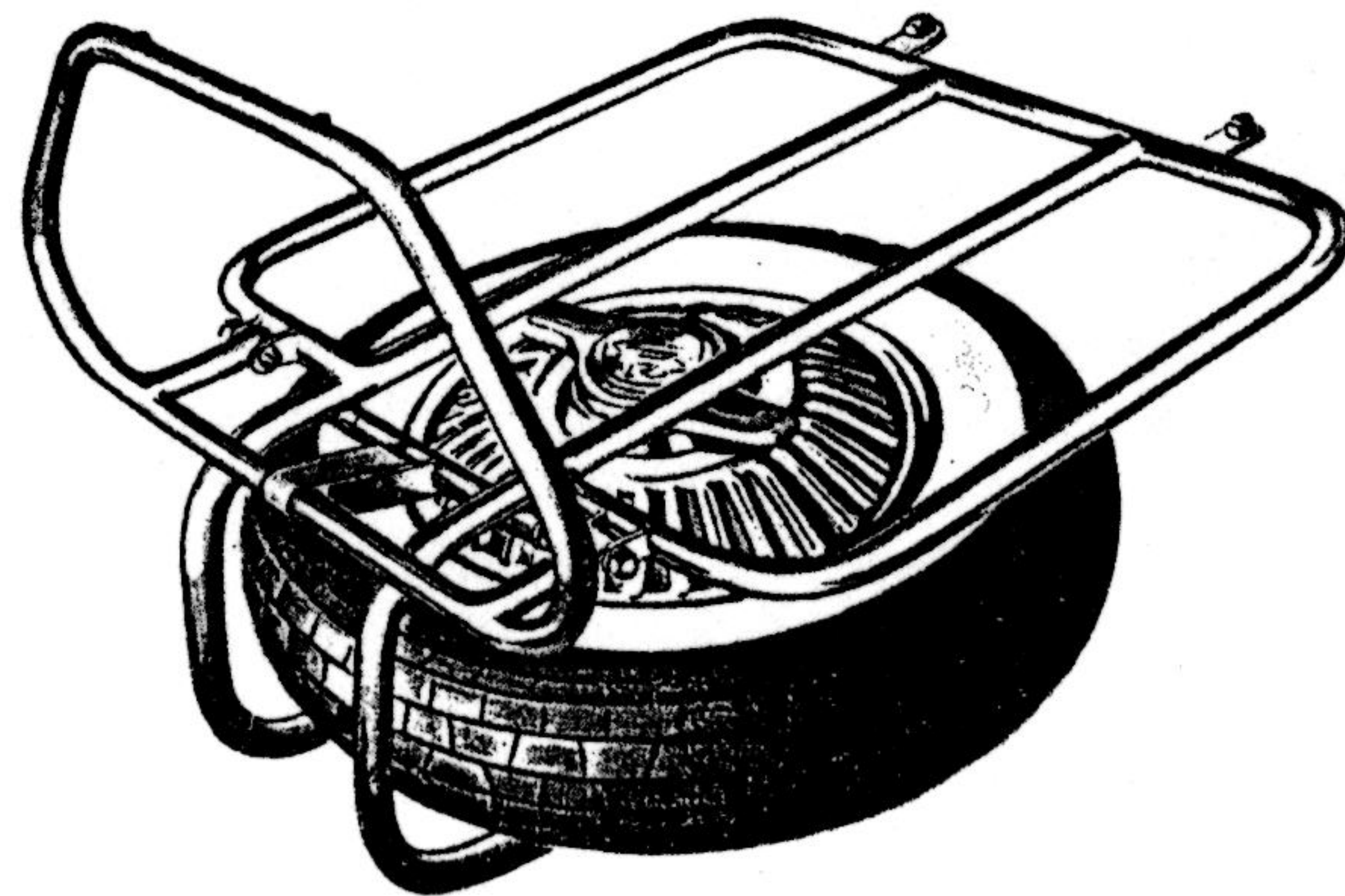
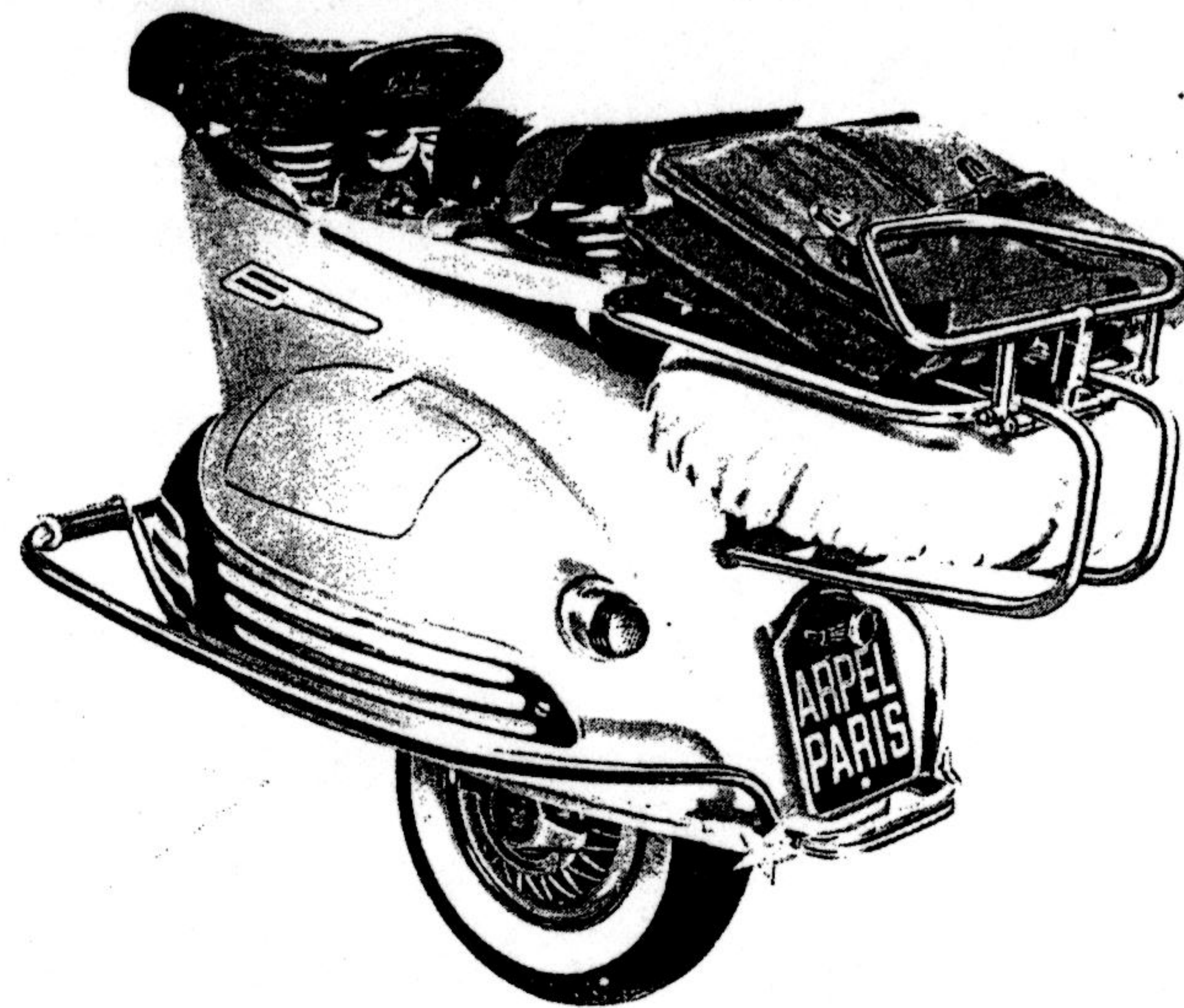
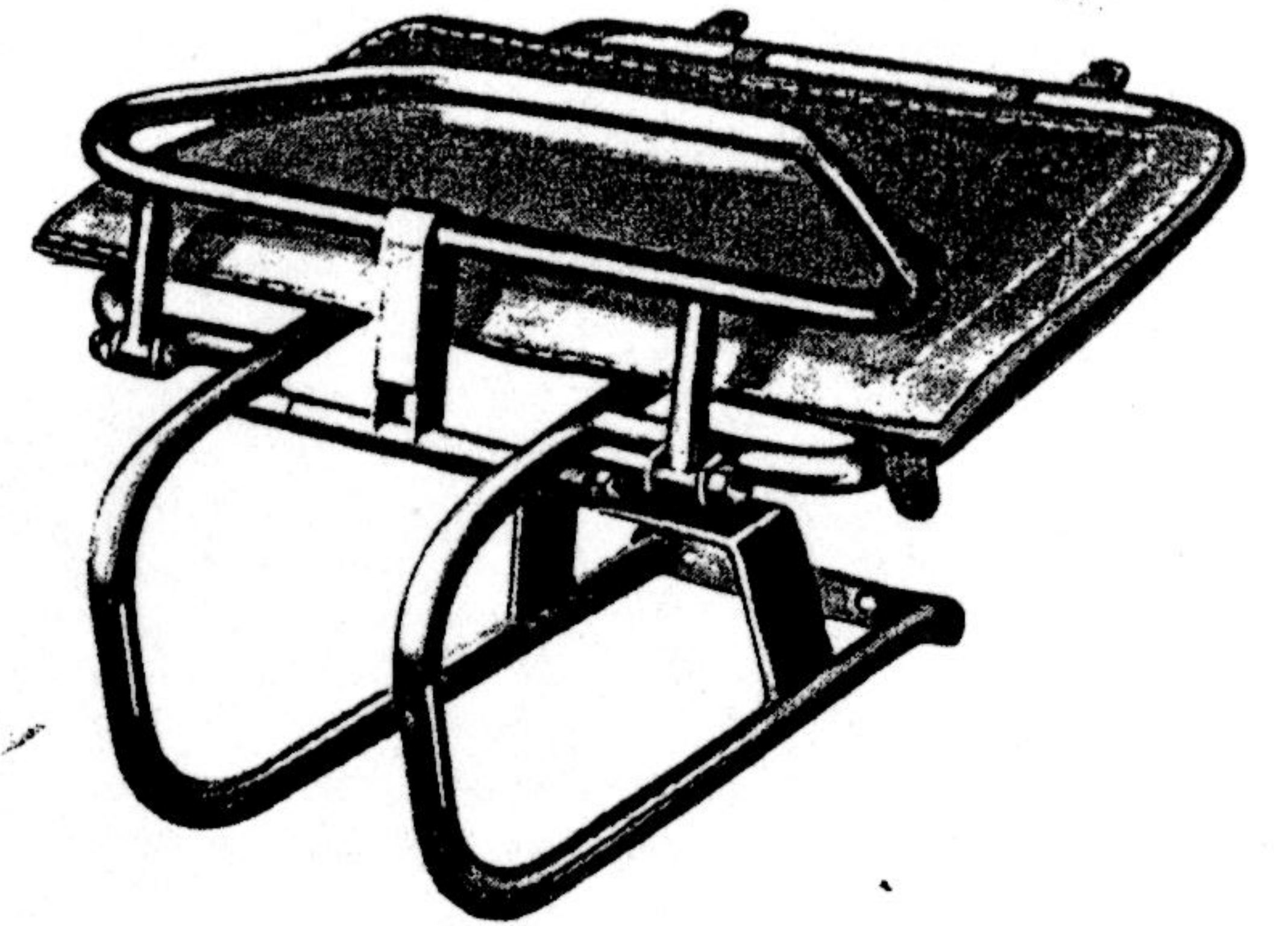
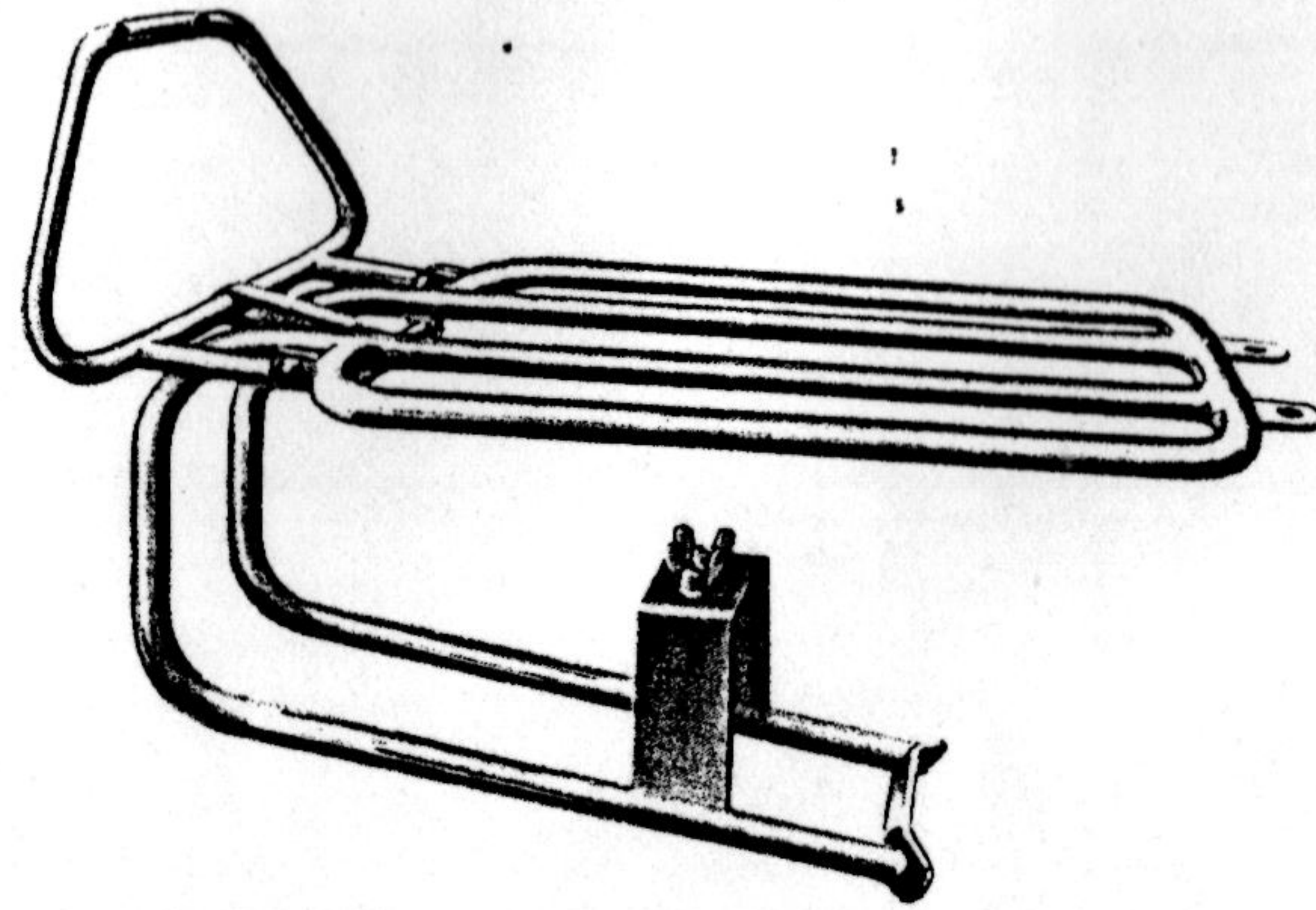

1073 - Porte-Bagages AR Horizontal,
Poignée fixe, entièrement chro-
mé, même montage que le 1078

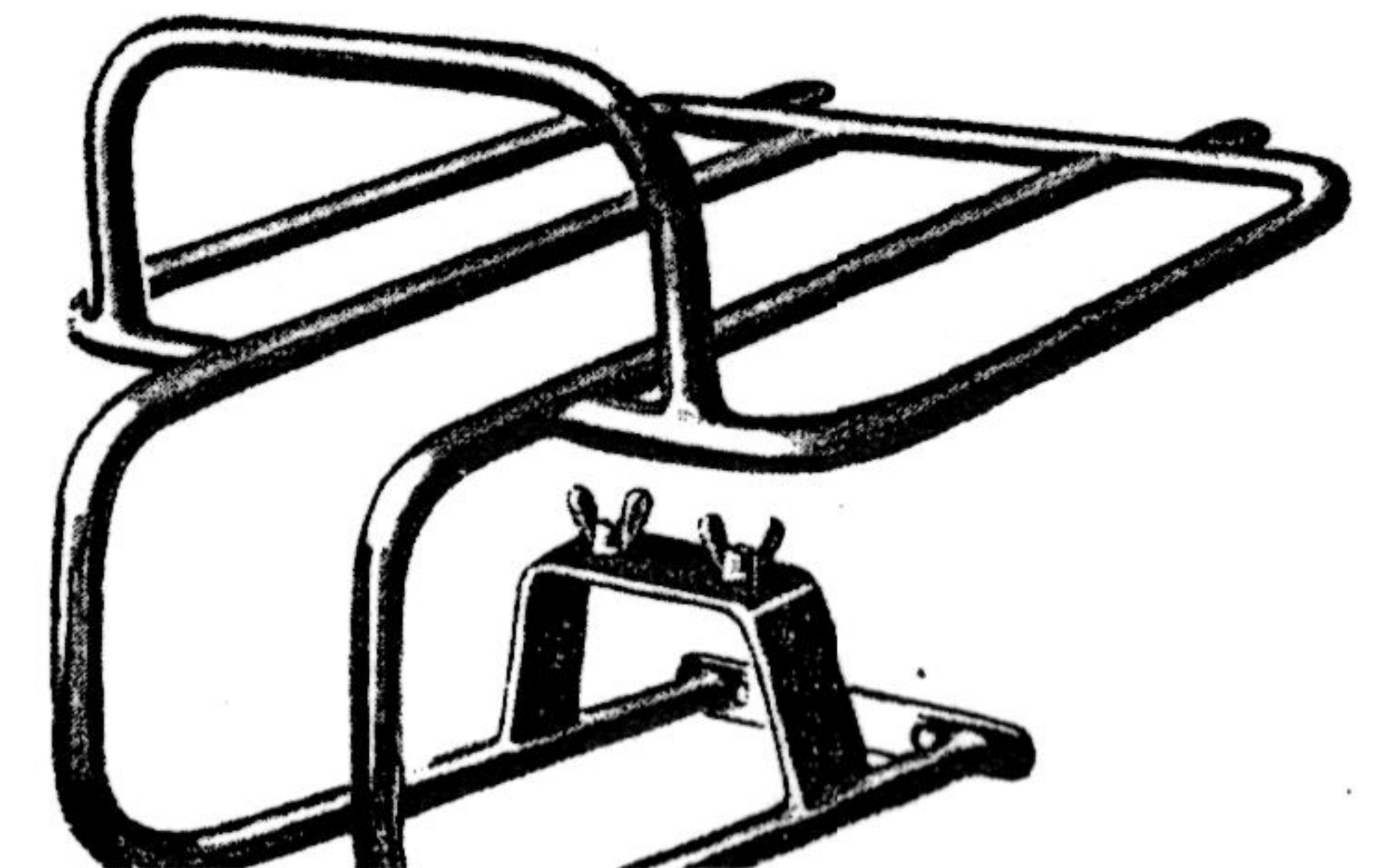

De la partie de
FAN DE SCOOTER

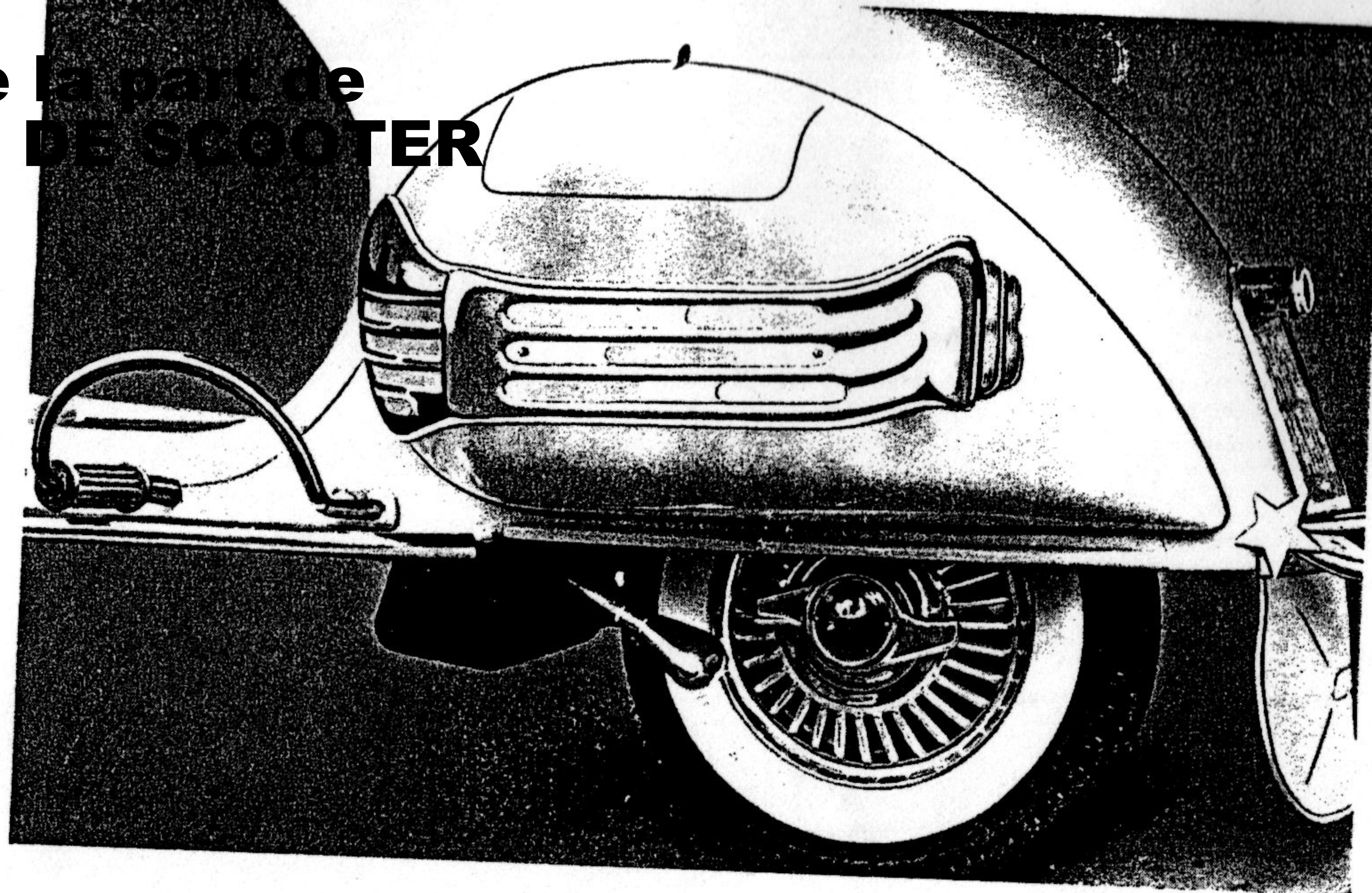

AA

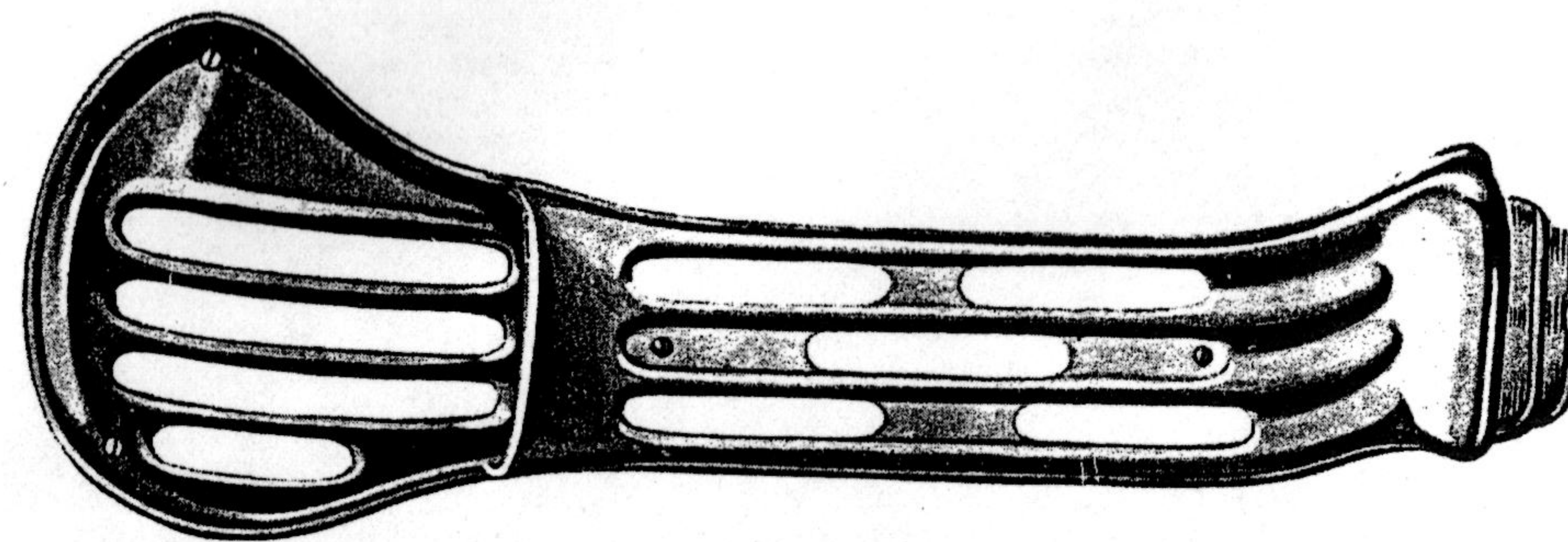

969 - Sabots d'Ailes, Grand Luxe, formant Aérateur
avec Stop et Clignotant. Laiton chromé.
Pour 150 GL et 125 cc.

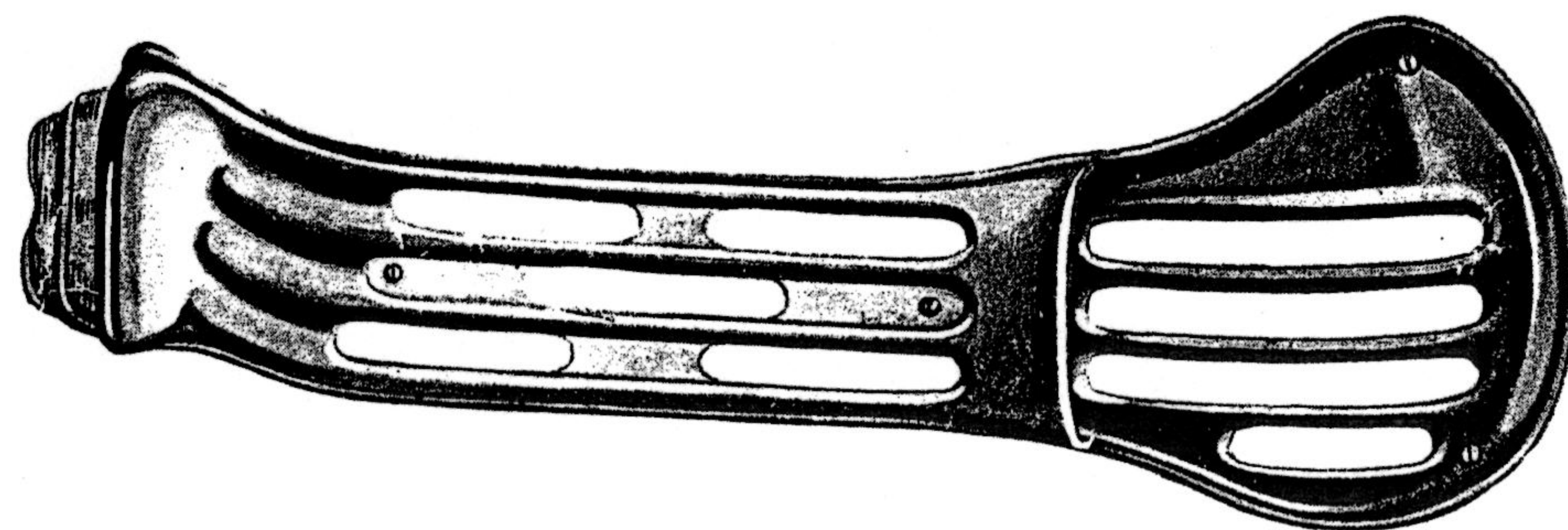
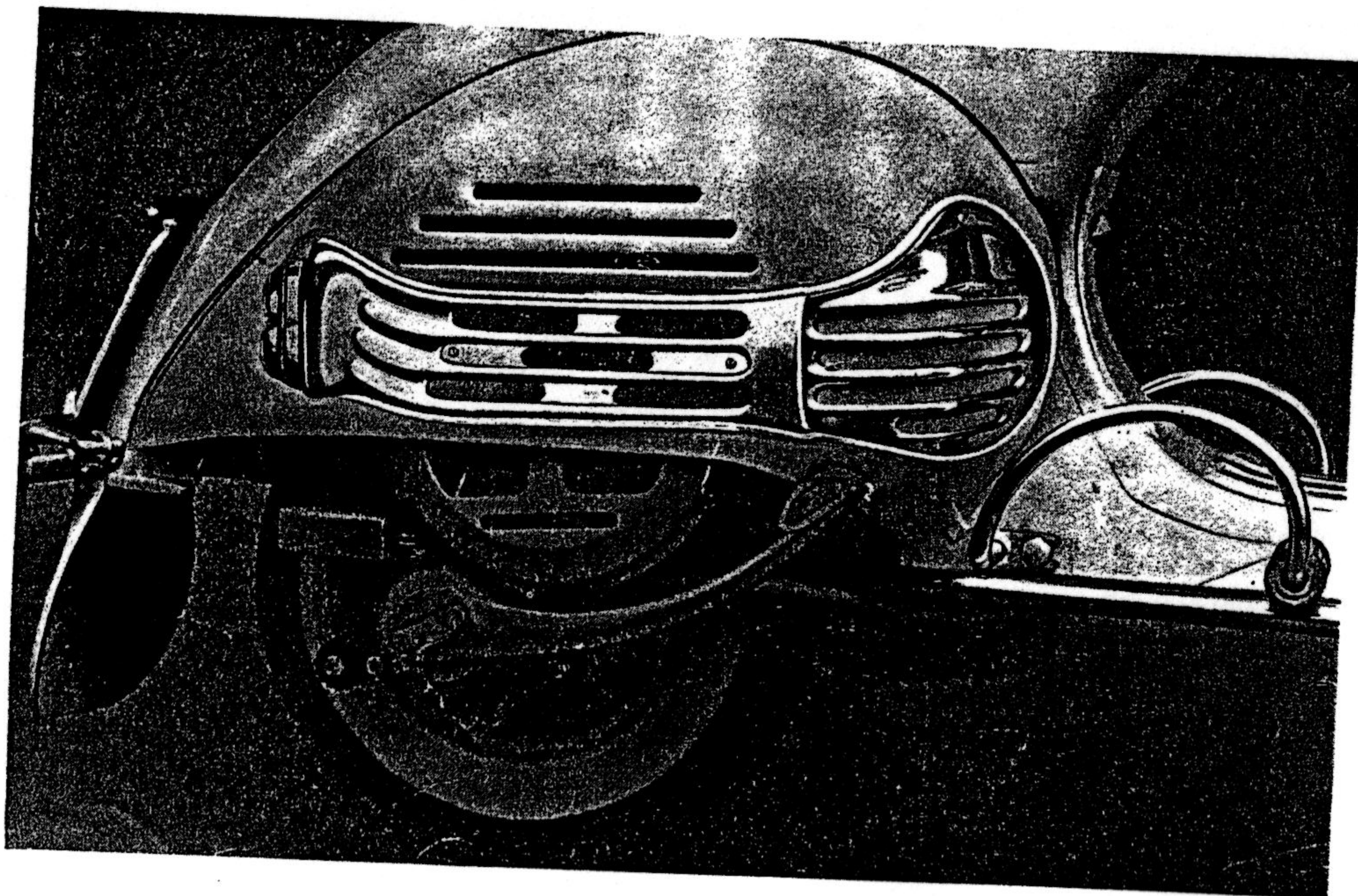

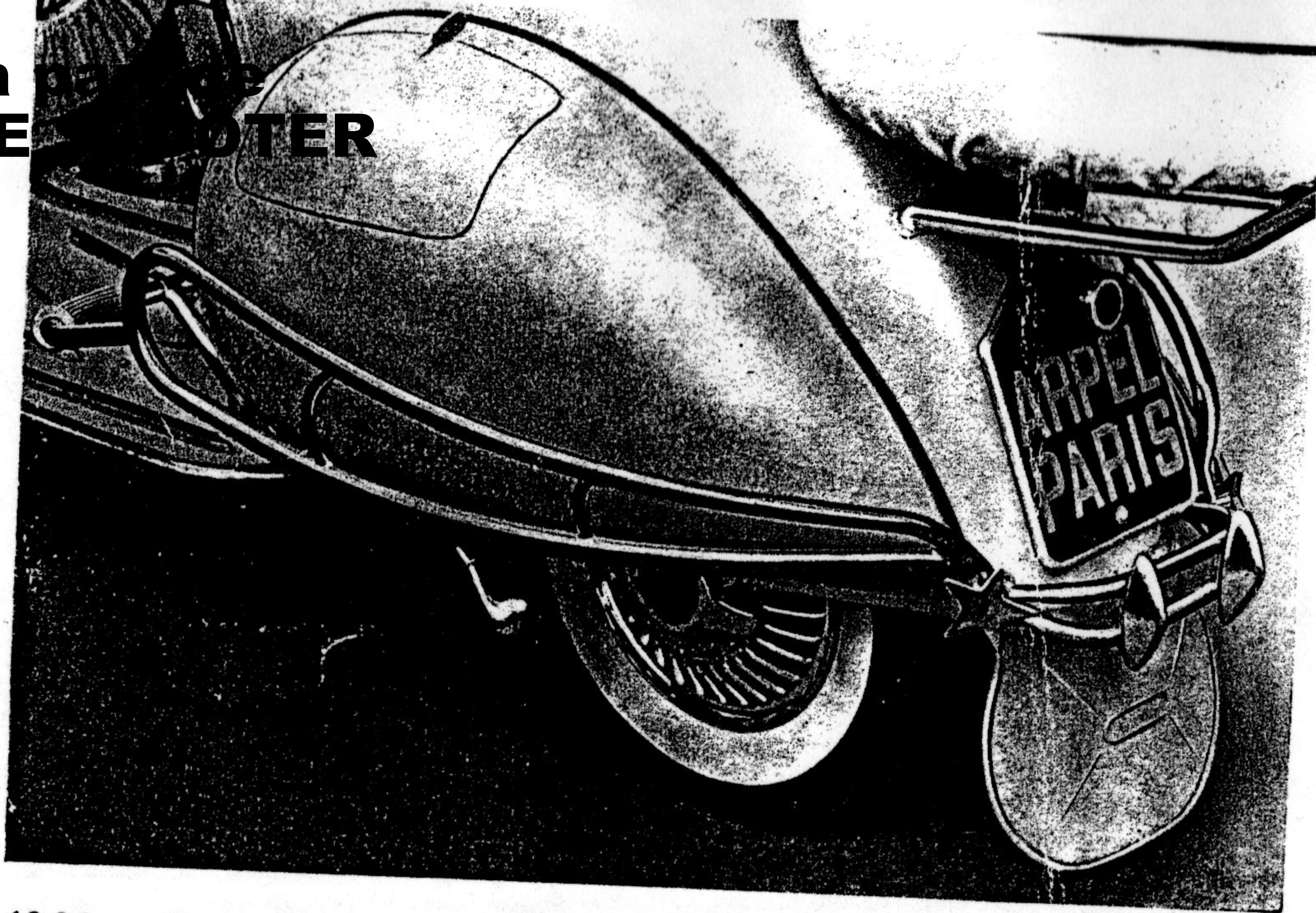

1066 - Pare-Chocs - Repose-Pieds latéraux double. Entièrement chromé. Pour 150 GL et 125 cc.



1166 - Pare-Chocs Latéraux Grand Luxe double avec Pare-Chocs Arrière double et Stop, équerre transversale renforcée.

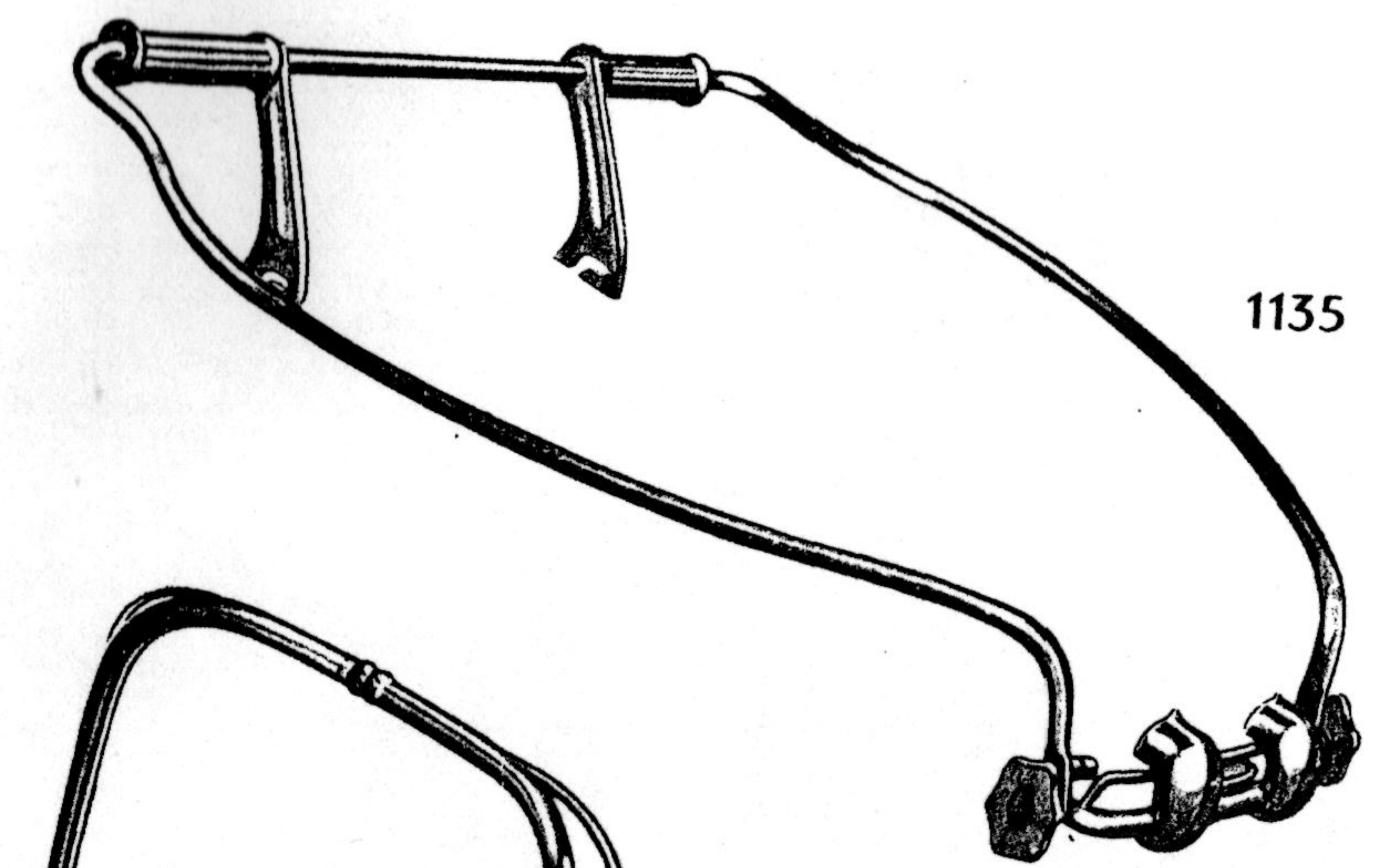

1135

1135 - Pare - Chocs Latéraux Grand Luxe avec Pare-Chocs Arrière double et Stop, équerre transversale renforcée.

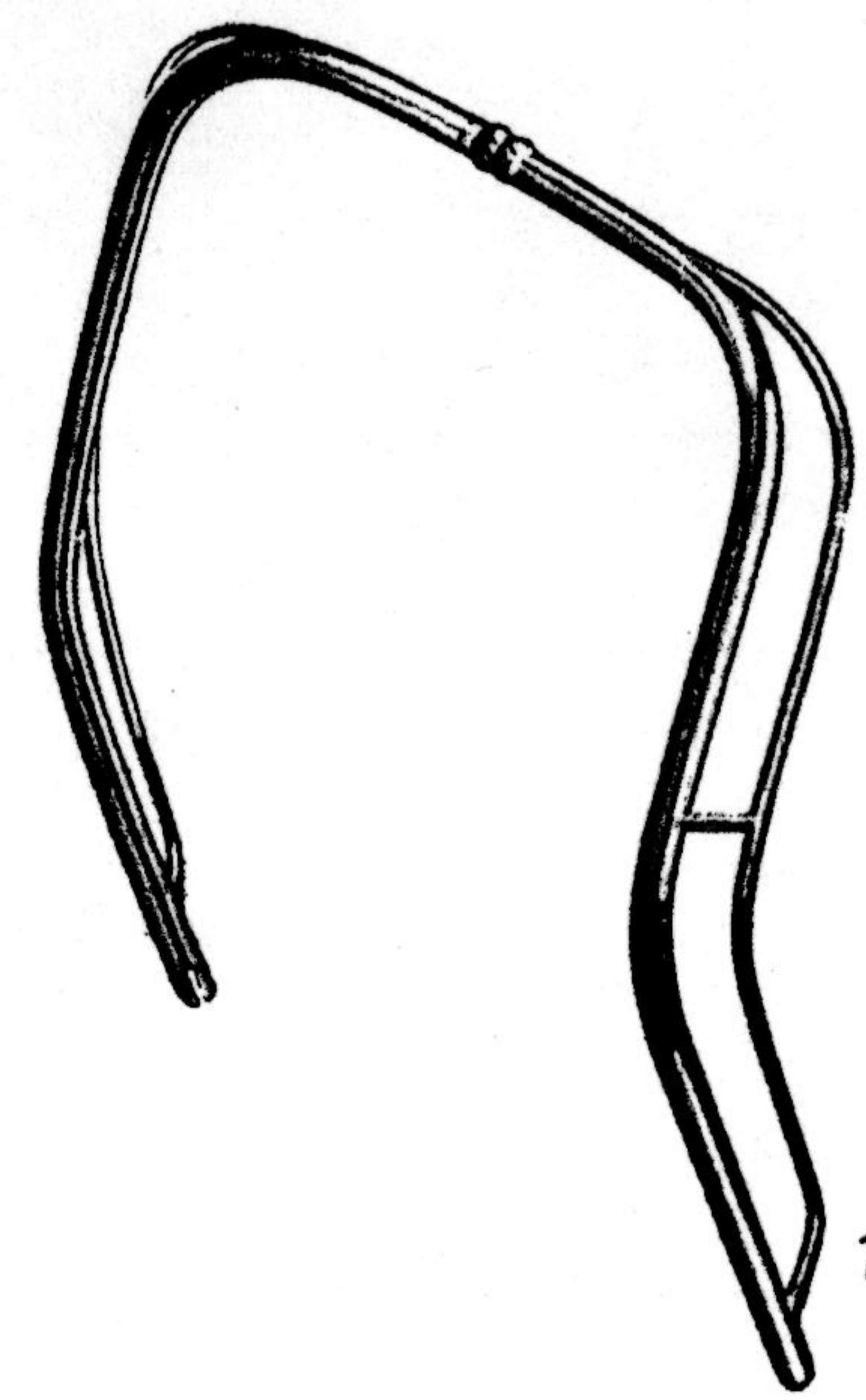

1071 - Enjoliveur protecteur de tablier double.

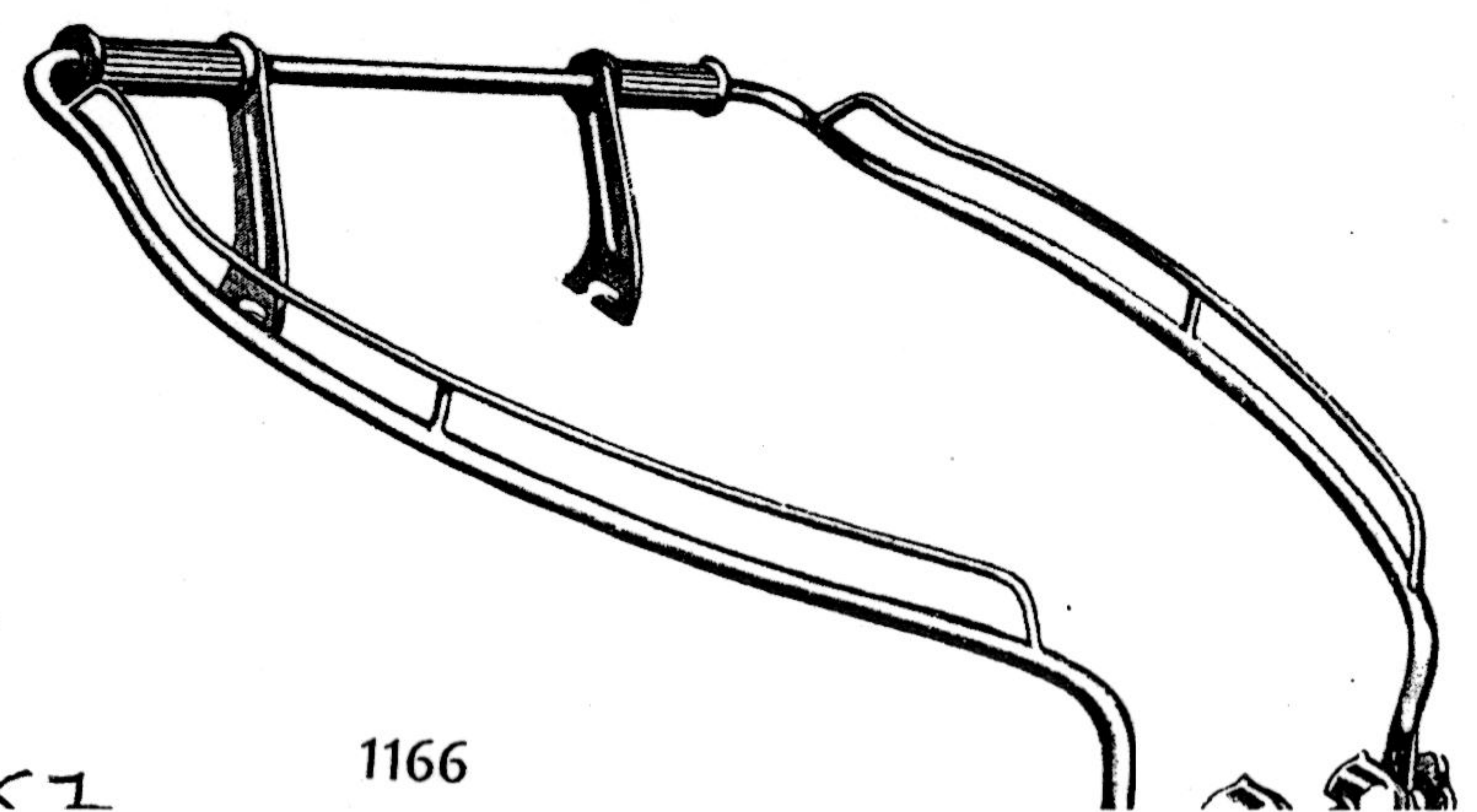

1166